

GMAX™ 3400, GMAX™ II 3900/5900/7900, and TexSpray 5900HD/7900HD Airless Sprayers

332921K
EN

For professional use only.
Not approved for use in European explosive atmosphere locations.
For the application of architectural paints and coatings.

3300 psi (22.8 MPa, 228 bar) Maximum Working Pressure



Important Safety Instructions
 Read all warnings and instructions in this manual.
 Save these instructions.

GMAX 3400					
Model:	Standard				
16W863	✓				
GMAX II 3900					
Model:	Standard	ProContractor	Lo-Boy	RentalPro 360G	
16W865	✓				
16W866			✓		
16W867		✓			
16W984				✓	
GMAX II 5900					
Model:	Standard	ProContractor	Lo-Boy	IronMan	Convertible
16W869	✓				
16W870			✓		
16W871		✓			
16W881				✓	
16W873					✓
GMAX II 7900					
Model:	Standard	ProContractor	Lo-Boy	IronMan	Roof Rig
16W883	✓				
16W884			✓		
16W885		✓			
16W987					✓
TexSpray 5900HD					
Model:	Standard	ProContractor			
16W889	✓				
16W882		✓			
TexSpray 7900HD					
Model:	Standard	ProContractor	IronMan		
16W890	✓				
16W888		✓			
16X949			✓		

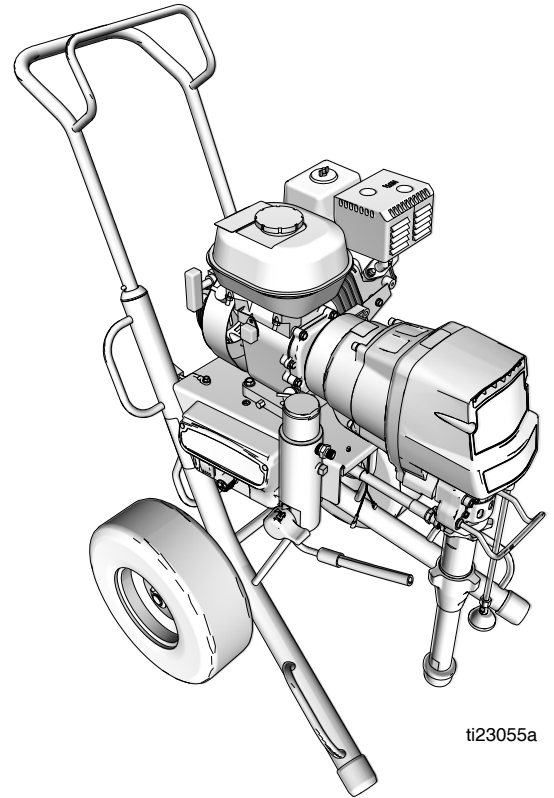

ti23055a

Related Manual:
 Operation 332919

Contents

GMAX 3400 Standard Series	4	GMAX II 7900/TexSpray 7900HD Standard Series/Roof Rig	27
Parts List - GMAX 3400 Standard Series	5	Parts List - GMAX II 7900/TexSpray 7900HD Standard Series/Roof Rig	28
GMAX II 3900 Standard Series/Rental Pro 360G ..	6	GMAX II 7900/TexSpray 7900HD ProContractor Series	29
Parts List - GMAX II 3900 Standard Series/Rental Pro 360G	7	Parts List - GMAX II 7900/TexSpray 7900HD ProContractor Series	30
GMAX II 3900 Lo-Boy Series	8	GMAX II 7900/TexSpray 7900 IronMan	32
Parts List - GMAX II 3900 Lo-Boy Series	9	Parts List - GMAX II 7900/TexSpray 7900HD IronMan	33
GMAX II 3900 ProContractor Series	10	GMAX II 7900 Lo-Boy	34
Parts List - GMAX II 3900 ProContractor Series ..	11	Parts List - GMAX II 7900/Lo-Boy	35
GMAX II 5900/5900HD Standard Series	12	LoBoy Suction Set Kits (Kits include suction set and drain hose) ...	37
Parts List - GMAX II 5900/5900HD Standard Series ..	13	Control Box 16X821	38
GMAX II 5900 Lo-Boy Series	14	Parts List - Control Box 16X821	39
Parts List - GMAX II 5900 Lo-Boy Series	15	Control Box 16X822	40
GMAX II 5900/5900HD ProContractor Series ...	16	Parts List - Control Box 16X822	41
Parts List - GMAX II 5900/5900HD ProContractor Series	17	Control Box 25P549	42
GMAX II 5900 IronMan Series	19	Parts List - Control Box 25P549	42
Parts List - GMAX II 5900 IronMan Series	20	Filter	43
GMAX II 5900 Convertible Series	21	Parts List - Filter	43
Parts List - GMAX II 5900 Convertible Series ..	22	Filter (3400 Models only)	44
GMAX II 5900 Convertible Series	23	Parts List - Filter	44
Engine Detail	23	Hose Reel (ProContractor Sprayers)	45
GMAX II 5900 Convertible Series	24	Pressure Control Wiring Diagrams	46
Engine Detail - Parts List	24	GMAX 3400 Sprayers	46
GMAX II 5900 Convertible Series	25	3900/5900/7900 Sprayers	47
Clutch Housing - Parts Drawing and List	25	Graco Standard Warranty	48

GMAX 3400 Standard Series

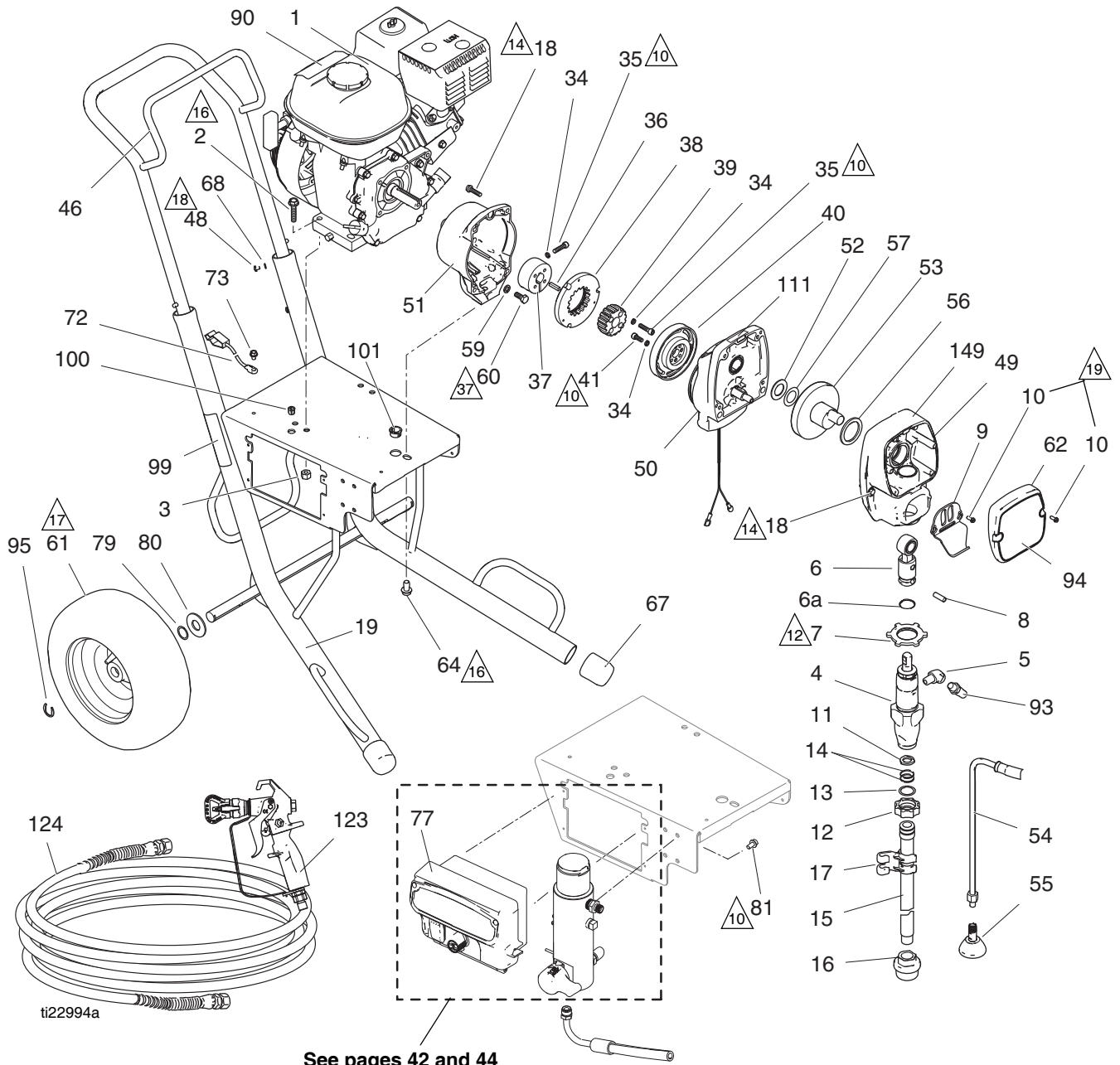

Parts List - GMAX 3400 Standard Series

Ref.	Part	Description	Qty.	Ref.	Part	Description	Qty.
1	108879	ENGINE, gasoline, 4.0 HP	1	60	108842	SCREW, cap, hex hd	4
	25P294	ENGINE, gasoline, 4.0 HP (China only)	1	61	119420	WHEEL, pneumatic	2
2	110837	SCREW, flange, hex	2	62	287487	COVER, front, painted, <i>includes 10</i>	1
3	110838	NUT, lock	2	64	112395	SCREW, cap, flng hd	1
4	246428	PUMP, displacement, st	1	67	15C871	CAP, leg	2
5	119789	FITTING, elbow, street, 45°, 1/4 npt	1	68	100020	WASHER, lock	4
6	287053	ROD, connecting	1	72	237686	WIRE, ground assembly w/clamp	1
6a	196750	SPRING, retaining	1	73	112798	SCREW, thread forming, hex hd	1
7	195150	NUT, jam, pump	1	77	25P549	BOX, control, GMAX 3400	1
8	196762	PIN, straight	1	79	116038	WASHER, wave spring	2
9	15C146	HOOK, pail	1	80	156306	WASHER, flat	2
10	117501	SCREW, mach, hex washer hd	4	81	113161	SCREW, flange, hex hd	3
11	115099	WASHER, garden hose	1	90▲	194126	LABEL, warning	1
12	15E813	NUT, jam	1	93	241926	HOSE, coupled	1
13	15B652	WASHER, suction	1	94	16X353	LABEL, brand	1
14	103413	O-RING	2	95	15E891	CLIP, retaining	2
15	15E805	TUBE, intake, 3400	1	99▲	15F638	LABEL, warning	1
16	246385	STRAINER, 7/8-14 unf	1	100	114678	BUSHING, strain relief	1
17	276888	CLIP, drain line	1	101	119569	BUSHING, strain relief	1
18	119426	SCREW, mach, hex washer hd	8	111▲	290228	LABEL, caution	1
19	287411	FRAME, cart, GMAX 3400 hi	1	123	288420	GUN, contractor, RAC X, packaged	1
34	105510*	WASHER, lock, spring (hi-collar)	10	124	240794	HOSE, coupled, 1/4 in. x 50 ft	1
35	108803	SCREW, hex, socket head	6	135	15F354	FUNNEL, oil (not shown)	1
36	183401	KEY, parallel	1	149	16X983	LABEL, brand, standard	1
37	193680	COLLAR, shaft	1	▲	16Y631	LABEL, warning	1
38	*	ARMATURE, clutch, 4 in.	1	▲	16Y632	LABEL, warning	1
39	*	HUB, armature	1	▲	16Y633	LABEL, warning	1
40	*	ROTOR, clutch, 4 in.	1				
41	101682*	SCREW, cap, sch	4				
46	287489	HANDLE, cart	1				
48	109032	SCREW, mach, pnh	4				
49	287483	HOUSING, drive, 3400 <i>includes 9, 10, 18 & grease 110293</i>	1				
50	287376	HOUSING, pinion, 3400	1				
51	15E535	HOUSING, clutch, mach, 3400	1				
52	116074	WASHER, thrust	1				
53	287484	CRANK, GMAX 3400 <i>includes 52, 56, 57</i>	1				
54	244240	HOSE, coupled, <i>includes 55</i>	1				
55	241920	DEFLECTOR, threaded	1				
56	180131	BEARING, thrust	1				
57	107434	BEARING, thrust	1				
59	100214	WASHER, lock	4				

▲ Replacement Danger and Warning Labels, Tags and Cards are available at no cost.

* Included in Clutch Replacement Kit 241109.

Part Specifications:

Ref.	Instruction
▲10	Torque to 115-135 in-lb (12.9-15.2 N•m)
▲12	Torque to 70-80 ft-lb (94.9-108.4 N•m)
▲14	Torque to 130-150 in-lb (14.6-16.9 N•m)
▲16	Torque to 17-23 ft-lb (23.0-31.1 N•m)
▲17	Inflate tires to 28-32 psi (1.93-2.21 bar/0.193-0.221 MPa)
▲18	Torque to 25-35 in-lb (2.8-3.9 N•m)
▲19	Torque to 30-35 in-lb (3.3-3.9 N•m)
▲37	Torque to 170-190 in-lb (19.2-21.4 N•m)

GMAX II 3900 Standard Series/Rental Pro 360G

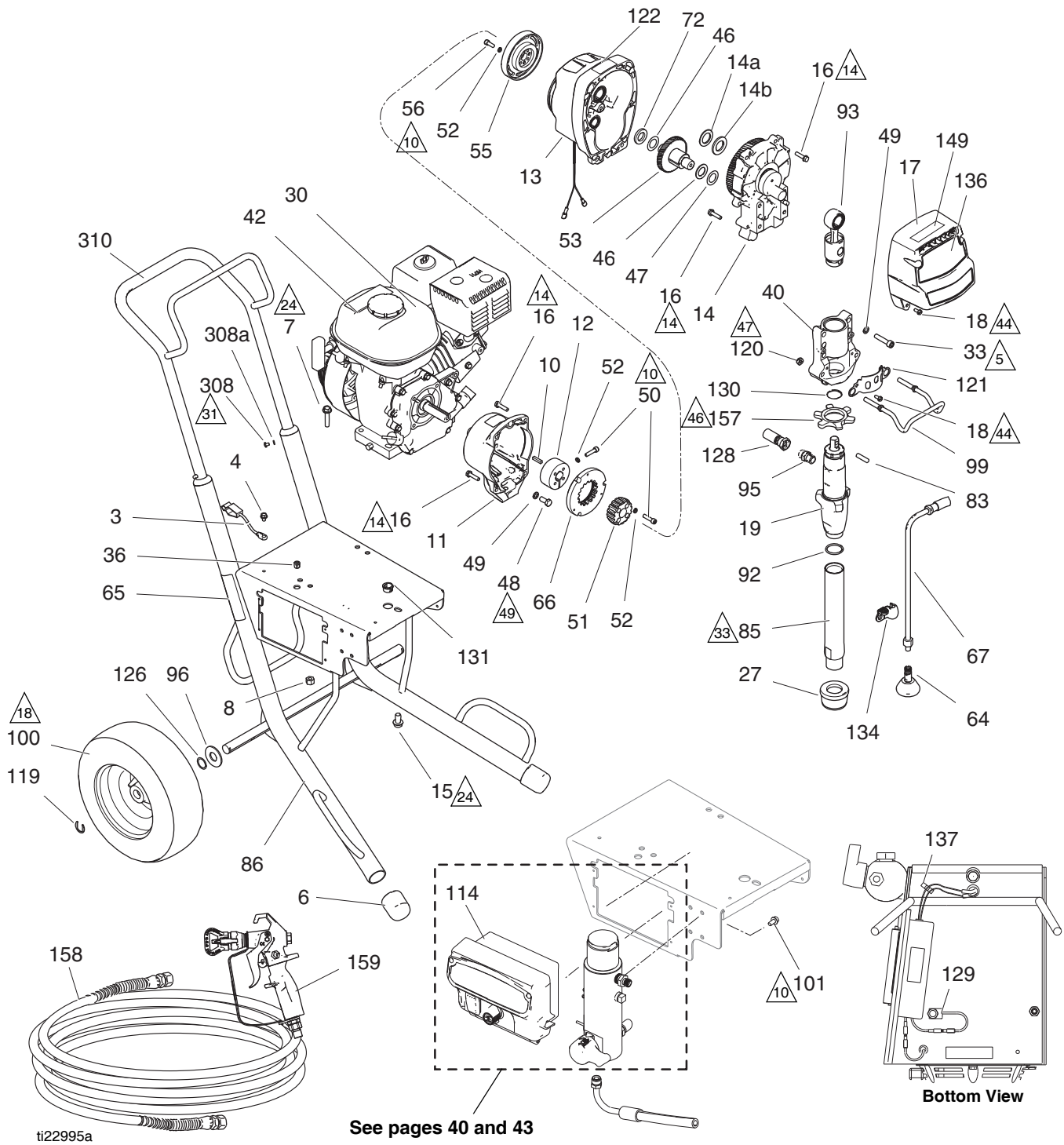

Parts List - GMAX II 3900 Standard Series/Rental Pro 360G

Ref.	Part	Description	Qty.	Ref.	Part	Description	Qty.
3	237686	WIRE, ground assembly w/ clamp	1	119	15E891	CLIP, retaining	2
4	112798	SCREW, thread forming, hex hd	1	120★	111040	NUT, lock, insert, nylon	2
6	15C871	CAP, leg	2	121★	16X770	SHIELD, pump rod	1
7	110837	SCREW, flange, hex	2	122▲	290228	LABEL, caution	1
8	110838	NUT, lock	2	126	116038	WASHER, wave spring	2
10	183401	KEY, parallel	1	128	16X909	HOSE, coupled	1
11	15E535	HOUSING, clutch, machine	1	129	119579	CONDUCTOR, ground	1
12	193680	COLLAR, shaft	1	130	119676	SPRING, retaining	1
13	287463	HOUSING, pinion, 3900	1	131	119569	BUSHING, strain relief	1
14	287467	HOUSING, drive, 3900, <i>includes 14a, 14b</i>	1	134★	278204	CLIP, drain line	1
14a	116191	WASHER, thrust	1	135	15F354	FUNNEL, oil (not shown)	1
14b	107089	WASHER, race, thrust	1	136	16X348	LABEL, front, 3900	1
15	112395	SCREW, cap, flng hd	1		16X359	LABEL, front, 360G	1
16	119426	SCREW, mach, hex washer hd	10	137	114687	CLIP, retainer	1
17	16Y747	COVER, front, (includes 18)	1	149	16X983	LABEL, standard series	1
18★	118444	SCREW, mach, slot hex wash hd	6	157	192723	NUT, retaining	1
19	16Y598	PUMP, displacement, <i>includes 85, 92, 95</i>	1	158	240794	HOSE, coupled, 1/4 in. x 50 ft	1
27	189920	STRAINER, (1-11 1/2 NPSM)	1	159	288420	GUN, contractor, RAC X, packaged	1
30	108879	ENGINE, gasoline, 4.0 HP	1	308	109032	SCREW, mach, pnh	4
33	113467	SCREW, cap, socket hd	4	308a	100020	WASHER, lock	4
36	114678	BUSHING, strain relief	1	310	287489	HANDLE, cart	1
40★		HOUSING, bearing	1	▲	16Y631	LABEL, warning	1
42▲	194126	LABEL, warning	1	▲	16Y632	LABEL, warning	1
46	114699	WASHER, thrust	2	▲	16Y633	LABEL, warning	1
47	114672	WASHER, thrust	1				
48	108842	SCREW, cap, hex hd	4				
49★	100214	WASHER, lock	8				
50†	108803	SCREW, hex, socket head	6				
51†		HUB, armature	1				
52†	105510	WASHER, lock, spring (hi-collar)	10				
53	287653	GEAR, combination	1				
55†		ROTOR, clutch, 4 in.	1				
56†	101682	SCREW, cap, sch	4				
64	241920	DEFLECTOR, threaded	1				
65▲	15F638	LABEL, warning fire and skin, GMAX	1				
66†		ARMATURE, clutch, 4 in.	1				
67	244240	HOSE, coupled, <i>includes 64</i>	1				
72	15F250	WASHER, thrust	1				
83	15F855	PIN, pump	1				
85	15E807	TUBE, intake	1				
86	287411	FRAME, standard, cart	1				
92	118494	PACKING, o-ring	1				
93	241008	ROD, connecting	1				
95	196178	FITTING	1				
96	156306	WASHER, flat	2				
99★	16C457	HANGER, pail	1				
100	119420	WHEEL, pneumatic	2				
101	113161	SCREW, flange, hex hd	3				
114	16X822	BOX, control	1				

▲ Replacement Danger and Warning Labels, Tags and Cards are available at no cost.

† Included in Clutch Replacement Kit 241109.

★ Included in bearing housing kit 24V026

Part Specifications:

Ref.	Instruction
5	Torque to 190-210 in-lb (21.4-23.7 N•m)
10	Torque to 115-135 in-lb (12.9-15.2 N•m)
14	Torque to 130-150 in-lb (14.6-16.9 N•m)
18	Inflate tires to 28-32 psi (1.93-2.21 bar/0.193-0.221 MPa)
24	Torque to 17-23 ft-lb (23.0-31.1 N•m)
31	Torque to 25-35 in-lb (2.8-3.9 N•m)
33	Torque to 70-90 in-lb (7.9-10.1 N•m)
44	Torque to 30-35 in-lb (3.3-3.9 N•m)
46	Torque to 70-80 ft-lb (94.9-108.4 N•m)
47	Torque to 200-230 in-lb (22.5-25.9 N•m)
49	Torque to 170-190 in-lb (19.2-21.4 N•m)

Parts List - GMAX II 3900 Lo-Boy Series

Ref.	Part	Description	Qty.	Ref.	Part	Description	Qty.
3	237686	WIRE, ground assembly w/ clamp	1	112	16Y780	HANDLE, cart	1
4	112798	SCREW, thread forming, hex hd	1	114	16X822	BOX, control	1
6	276974	CAP, leg	2	119	15E891	CLIP, retaining	2
7	110837	SCREW, flange, hex	2	122▲	290228	LABEL, caution	1
8	110838	NUT, lock	2	126	116038	WASHER, wave spring	2
10	183401	KEY, parallel	1	128	16X950	HOSE, coupled	1
11	15E535	HOUSING, clutch, machine	1	129	119579	CONDUCTOR, ground	1
12	193680	COLLAR, shaft	1	130	122533	FITTING, 45 deg	1
13	287463	HOUSING, pinion, 3900	1	131	119569	BUSHING, strain relief	1
14	287467	HOUSING, drive, 3900, <i>includes 14a, 14b</i>	1	136	16X348	LABEL, front, GMAX II 3900	1
14a	116191	WASHER, thrust	1	137	114687	CLIP, retainer	1
14b	107089	WASHER, race, thrust	1	149	16X979	LABEL, ProConnect	1
15	112395	SCREW, cap, flng hd	1	158	288420	GUN, contractor, RAC X, packaged	1
16	119426	SCREW, mach, hex washer hd	10	171★	16X228	PLATE, front, 3900, PC II	1
17	16Y747	COVER, front, 3900 (includes 18)	1	172★	16X322	CLAMP, pump, small	1
18★	118444	SCREW, mach, slot hex wash hd	4	173★	101550	SCREW, cap, sch	2
19	16X414	PUMP, displacement 3900, <i>includes 85, 92, 95</i>	1	174★	16C457	HANGER, pail	1
24★	100214	WASHER, lock, spring	4	175★	111040	NUT, lock, insert, nylock, 5/16	2
30	108879	ENGINE, gasoline, 4.0 HP	1	176	120583	NUT, hand	1
	25P294	ENGINE, gasoline, 4.0 HP (China only)	1	177	16X833	FITTING, quick disconnect, 3/8 npsm	1
33	113467	SCREW, cap, socket hd	4	▲	16Y631	LABEL, warning	1
36	114678	BUSHING, strain relief	1	▲	16Y632	LABEL, warning	1
39	107505	PACKING, o-ring	1	▲	16Y633	LABEL, warning	1
40★		HOUSING, bearing 3900	1	▲ <i>Replacement Danger and Warning Labels, Tags and Cards are available at no cost.</i>			
42▲	194126	LABEL, warning	1	† <i>Included in Clutch Replacement Kit 241109.</i>			
46	114699	WASHER, thrust	2	★ <i>Included in bearing housing kit 24V087</i>			
47	114672	WASHER, thrust	1	Part Specifications:			
48	108842	SCREW, cap, hex hd	4				
49	100214	WASHER, lock	4				
50†	108803	SCREW, hex, socket head	6				
51†		HUB, armature	1				
52†★	105510	WASHER, lock, spring (hi-collar)	12				
53	287653	GEAR, combination 3900	1				
55†		ROTOR, clutch, 4 in.	1				
56†	101682	SCREW, cap, sch	4				
65▲	15F638	LABEL, GMAX warning fire and skin	1				
66†		ARMATURE, clutch, 4 in.	1				
71	240794	HOSE, coupled, 1/4 in. x 50 ft	1				
72	15F250	WASHER, thrust	1				
86	16Y519	FRAME	1				
93	24V084	ROD, connecting 3900	1				
95	16Y579	FITTING	1				
96	156306	WASHER, flat	2				
100	119509	WHEEL, pneumatic	2				
101	113161	SCREW, flange, hex hd	3				
110	109032	SCREW, mach, pnh	4				
111	100020	WASHER, lock, 3900 only	4				

Ref.	Instruction
▲21	Inflate tires to 28-32 psi (1.93-2.21 bar/0.193-0.221 MPa)
▲23	Torque clamp adjustment bolt to 90-110 in-lb (10.1-12.4 N•m) with reference 19 installed and ProConnect in locked position.
▲27	Torque to 17-23 ft-lb (23.0-31.1 N•m)
▲28	Torque to 190-210 in-lb (21.4-23.7 N•m)
▲29	Torque to 115-135 in-lb (12.9-15.2 N•m)
▲31	Torque to 130-150 in-lb (14.6-16.9 N•m)
▲32	Torque to 30-45 in-lb (3.3-5.0 N•m)
▲33	Torque to 90-110 in-lb (10.1-12.4 N•m)
▲40	Torque to 60-65 in-lb (6.7-7.3 N•m)
▲42	Torque to 170-190 in-lb (19.2-21.4 N•m)
▲43	Torque to 200-230 in-lb (22.5-25.9 N•m)
▲44	Torque to 25-35 in-lb (2.8-3.9 N•m)

GMAX II 3900 ProContractor Series

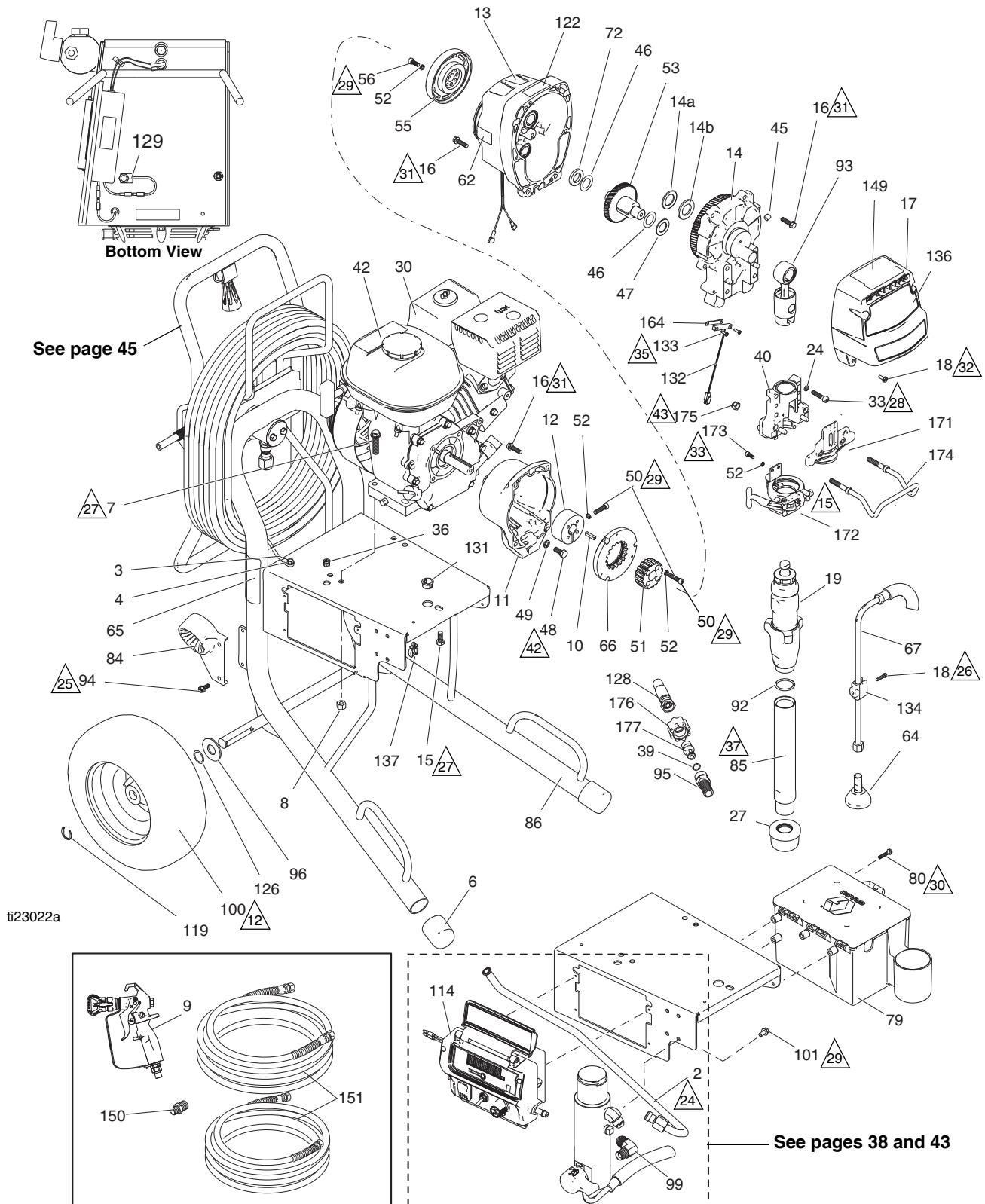

Parts List - GMAX II 3900 ProContractor Series

Ref.	Part	Description	Qty.	Ref.	Part	Description	Qty.
2	16C384	TUBE, 3900	1	128	16X904	HOSE, coupled	1
3	237686	WIRE, ground assembly w/ clamp	1	129	119579	CONDUCTOR, ground	1
4	112798	SCREW, thread forming, hex hd	1	131	119569	BUSHING, strain relief	1
6	15C871	CAP, leg	2	132	119562	SWITCH, reed w/connector	1
7	110837	SCREW, flange, hex	2	133	114528	SCREW, mach, phillips, pnhd	2
8	110838	NUT, lock	2	134	16X203	CLIP, drain line	1
9	288420	GUN, contractor, RAC X, packaged	1	135	15F354	FUNNEL, oil (not shown)	1
10	183401	KEY, parallel	1	136	16X348	LABEL, front, GMAX II 3900	1
11	15E535	HOUSING, clutch, machine	1	137	114687	CLIP, retainer	1
12	193680	COLLAR, shaft	1	149	16X981	LABEL, Proconnect	1
13	287463	HOUSING, pinion, 3900	1	150	162453	NIPPLE, 1/4 npsm x 1/4 npt	1
14	287467	HOUSING, drive, 3900, <i>includes 14a, 14b</i>	1	151	240794	HOSE, coupled, 1/4 in x 50 ft	2
14a	116191	WASHER, thrust	1	164	15F947	SHIELD, magnetic	1
14b	107089	WASHER, race, thrust	1	171★	16X228	PLATE, front, 3900, PC II	1
15	112395	SCREW, cap, flng hd	1	172★	16X322	CLAMP, pump, small	1
16	119426	SCREW, mach, hex washer hd	10	173★	101550	SCREW, cap, sch	2
17	16Y747	COVER, front, 3900, <i>includes 18</i>	1	174★	16C457	HANGER, pail	1
18★	118444	SCREW, mach, slot hex wash hd	5	175★	111040	NUT, lock, insert, nylock, 5/16	2
19	16X414	PUMP, displacement 3900, <i>includes 85, 92, 95</i>	1	176	120583	NUT, hand	1
24★	100214	WASHER, lock, spring	4	177	16X833	FITTING, quick disconnect, 3/8 npsm	1
27	189920	STRAINER, (1-11 1/2 NPSM)	1	▲	16Y631	LABEL, warning	1
30	108879	ENGINE, gasoline, 4.0 HP	1	▲	16Y632	LABEL, warning	1
33	113467	SCREW, cap, socket hd	4	▲	16Y633	LABEL, warning	1
36	114678	BUSHING, strain relief	1				
39	107505	PACKING, o-ring	1				
40★		HOUSING, bearing 3900	1				
42▲	194126	LABEL, warning	1				
45	116618	MAGNET	1				
46	114699	WASHER, thrust	2				
47	114672	WASHER, thrust	1				
48	108842	SCREW, cap, hex hd	4				
49	100214	WASHER, lock	4				
50†	108803	SCREW, hex, socket head	6				
51†		HUB, armature	1				
52†★	105510	WASHER, lock, spring (hi-collar)	12				
53	287653	GEAR, combination 3900	1				
55†		ROTOR, clutch, 4 in.	1				
56†	101682	SCREW, cap, sch	4				
62		LABEL, USA made with Honda	1				
64	241920	DEFLECTOR, threaded	1				
65▲	15F638	LABEL, GMAX warning fire and skin	1				
66†		ARMATURE, clutch, 4 in.	1				
67	244240	HOSE, coupled, <i>includes 64</i>	1				
72	15F250	WASHER, thrust	1				
79	287253	TOOL BOX, <i>includes 94</i>	1				
80	118852	SCREW, thd forming, hex washer hd	3				
85	15E807	TUBE, intake	1				
84	278083	GUIDE, hose,	1				
86	24D045	FRAME, hose reel	1				
92	118494	PACKING, o-ring	1				
93	24V084	ROD, connecting 3900	1				
94	117633	SCREW, slot hex wash hd	2				
95	16Y579	FITTING	1				
96	156306	WASHER, flat	2				
99	125926	FITTING, 90 deg	1				
100	119420	WHEEL, pneumatic	2				
101	113161	SCREW, flange, hex hd	3				
114	16X821	BOX, control	1				
119	15E891	CLIP, retaining	2				
122▲	290228	LABEL, caution	1				
126	116038	WASHER, wave spring	2				

▲ Replacement Danger and Warning Labels, Tags and Cards are available at no cost.

† Included in Clutch Replacement Kit 241109.

★ Included in bearing housing kit 24V087

Part Specifications:

Ref.	Instruction
▲12	Inflate tires to 28-32 psi (1.93-2.21 bar/0.193-0.221 MPa)
▲15	Torque clamp adjustment bolt to 90-110 in-lb (10.1-12.4 N•m) with reference 19 installed and ProConnect in locked position.
▲24	Torque to 38-42 ft-lb (51.5-56.9 N•m)
▲25	Torque to 120-130 in-lb (13.5-14.6 N•m)
▲26	Torque to 40-45 in-lb (4.5-5.0 N•m)
▲27	Torque to 17-23 ft-lb (23.0-31.1 N•m)
▲28	Torque to 190-210 in-lb (21.4-23.7 N•m)
▲29	Torque to 115-135 in-lb (12.9-15.2 N•m)
▲30	Torque to 30-40 in-lb (3.3-4.5 N•m)
▲31	Torque to 130-150 in-lb (14.6-16.9 N•m)
▲32	Torque to 30-45 in-lb (3.3-5.0 N•m)
▲33	Torque to 90-110 in-lb (10.2-12.4 N•m)
▲35	Torque to 8-12 in-lb (0.9-1.35 N•m)
▲37	Torque to 70-90 in-lb (7.9-10.1 N•m)
▲42	Torque to 170-190 in-lb (19.2-21.4 N•m)
▲43	Torque to 200-230 in-lb (22.5-25.9 N•m)

GMAX II 5900/5900HD Standard Series

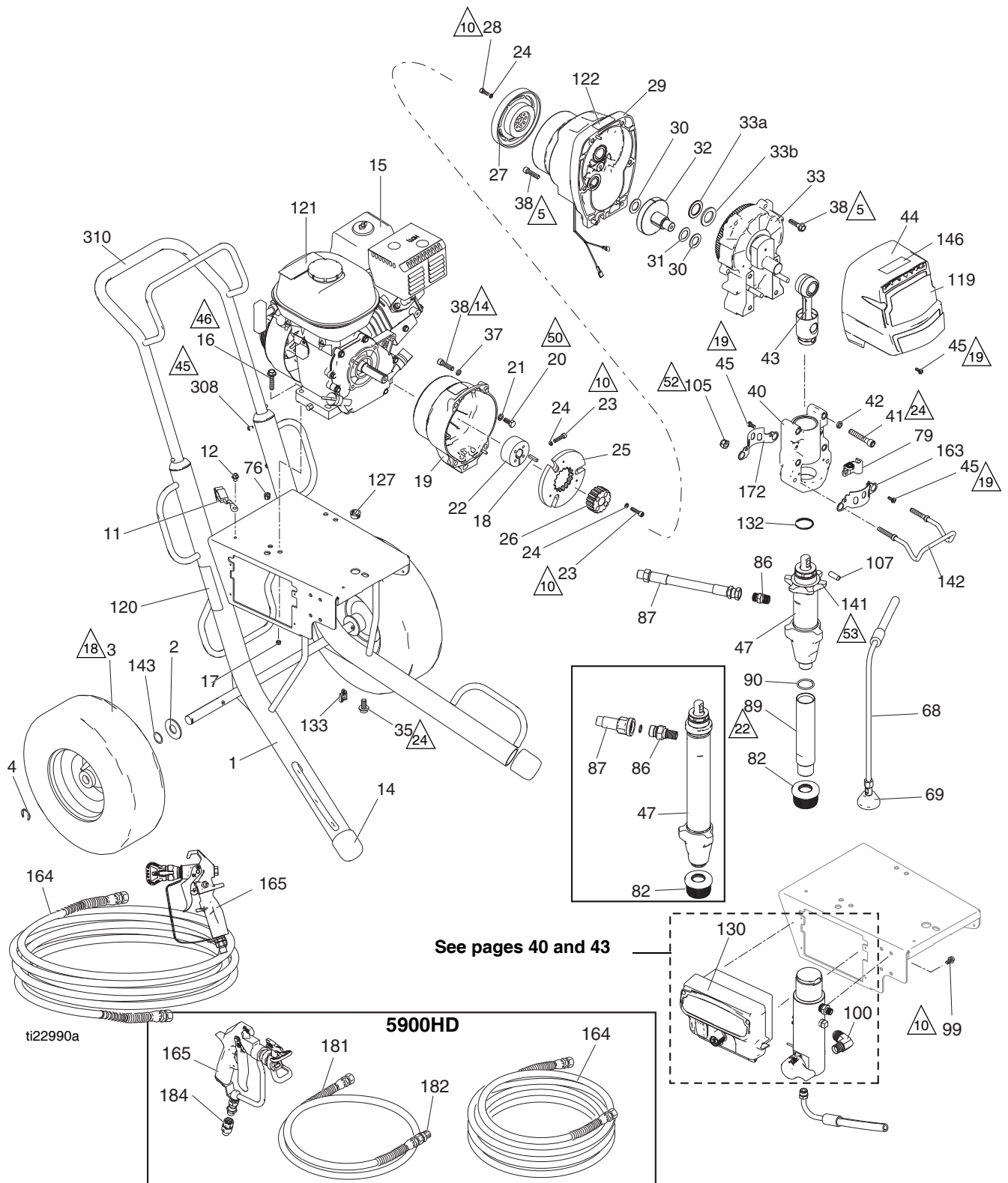

Parts List - GMAX II 5900/5900HD Standard Series

Ref.	Part	Description	Qty.	Ref.	Part	Description	Qty.
1	287370	FRAME, standard, cart	1		16X349	5900	1
2	156306	WASHER, flat	2		16X352	5900HD	1
3	119509	WHEEL, pneumatic	2	120▲	15F638	LABEL, GMAX warning fire & skin	1
4	15E891	CLIP, retaining	2	121▲	194126	LABEL, warning	1
11	237686	WIRE, ground assembly w/ clamp	1	122▲	290228	LABEL, caution	1
12	112798	SCREW, thread forming, hex hd	1	127	119569	BUSHING, strain relief	1
14	276974	CAP, leg	2	130	16X822	BOX, control	1
15	116080	ENGINE, gas, 6.5 HP, Honda	1	132	119778	SPRING, retaining	1
	25P296	ENGINE, gas, 6.5HP (China only)	1	133	114687	CLIP, retainer	1
16	110837	SCREW, flange, hex	2	141	193031	NUT, retaining	1
17	110838	NUT, lock	2	142★	16C457	HANGER, pail	1
18	183401	KEY, parallel	1	143	116038	WASHER, wave spring	2
19	15E277	HOUSING, clutch, mach 5900/7900	1	146	16X983	LABEL, standard series	1
20	108842	SCREW, cap, hex hd	4	155	15F354	FUNNEL, oil (not shown)	1
21	100214	WASHER, lock	4	160	102982	PACKING, o-ring, 5900HD	1
22	193680	COLLAR, shaft	1	163★	16X770	SHIELD, pump rod	1
23†	108803	SCREW, hex, socket head	6	164	240794	HOSE, coupled, 1/4 in. x 50 ft, 5900	1
24†	105510	WASHER, lock, spring (hi-collar)	10		240797	HOSE, coupled, 3/8 in. x 50ft, 5900HD	1
25†		ARMATURE, clutch, 5 in.	1	165	288420	GUN, contractor, RAC X, packaged, 5900	1
26†		HUB, armature	1		241705	GUN, spray, texture, 5900HD	1
27†		ROTOR, clutch, 5 in.	1	172	15C762	SHIELD, pump rod	1
28†	101682	SCREW, cap, sch	4	181	241735	HOSE, cpld, 1/4 in. x 3 ft, 5900HD	1
29	287465	HOUSING, pinion, 5900	1	182	159841	BUSHING, 7250 psi, 3/8 in. x 1/4 in., 5900HD	1
30	114672	WASHER, thrust	2	184	189018	SWIVEL, assembly, 5900HD	1
31	114699	WASHER, thrust	1	308	108795	SCREW, mach, pnh	4
32	287460	GEAR, combination, 5900	1	310	24A250	HANDLE, cart (standard only)	1
33	287469	HOUSING, drive, 5900, <i>includes 33a, 33b</i>	1	▲	16Y631	LABEL, warning	1
33a	116192	WASHER, thrust	1	▲	16Y632	LABEL, warning	1
33b	194173	WASHER	1	▲	16Y633	LABEL, warning	1
35	112395	SCREW, cap, flng hd	1				
37	104008	WASHER, lock, spring	4				
38	15C753	SCREW, mach, hex wash hd	6				
40★		HOUSING, bearing, 5900	1				
41★	114666	SCREW, cap, socket head	4				
42★	106115	WASHER, lock (hi-collar)	4				
43	24V021	ROD, connecting, 5900	1				
44	16Y748	COVER, front, 5900, <i>includes 45</i>	1				
45	118444	SCREW, mach, slot hex wash hd	8				
47		PUMP, displacement	1				
	16Y706	5900, <i>includes 86, 89, 90</i>	1				
	16X429	5900HD, <i>includes 86</i>	1				
68	244240	HOSE, coupled, <i>includes 69</i>	1				
69	241920	DEFLECTOR, threaded	1				
76	114678	BUSHING, strain relief	1				
79★	278204	CLIP, drain line	1				
82	189920	STRAINER, (1-11 1/2 NPSM)	1				
86		FITTING	1				
	196178	5900	1				
	16X834	5900HD	1				
87		HOSE, coupled	1				
	16X909	5900	1				
	16X905	5900HD	1				
89	248215	TUBE, intake	1				
90	118494	PACKING, o-ring	1				
99	113161	SCREW, flange, hex hd	3				
100	125926	FITTING, 90 deg (5900HD)	1				
105★	111040	NUT, lock, insert, nylock, 5/16	2				
107	15F856	PIN, pump, 5900	1				
119		LABEL, front, GMAX II 5900	1				

▲ Replacement Danger and Warning Labels, Tags and Cards are available at no cost.

† Included in Clutch Replacement Kit 241113.

★ Included in bearing housing kit 24V027

Part Specifications:

Ref.	Instruction
▲5	Torque to 190-210 in-lb (21.5-23.7 N•m)
▲10	Torque to 115-135 in-lb (12.9-15.3 N•m)
▲14	Torque to 130-150 in-lb (14.7-16.9 N•m)
▲18	Inflate tires to 28-32 psi (1.93-2.21 bar/0.193-0.221 MPa)
▲19	Torque to 30-35 in-lb (3.4-3.9 N•m)
▲22	Torque to 70-90 in-lb (7.9-10.2 N•m)
▲24	Torque to 23-29 ft-lb (31.2-39.3 N•m)
▲45	Torque to 25-35 in-lb (2.8-3.9 N•m)
▲46	Torque to 17-23 ft-lb (23.1-31.2 N•m)
▲50	Torque to 170-190 in-lb (19.2-21.5 N•m)
▲52	Torque to 200-230 in-lb (22.6-25.9 N•m)
▲53	Torque to 75 +/- 5 ft-lb (101.7 +/- 6.8 N•m)

GMAX II 5900 Lo-Boy Series

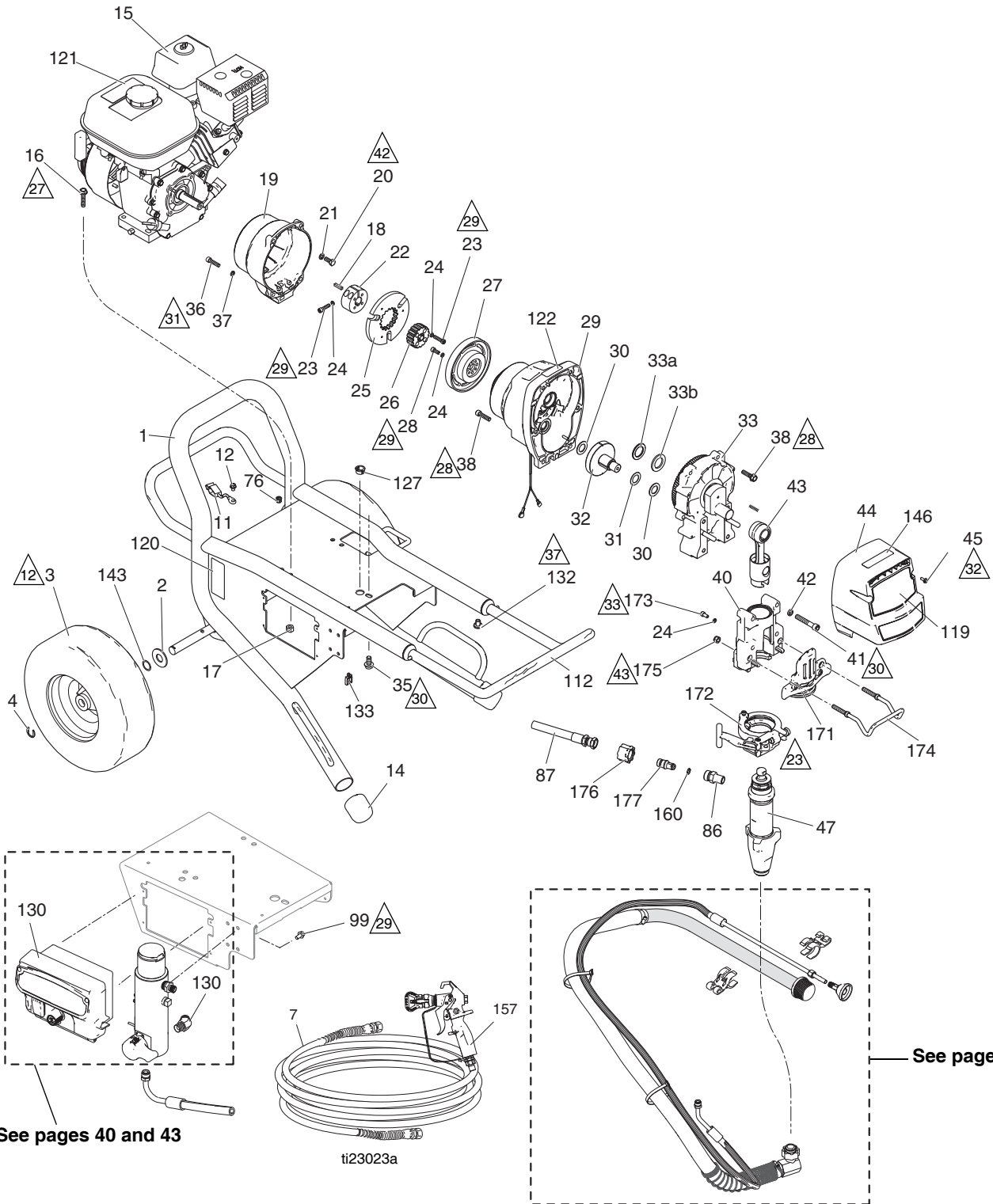

Parts List - GMAX II 5900 Lo-Boy Series

Ref.	Part	Description	Qty.	Ref.	Part	Description	Qty.
1	16Y519	FRAME, cart	1	120▲	15F638	LABEL, GMAX warning fire & skin	1
2	156306	WASHER, flat	2	121▲	194126	LABEL, warning	1
3	119509	WHEEL, pneumatic	2	122▲	290228	LABEL, caution	1
4	15E891	CLIP, retaining	2	127	119569	BUSHING, strain relief	1
7	240794	HOSE, coupled, 1/4 in. x 50 ft	1	130	16X822	BOX, control	1
11	237686	WIRE, ground assembly w/ clamp	1	132	109032	SCREW, mach, pnh	4
12	112798	SCREW, thread forming, hex hd	1	133	114687	CLIP, retainer	1
14	276974	CAP, leg	2	143	116038	WASHER, wave spring	2
15	116080	ENGINE, gas, 6.5 HP, Honda	1	146	16X979	LABEL, Proconnect	1
	25P296	ENGINE, gas, 6.5HP (China only)	1	157	288420	GUN, contractor, RAC X, packaged	1
16	110837	SCREW, flange, hex	2	160	107505	PACKING, o-ring	1
17	110838	NUT, lock	2	171★	16X385	PLATE, front, ProConnect II, 5900 Lo-Boy	1
18	183401	KEY, parallel	1	172★	16X324	CLAMP, pump, large, 5900 Lo-Boy	1
19	15E277	HOUSING, clutch, mach 5900/7900	1	173★	101550	SCREW, cap, sch, 5900 Lo-Boy	2
20	108842	SCREW, cap, hex hd	4	174★	16C457	HANGER, pail, 5900 Lo-Boy	1
21	100214	WASHER, lock	4	175★	111040	NUT, lock, insert, nylock, 5/16 5900 Lo-Boy	2
22	193680	COLLAR, shaft	1	176	120583	NUT, hand, 5900 Lo-Boy	1
23†	108803	SCREW, hex, socket head	6	177	16X833	FITTING, quick disconnect, 3/8 npsm, 5900 Lo-Boy	1
24†	105510	WASHER, lock, spring (hi-collar)	12	▲	16Y631	LABEL, warning	1
25†		ARMATURE, clutch, 5 in.	1	▲	16Y632	LABEL, warning	1
26†		HUB, armature	1	▲	16Y633	LABEL, warning	1
27†		ROTOR, clutch, 5 in.	1				
28†	101682	SCREW, cap, sch	4				
29	287465	HOUSING, pinion, 5900	1				
30	114672	WASHER, thrust	2				
31	114699	WASHER, thrust	1				
32	287460	GEAR, combination, 5900	1				
33	287469	HOUSING, drive, 5900, <i>includes 33a, 33b</i>	1				
33a	116192	WASHER, thrust	1				
33b	194173	WASHER	1				
35	112395	SCREW, cap, flng hd	1				
36	102962	SCREW, cap sch	4				
37	104008	WASHER, lock, spring	4				
38	15C753	SCREW, mach, hex wash hd	6				
40★		HOUSING, bearing, 5900	1				
41★	114666	SCREW, cap, socket head	4				
42★	106115	WASHER, lock (hi-collar)	4				
43	24V085	ROD, connecting, 5900	1				
44	16Y748	COVER, front, 5900, <i>includes 45</i>	1				
45★	118444	SCREW, mach, slot hex wash hd	4				
47	16X419	PUMP, displacement, 5900, <i>includes 86</i>	1				
76	114678	BUSHING, strain relief	1				
86	15J413	FITTING	1				
87	16X950	HOSE, coupled	1				
88	122533	FITTING, 45 deg	1				
99	113161	SCREW, flange, hex hd	3				
112	16Y780	HANDLE, cart	1				
119	16X349	LABEL, front, GMAX II 5900	1				

▲ Replacement Danger and Warning Labels, Tags and Cards are available at no cost.

† Included in Clutch Replacement Kit 241113.

★ Included in bearing housing kit 24V088

Part Specifications:

Ref.	Instruction
▲ ₁₂	Inflate tires to 28-32 psi (1.93-2.21 bar/0.193-0.221 MPa)
▲ ₂₃	Torque clamp adjustment bolt to 140-160 in-lb (15.8-18.1 N•m) with reference 47 installed and ProConnect in locked position.
▲ ₂₇	Torque to 17-23 ft-lb (23.1-31.2 N•m)
▲ ₂₈	Torque to 190-210 in-lb (21.5-23.7 N•m)
▲ ₂₉	Torque to 115-135 in-lb (12.9-15.3 N•m)
▲ ₃₀	Torque to 23-29 ft-lb (31.2-39.3 N•m)
▲ ₃₁	Torque to 130-150 in-lb (14.7-16.9 N•m)
▲ ₃₂	Torque to 30-45 in-lb (3.9-5.1 N•m)
▲ ₃₃	Torque to 90-110 in-lb (10.2-12.4 N•m)
▲ ₃₇	Torque to 25-35 in-lb (2.8-3.9 N•m)
▲ ₄₂	Torque to 170-190 in-lb (19.2-21.5 N•m)
▲ ₄₃	Torque to 200-230 in-lb (22.6-25.9 N•m)

Parts List - GMAX II 5900/5900HD ProContractor Series

Ref.	Part	Description	Qty.	Ref.	Part	Description	Qty.
1	24D047	FRAME, hose reel, cart	1	119		LABEL, front, GMAX II, 5900	
2	156306	WASHER, flat	2	16X349	5900		1
3	119509	WHEEL, pneumatic	2	16X352	5900HD		1
4	15E891	CLIP, retaining	2	120▲	15F638	LABEL, GMAX warning fire & skin	1
5	16C381	TUBE, GMAX 5900/7900	1	121▲	194126	LABEL, warning	1
9	288420	GUN, contractor, RAC X, packaged, 5900	1	122▲	290228	LABEL, caution	1
	241705	GUN, spray, texture, 5900HD	1	127	119569	BUSHING, strain relief	1
11	237686	WIRE, ground assembly w/ clamp	1	130	16X821	BOX, control	1
12	112798	SCREW, thread forming, hex hd	1	133	114687	CLIP, retainer	1
14	276974	CAP, leg	2	134	15F354	FUNNEL, oil (not shown)	1
15	114530	ENGINE, gas, 5.5 HP, Honda	1	143	116038	WASHER, wave spring	2
16	110837	SCREW, flange, hex	2	146	16X981	LABEL, Proconnect	1
17	110838	NUT, lock	2	150	162453	NIPPLE, 1/4 npsm x 1/4 npt, 5900	1
18	183401	KEY, parallel	1	151	240794	HOSE, coupled, 1/4 in. x 50 ft 5900	2
19	15E277	HOUSING, clutch, mach, 5900/7900	1		240797	HOSE, coupled, 3/8 in. x 50 ft, 5900HD	2
20	108842	SCREW, cap, hex hd	4	152	162485	ADAPTER, nipple, 5900HD	1
21	100214	WASHER, lock	4	153	241735	HOSE, cpld, 1/4 in. x 3 ft, 5900HD	1
22	193680	COLLAR, shaft	1	154	159841	BUSHING, 7250 psi, 3/8 x 1/4 in. 5900HD	1
23†	108803	SCREW, hex, socket head	6	155	189018	SWIVEL, assembly, 5900HD	1
24†★	105510	WASHER, lock, spring (hi-collar)	12	160		PACKING, o-ring	1
25†		ARMATURE, clutch, 5 in.	1		107505	5900	
26†		HUB, armature	1		102982	5900HD	
27†		ROTOR, clutch, 5 in.	1	164	15F947	SHIELD, magnetic	1
28†	101682	SCREW, cap, sch	4	171★	16X385	PLATE, front, 5900, PC II	1
29	287465	HOUSING, pinion, 5900	1	172★	16X324	CLAMP, pump, large	1
30	114672	WASHER, thrust	2	173★	101550	SCREW, cap, sch	2
31	114699	WASHER, thrust	1	174★	16C457	HANGER, pail	1
32	287460	GEAR, combination, 5900	1	175★	111040	NUT, lock, insert, nylock, 5/16	2
33	287469	HOUSING, drive, 5900, <i>includes 33a, 33b</i>	1	176	120583	NUT, hand	1
33a	116192	WASHER, thrust	1	177	16X833	FITTING, quick disconnect, 3/8 npsm	1
33b	194173	WASHER	1	▲	16Y631	LABEL, warning	1
34	116618	MAGNET	1	▲	16Y632	LABEL, warning	1
35	112395	SCREW, cap, flng hd	1	▲	16Y633	LABEL, warning	1
36	102962	SCREW, cap sch	4				
37	104008	WASHER, lock, spring	4				
38	15C753	SCREW, mach, hex wash hd	6				
39	119562	SWITCH, reed w/connector	1				
40★		HOUSING, bearing, 5900	1				
41★	114666	SCREW, cap, socket head	4				
42★	106115	WASHER, lock (hi-collar)	4				
43	24V085	ROD, connecting, 5900	1				
44	16Y748	COVER, front, 5900, <i>includes 45</i>	1				
45★	118444	SCREW, mach, slot hex wash hd	5				
47		PUMP, displacement					
	16X419	5900 (includes 86, 89, 90)	1				
	16X421	5900HD, <i>includes 86</i>	1				
68	244240	HOSE, coupled, <i>includes 69</i>	1				
69	241920	DEFLECTOR, threaded	1				
76	114678	BUSHING, strain relief	1				
79★	16X203	CLIP, drain line	1				
82	189920	STRAINER, (1-11 1/2 NPSM)	1				
86		FITTING, pump, QD	1				
	16Y579	5900					
	16X834	5900HD					
87		HOSE, coupled	1				
	16X904	3/8 in., 5900					
	16X905	1/2 in., 5900HD					
89	248215	TUBE, intake	1				
90	118494	PACKING, o-ring	1				
93	287253	TOOL BOX, <i>includes 94</i>	1				
94	118852	SCREW, thd forming, hex washer hd	3				
98	125926	FITTING, 90 deg	1				
99	113161	SCREW, flange, hex hd	3				
100	278083	GUIDE, hose	1				
101	117633	SCREW, slot hex wash hd	2				
108	114528	SCREW, mach, phillips, pnhd	2				





▲ Replacement Danger and Warning Labels, Tags and Cards are available at no cost.

† Included in Clutch Replacement Kit 241113.

★ Included in bearing housing kit 24V088

Part Specifications:

Ref.	Instruction
▲ ₁₂	Inflate tires to 28-32 psi (1.93-2.21 bar/0.193-0.221 MPa)
▲ ₂₃	Torque clamp adjustment bolt to 140-160 in-lb (15.8-18.1 N•m) with reference 47 installed and ProConnect in locked position.
▲ ₂₄	Torque to 38-42 ft-lb (51.5-56.9 N•m)
▲ ₂₅	Torque to 120-130 in-lb (13.6-14.7 N•m)
▲ ₂₆	Torque to 40-45 in-lb (4.5-5.1 N•m)
▲ ₂₇	Torque to 17-23 ft-lb (23.1-31.2 N•m)
▲ ₂₈	Torque to 190-210 in-lb (21.5-23.7 N•m)
▲ ₂₉	Torque to 115-135 in-lb (12.9-15.3 N•m)
▲ ₃₀	Torque to 23-29 ft-lb (31.2-39.3 N•m)
▲ ₃₁	Torque to 130-150 in-lb (14.7-15.9 N•m)
▲ ₃₂	Torque to 30-45 in-lb (3.4-5.1 N•m)

Ref.	Instruction
	Torque to 90-110 in-lb (10.2-12.4 N•m)
	Torque to 8-12 in-lb (0.9-1.4 N•m)
	Torque to 70-90 in-lb (7.9-10.2 N•m)
	Torque to 170-190 in-lb (19.2-21.2 N•m)
	Torque to 200-230 in-lb (22.6-25.9 N•m)

Parts List - GMAX II 5900 IronMan Series

Ref.	Part	Description	Qty.	Ref.	Part	Description	Qty.																												
1	16X778	FRAME, cart	1	120▲	15F638	LABEL, GMAX warning fire & skin	1																												
2	156306	WASHER, flat	2	121▲	194126	LABEL, warning	1																												
3	122267	WHEEL, pneumatic	2	122▲	290228	LABEL, caution	1																												
4	120211	CLIP, retaining	2	127	119569	BUSHING, strain relief	1																												
11	237686	WIRE, ground assembly w/ clamp	1	130	16X821	BOX, control	1																												
12	112798	SCREW, thread forming, hex hd	1	133	114687	CLIP, retainer	1																												
14	15C871	CAP, leg	2	134	15F354	FUNNEL, oil (not shown)	1																												
15	114530	ENGINE, gas, 5.5 HP, Honda	1	143	116038	WASHER, wave spring	2																												
16	110837	SCREW, flange, hex	2	146	16X982	LABEL, ProConnect	1																												
17	110838	NUT, lock	2	157	24A139	GUN, silver, RAC X, packaged	1																												
18	183401	KEY, parallel	1	160	107505	PACKING, o-ring	1																												
19	15E277	HOUSING, clutch, mach, 5900/7900	1	164	15F947	SHIELD, magnetic	1																												
20	108842	SCREW, cap, hex hd	4	171★	16X385	PLATE, front, 5900, PC II	1																												
21	100214	WASHER, lock	4	172★	16X324	CLAMP, pump, large	1																												
22	193680	COLLAR, shaft	1	173★	101550	SCREW, cap, sch	2																												
23†	108803	SCREW, hex, socket head	6	174★	16C457	HANGER, pail	1																												
24†	105510	WASHER, lock, spring (hi-collar)	12	175★	111040	NUT, lock, insert, nylock, 5/16	2																												
25†		ARMATURE, clutch, 5 in.	1	176	120583	NUT, hand	1																												
26†		HUB, armature	1	177	16X833	FITTING, quick, disconnect, 3/8 npsm	1																												
27†		ROTOR, clutch, 5 in.	1	180	240797	HOSE, coupled, 3/8 in. x 50 ft	1																												
28†	101682	SCREW, cap, sch	4	181	240794	HOSE, coupled, 1/4 in. x 50 ft	1																												
29	287465	HOUSING, pinion, 5900	1	182	164672	ADAPTER	1																												
30	114672	WASHER, thrust	2	184	189018	SWIVEL, assembly	1																												
31	114699	WASHER, thrust	1	▲	16Y631	LABEL, warning	1																												
32	287460	GEAR, combination, 5900	1	▲	16Y632	LABEL, warning	1																												
33	287469	HOUSING, drive, 5900, <i>includes 33a, 33b</i>	1	▲	16Y633	LABEL, warning	1																												
33a	116192	WASHER, thrust	1	▲ <i>Replacement Danger and Warning Labels, Tags and Cards are available at no cost.</i>																															
33b	194173	WASHER	1	† <i>Included in Clutch Replacement Kit 241113.</i>																															
34	116618	MAGNET	1	★ <i>Included in bearing housing kit 24V088</i>																															
35	112395	SCREW, cap, flng hd	1	Part Specifications:																															
36	102962	SCREW, cap sch	4	<table border="1"> <thead> <tr> <th>Ref.</th> <th>Instruction</th> </tr> </thead> <tbody> <tr> <td>23</td> <td>Torque clamp adjustment bolt to 140-160 in-lb (15.8-18.1 N•m) with reference 47 installed and ProConnect in locked position.</td> </tr> <tr> <td>26</td> <td>Torque to 40-45 in-lb (4.5-5.1 N•m)</td> </tr> <tr> <td>27</td> <td>Torque to 17-23 ft-lb (23.1-31.2 N•m)</td> </tr> <tr> <td>28</td> <td>Torque to 190-210 in-lb (21.5-23.7 N•m)</td> </tr> <tr> <td>29</td> <td>Torque to 115-135 in-lb (12.9-15.3 N•m)</td> </tr> <tr> <td>30</td> <td>Torque to 23-29 ft-lb (31.2-39.4 N•m)</td> </tr> <tr> <td>31</td> <td>Torque to 130-150 in-lb (14.7-16.9 N•m)</td> </tr> <tr> <td>32</td> <td>Torque to 30-45 in-lb (3.4-5.1 N•m)</td> </tr> <tr> <td>33</td> <td>Torque to 90-110 in-lb (10.2-12.4 N•m)</td> </tr> <tr> <td>35</td> <td>Torque to 8-12 in-lb (0.9-1.4 N•m)</td> </tr> <tr> <td>37</td> <td>Torque to 70-90 in-lb (7.9-10.2 N•m)</td> </tr> <tr> <td>42</td> <td>Torque to 170-190 in-lb (19.2-21.5 N•m)</td> </tr> <tr> <td>43</td> <td>Torque to 200-230 in-lb (22.6-25.9 N•m)</td> </tr> </tbody> </table>				Ref.	Instruction	23	Torque clamp adjustment bolt to 140-160 in-lb (15.8-18.1 N•m) with reference 47 installed and ProConnect in locked position.	26	Torque to 40-45 in-lb (4.5-5.1 N•m)	27	Torque to 17-23 ft-lb (23.1-31.2 N•m)	28	Torque to 190-210 in-lb (21.5-23.7 N•m)	29	Torque to 115-135 in-lb (12.9-15.3 N•m)	30	Torque to 23-29 ft-lb (31.2-39.4 N•m)	31	Torque to 130-150 in-lb (14.7-16.9 N•m)	32	Torque to 30-45 in-lb (3.4-5.1 N•m)	33	Torque to 90-110 in-lb (10.2-12.4 N•m)	35	Torque to 8-12 in-lb (0.9-1.4 N•m)	37	Torque to 70-90 in-lb (7.9-10.2 N•m)	42	Torque to 170-190 in-lb (19.2-21.5 N•m)	43	Torque to 200-230 in-lb (22.6-25.9 N•m)
Ref.	Instruction																																		
23	Torque clamp adjustment bolt to 140-160 in-lb (15.8-18.1 N•m) with reference 47 installed and ProConnect in locked position.																																		
26	Torque to 40-45 in-lb (4.5-5.1 N•m)																																		
27	Torque to 17-23 ft-lb (23.1-31.2 N•m)																																		
28	Torque to 190-210 in-lb (21.5-23.7 N•m)																																		
29	Torque to 115-135 in-lb (12.9-15.3 N•m)																																		
30	Torque to 23-29 ft-lb (31.2-39.4 N•m)																																		
31	Torque to 130-150 in-lb (14.7-16.9 N•m)																																		
32	Torque to 30-45 in-lb (3.4-5.1 N•m)																																		
33	Torque to 90-110 in-lb (10.2-12.4 N•m)																																		
35	Torque to 8-12 in-lb (0.9-1.4 N•m)																																		
37	Torque to 70-90 in-lb (7.9-10.2 N•m)																																		
42	Torque to 170-190 in-lb (19.2-21.5 N•m)																																		
43	Torque to 200-230 in-lb (22.6-25.9 N•m)																																		
37	104008	WASHER, lock, spring	4																																
38	15C753	SCREW, mach, hex wash hd	6																																
39	119562	SWITCH, reed w/connector	1																																
40★		HOUSING, bearing, 5900	1																																
41★	114666	SCREW, cap, socket head	4																																
42	106115	WASHER, lock (hi-collar)	4																																
43	24V085	ROD, connecting, 5900	1																																
44	16Y748	COVER, front, 5900, <i>includes 45</i>	1																																
45★	118444	SCREW, mach, slot hex wash hd	5																																
47	16X420	PUMP, displacement, 5900, <i>includes 86, 89, 90</i>	1																																
68	244240	HOSE, coupled, <i>includes 69</i>	1																																
69	241920	DEFLECTOR, threaded	1																																
76	114678	BUSHING, strain relief	1																																
79★	16X203	CLIP, drain line	1																																
82	15V573	STRAINER, (1-11 1/2 NPSM)	1																																
86	16Y579	FITTING	1																																
87	16X904	HOSE, coupled	1																																
89	248215	TUBE, intake	1																																
90	118494	PACKING, o-ring	1																																
98	125926	FITTING, 90 deg	1																																
99	113161	SCREW, flange, hex hd	3																																
108	114528	SCREW, mach, phillips, pnhd	2																																
119	16X349	LABEL, front, GMAX II, 5900	1																																

GMAX II 5900 Convertible Series

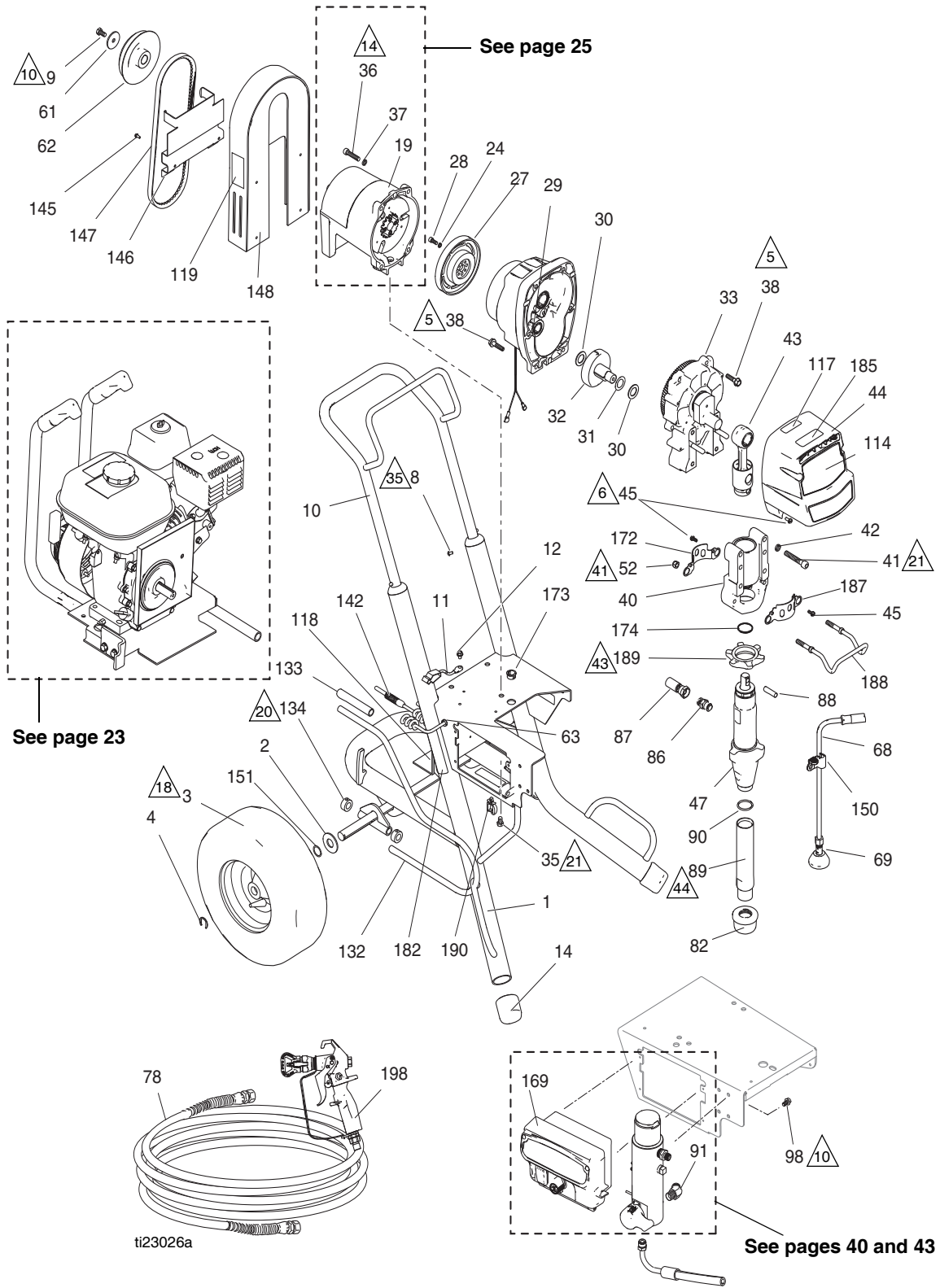

Parts List - GMAX II 5900 Convertible Series

Ref.	Part	Description	Qty.	Ref.	Part	Description	Qty.
1	287423	FRAME, cart	1	133	114808	CAP, vinyl	1
2	156306	WASHER, flat	2	134	198772	COLLAR, torsion bar	2
3	119509	WHEEL, pneumatic	2	142	119584	CORD, power, convertible	1
4	15E891	CLIP, retaining	2	145	100078	SCREW, thd forming, hex hd	4
8	108795	SCREW, mach, pnh	4	146	198996	BRACKET, belt guide	1
9	121727	SCREW, cap, hex hd	1	147	193547	BELT, Vee, 30	1
10	24A250	HANDLE, cart	1	148	198691	GUARD, belt	1
11	237686	WIRE, ground assembly w/ clamp	1	150★	278204	CLIP, drain line	1
12	112798	SCREW, thread forming, hex hd	1	151	116038	WASHER, wave spring	2
14	276974	CAP, leg	2	155	15F354	FUNNEL, oil (not shown)	1
19	287519	HOUSING, clutch	1	169	16X822	BOX, control	1
24*	105510	WASHER, lock, spring (hi-collar)	4	172	15C762	SHIELD, pump rod	1
27*		ROTOR, clutch, 5 in.	1	173	119569	BUSHING, strain relief	1
28*	101682	SCREW, cap, sch	4	174	119778	SPRING, retaining	1
29	287465	HOUSING, pinion, 5900	1	182▲	15F638	LABEL, warning	1
30	114672	WASHER, thrust	2	185	16X983	LABEL	1
31	114699	WASHER, thrust	1	187★	16X770	SHIELD, pump rod	1
32	287460	GEAR, combination	1	188★	16C457	HANGER, pail	1
33	287700	HOUSING, drive, convert	1	189	193031	NUT, retaining	1
35	112395	SCREW, cap, flng hd	3	190	114687	CLIP, retainer	1
36	102962	SCREW, cap sch	4	198	288420	GUN, contractor, RAC X, packaged	1
37	104008	WASHER, lock, spring	4	▲	16Y631	LABEL, warning	1
38	15C753	SCREW, mach, torx, hex wash hd	6	▲	16Y632	LABEL, warning	1
40★		HOUSING, bearing	1	▲	16Y633	LABEL, warning	1
41★	114666	SCREW, cap, socket hd	4				
42★	106115	WASHER, lock spring (hi-collar)	4				
43	24V021	ROD, connecting	1				
44	16Y748	COVER, front; <i>includes 45</i>	1				
45★	118444	SCREW, machine hex washer head	8				
47	16Y706	PUMP, displacement, <i>includes 86, 89, 90</i>	1				
52★	111040	NUT, lock, insert, nylock, 5/16	2				
61	112717	WASHER	1				
62	198688	PULLEY, engine	1				
63	114425	BUSHING, strain relief	1				
68	244240	HOSE, coupled, <i>includes 69</i>	1				
69	241920	DEFLECTOR, threaded	1				
78	240794	HOSE, coupled, 1/4 in. x 50 ft	1				
82	189920	STRAINER, (1-11 1/2 npsm)	1				
86	196178	FITTING, pump	1				
87	16Y667	HOSE, coupled	1				
88	15F856	PIN, pump	1				
89†	248215	TUBE, intake	1				
90†	118494	O-RING	1				
91	122533	FITTING, 45 deg	1				
98	113161	SCREW, flange, hex hd	3				
114	16X358	LABEL, brand	1				
117▲	290228	LABEL, caution	1				
118▲	804495	LABEL, warning	1				
119	195098	LABEL, instruction (English)	1				
132	245688	BAR, torsion, <i>includes 133, 134</i>	1				

▲ Replacement Danger and Warning labels, tags, and cards are available at no cost.

* Included in Clutch Repair Kit 241113

★ Included in bearing housing kit 24V027

Part Specifications:

Ref.	Instruction
5	Torque to 190-210 in-lb (21.5-23.7 N•m)
6	Torque to 30-35 in-lb (3.4-3.9 N•m)
10	Torque to 115-135 in-lb (12.9-15.3 N•m)
14	Torque to 130-150 in-lb (14.7-16.9 N•m)
18	Inflate tires to 28-32 psi (1.93-2.21 bar/0.193-0.221 MPa)
20	Torque to 10-15 in-lb (1.1-1.7 N•m)
21	Torque to 20-30 ft-lb (27.1-40.1 N•m)
35	Torque to 25-35 in-lb (2.8-3.9 N•m)
41	Torque to 200-230 in-lb (22.5-25.9 N•m)
43	Torque to 75 +/- 5 ft-lb (101.6 +/- 6.7 N•m)
44	Torque to 70-90 in-lb (7.9-10.1 N•m)

GMAX II 5900 Convertible Series

Engine Detail - Parts List

Ref.	Part	Description	Qty.	Ref.	Part	Description	Qty.								
15	114530	ENGINE, gas, 5.5 Honda	1	136	116149	SPACER	1								
16	114653	SCREW, cap, flange hd	4	137	194414	BRACKET, J-box	1								
17	110996	NUT, flng hd, hex	6	138	114813	SCREW, mach, hex washer hd	1								
18	183401	KEY, parallel	1	139	114678	BUSHING, snap	1								
20	119717	SCREW, cap, hex hd	1	140	194181	BOX, junction, engine	1								
61	112717	WASHER	1	141	114805	JACK, 1/4 engine	1								
115	194126	LABEL, warning	1	143	15E896	PULLEY, engine	1								
124	245272	BASE, mounting	1	144	15B314	SLEEVE, motor shaft	1								
125	116139	GRIP, handle	2	Part Specifications:											
126	198689	BRACKET, belt guard (motor)	1	<table border="1"> <thead> <tr> <th>Ref.</th> <th>Instruction</th> </tr> </thead> <tbody> <tr> <td></td> <td>Torque to 190-210 in-lb (21.5-23.7 N•m)</td> </tr> <tr> <td></td> <td>Torque to 115-135 in-lb (12.9-15.3 N•m)</td> </tr> <tr> <td></td> <td>Torque to 17-23 ft-lb (23.0-31.1 N•m)</td> </tr> </tbody> </table>				Ref.	Instruction		Torque to 190-210 in-lb (21.5-23.7 N•m)		Torque to 115-135 in-lb (12.9-15.3 N•m)		Torque to 17-23 ft-lb (23.0-31.1 N•m)
Ref.	Instruction														
	Torque to 190-210 in-lb (21.5-23.7 N•m)														
	Torque to 115-135 in-lb (12.9-15.3 N•m)														
	Torque to 17-23 ft-lb (23.0-31.1 N•m)														
127	112406	SCREW	3												
128	198997	BRACKET, tension	1												
129	198693	HANDLE, slide, engine	2												
130	198695	BRACKET, torsion bar	1												
131	110963	SCREW, cap, hex hd, flange	2												
135	114816	NUT, hex	1												

GMAX II 5900 Convertible Series

Clutch Housing - Parts Drawing and List

Ref	Part	Description	Qty	Ref	Part	Description	Qty
19	287519	HOUSING, clutch, <i>includes 19b, 19c, 19e, 19j & 19k</i>	1	24	105510*	WASHER, lock, spring (hi-collar)	8
19b	114962	RING, retaining, internal	1	25	*	ARMATURE, clutch, 5 in.	1
19c	287422	SHAFT, drive, input	1	26	*	HUB, armature	1
19e	15E887	HOUSING, clutch	1	27	*	ROTOR, clutch, 5 in.	1
19j	115078	O-RING	1	28	101682*	SCREW, cap, sch	4
19k	115079	O-RING	1	* Included in Clutch Repair Kit 241113			
21	15E894	STOP, armature	1				
23	108803*	SCREW, hex, socket head	4				

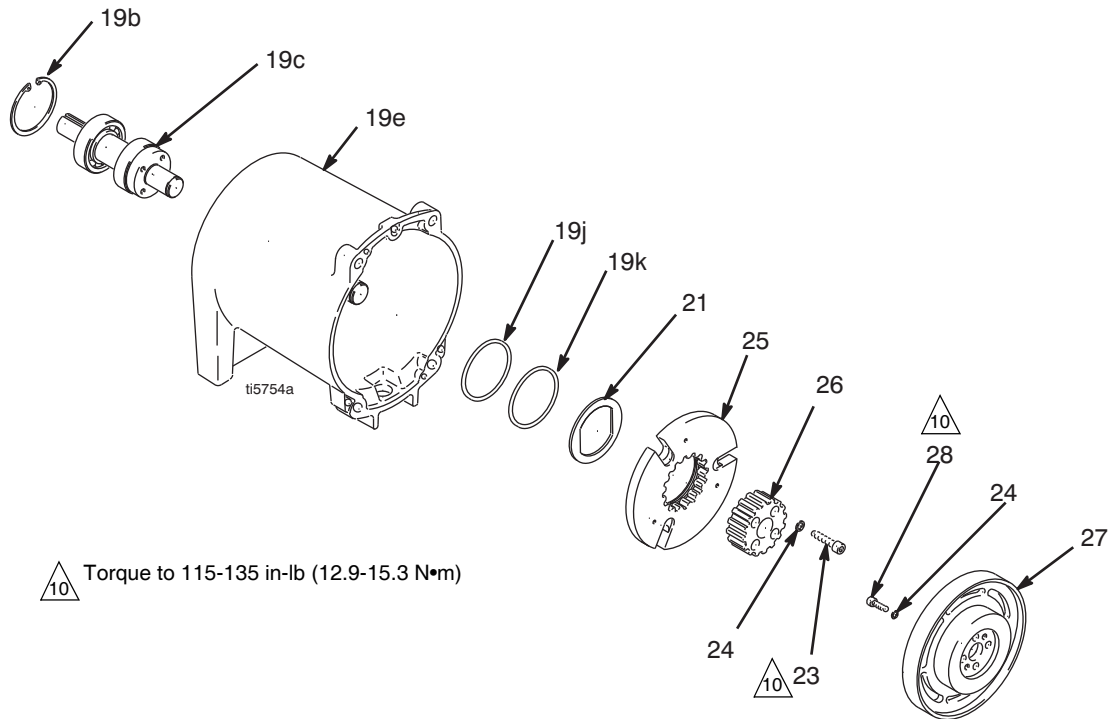

GMAX II 7900/TexSpray 7900HD Standard Series/Roof Rig

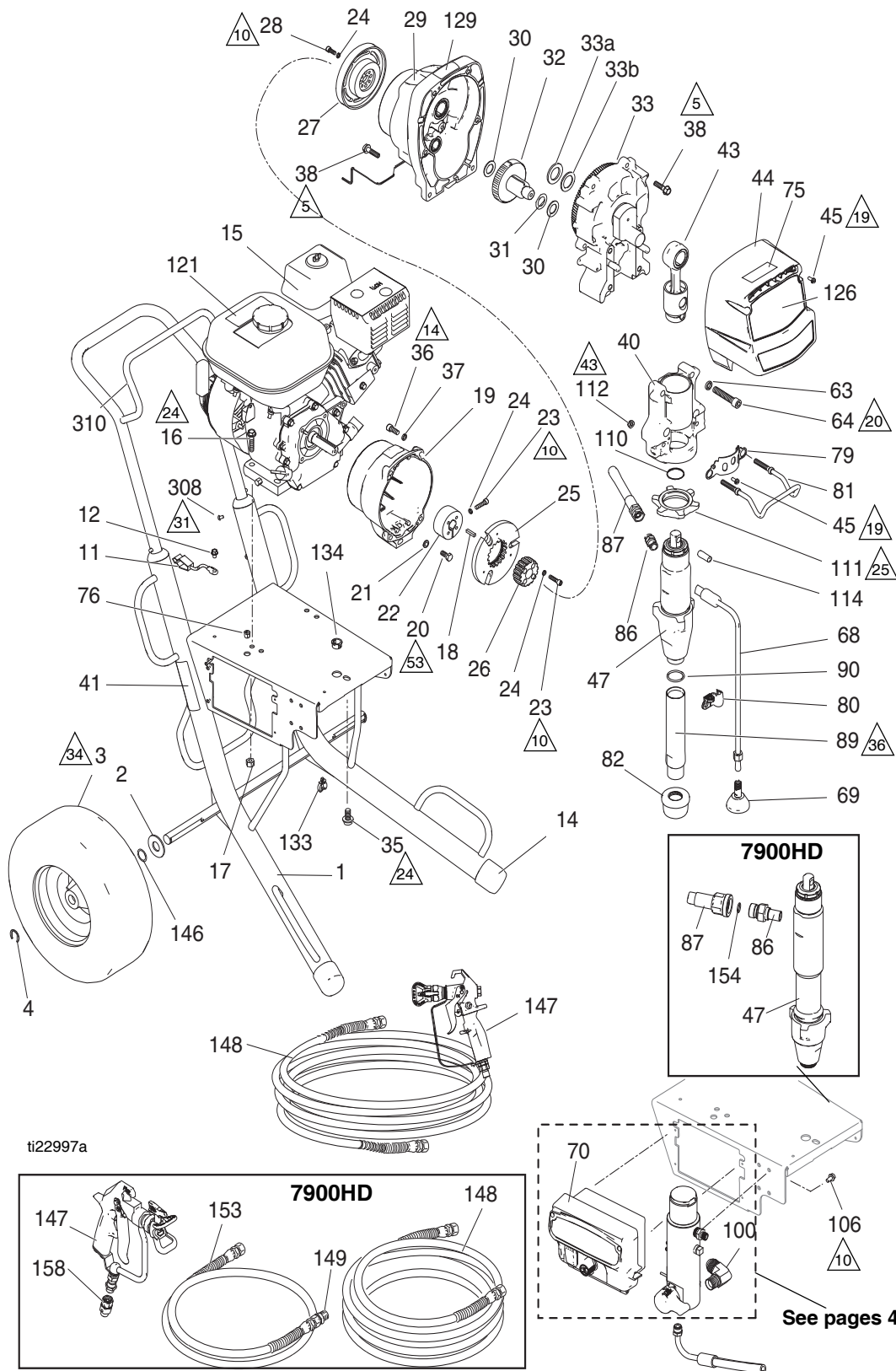

Parts List - GMAX II 7900/TexSpray 7900HD Standard Series/Roof Rig

Ref.	Part	Description	Qty.	Ref.	Part	Description	Qty.
1	287370	FRAME	1		16X905	TexSpray, 7900HD	1
2	156306	WASHER, flat	2	89	248215	TUBE, intake, <i>includes 90</i>	1
3	119509	WHEEL, pneumatic	2	90	118494	PACKING, o-ring, 7900	1
4	15E891	CLIP, retaining	2	100	125926	FITTING, 90 deg	1
11	237686	WIRE, ground assembly w/ clamp	1	106	113161	SCREW, flange, hex hd	3
12	112798	SCREW, thread forming, hex hd	1	110	119677	SPRING, retaining	1
14	276974	CAP, leg	2	111	193394	NUT, retaining	1
15	116080	ENGINE, gas, 6.5 HP, Honda	1	112	111040★	NUT, lock, insert, nylock, 5/16	2
	25P296	ENGINE, gas, 6.5HP (China only)	1	114	19B144	PIN, pump	1
16	110837	SCREW, flange, hex	2	121▲	194126	LABEL, warning	1
17	110838	NUT, lock	2	126	16X350	LABEL, identification, 7900	1
18	183401	KEY, parallel	1		16X355	LABEL, identification, 7900HD	1
19	15E277	HOUSING, clutch, mach, 5900/7900	1	129▲	290228	LABEL, caution	1
20	108842	SCREW, cap, hex hd	4	133	114687	CLIP, retainer	1
21	100214	WASHER, lock	4	134	119569	BUSHING, strain relief	1
22	193680	COLLAR, shaft	1	145	15F354	FUNNEL, oil (not shown)	1
23†	108803	SCREW, hex, socket head	6	146	116038	WASHER, wave spring	2
24†	105510	WASHER, lock, spring	10	147	288420	GUN, contractor, RAC X, 7900	1
25†		ARMATURE, clutch, 5 in.	1		241705	GUN, spray, texture, 7900HD Roof Rig	1
26†		HUB, armature	1	148	240797	HOSE, coupled, 3/8 in. x 50 ft	1
27†		ROTOR, clutch, 5 in.	1	149	159841	O-RING	1
28†	101682	SCREW, cap, sch	4	153	241735	HOSE, coupled, 1/4 in. x 3 ft	1
29	287466	HOUSING, pinion, 7900	1	154	102982	O-RING, TexSpray, 7900HD	1
30	114672	WASHER, thrust	2	158	189018	SWIVEL, assembly, 7900 HD	1
31	114699	WASHER, thrust	1	308	108795	SCREW, mach, pnh	4
32	287459	GEAR, combination, 7900	1	310	24A250	HANDLE, cart	1
33	287470	HOUSING, drive, 7900, <i>includes 33a,33b</i>	1	▲	16Y631	LABEL, warning	1
33a	116192	WASHER, thrust	1	▲	16Y632	LABEL, warning	1
33b	194173	WASHER	1	▲	16Y633	LABEL, warning	1
35	112395	SCREW, cap, flng hd	1				
36	102962	SCREW, cap sch	4				
37	104008	WASHER, lock, spring	4				
38	15C753	SCREW, mach, hex wash hd	6				
40★		HOUSING, bearing, 7900	1				
41▲	15F638	LABEL, GMAX warning fire & skin	1				
43	24V022	ROD, connecting, 7900	1				
44	16Y749	COVER, front, 7900 (includes 45)	1				
45★	118444	SCREW, mach, slot hex wash hd	6				
47	16X423	PUMP, displacement, 7900, <i>includes 86, 89, 90</i>	1				
	16X425	PUMP, displacement, 7900HD, <i>includes 86</i>	1				
63★	112600	WASHER, lock, spring	4				
64★	112599	SCREW, cap, socket head	4				
68	244240	HOSE, coupled, <i>includes 69</i>	1				
69	241920	DEFLECTOR, threaded	1				
70	16X822	BOX, control, standard	1				
75	16X983	LABEL, standard series	1				
76	114678	BUSHING, strain relief	1				
79★	16X770	SHIELD, pump rod	1				
80★	278204	CLIP, drain line	1				
81	16C457	HANGER, pail	1				
82	189920	STRAINER, (1-11 1/2 NPSM)	1				
86		FITTING, pump	1				
	196178	7900	1				
	16X835	TexSpray, 7900HD	1				
87		HOSE, coupled	1				
	16X909	7900	1				

▲ Replacement Danger and Warning Labels, Tags and Cards are available at no cost.

† Included in Clutch Replacement Kit 241113.

★ Included in bearing housing kit 24V028

Part Specifications:

Ref.	Instruction
5	Torque to 190-210 in-lb (21.5-23.7 N•m)
10	Torque to 115-135 in-lb (12.9-15.3 N•m)
14	Torque to 130-150 in-lb (14.7-16.9 N•m)
19	Torque to 30-35 in-lb (3.4-3.9 N•m)
20	Torque to 35-45 ft-lb (47.5-61.0 N•m)
24	Torque to 20 +/- 3 ft-lb (21.7 +/- 4.1 N•m)
28	Torque to 75 +/- 5 ft-lb (101.7 +/- 6.8 N•m)
31	Torque to 25-35 in-lb (2.8-3.9 N•m)
34	Inflate tires to 28-32 psi (1.93-2.21 bar/0.193-0.221 MPa)
36	Torque to 70-90 in-lb (7.9-10.2 N•m)
43	Torque to 200-230 in-lb (22.6-25.6 N•m)
53	Torque to 170-190 in-lb (19.2-21.5 N•m)

Parts List - GMAX II 7900/TexSpray 7900HD ProContractor Series

Ref.	Part	Description	Qty.	Ref.	Part	Description	Qty.
1	24D047	FRAME, hose reel	1	90	118494	PACKING, o-ring, 7900	1
2	156306	WASHER, flat	2	93	287253	TOOL BOX, <i>includes 94</i>	1
3	119509	WHEEL, pneumatic	2	94	118852	SCREW, thd forming, hex washer HD	3
4	15E891	CLIP, retaining	2	100	125926	FITTING, 90 deg	1
5	16C381	TUBE, hydraulic, GMAX 5900/7900	1	106	113161	SCREW, flange, hex hd	3
11	237686	WIRE, ground assembly w/ clamp	1	107	278083	GUIDE, hose	1
12	112798	SCREW, thread forming, hex hd	1	108	117633	SCREW, slot hex wash hd	2
14	276974	CAP, leg	2	109	15F947	SHIELD, magnetic	1
15	116080	ENGINE, gas, 6.5 HP, Honda	1	115	114528	SCREW, mach, phillips, pnhd	2
	25P296	ENGINE, gas, 6.5HP (China only)	1	121▲	194126	LABEL, warning	1
16	110837	SCREW, flange, hex	2	126	16X350	LABEL, identification, 7900	1
17	110838	NUT, lock	2		16X355	LABEL, identification, TexSpray 7900	
18	183401	KEY, parallel	1	129	290228	LABEL, caution	1
19	15E277	HOUSING, clutch, mach (5900/7900)	1	133	114687	CLIP, retainer	1
20	108842	SCREW, cap, hex hd	4	134	119569	BUSHING, strain relief	1
21	100214	WASHER, lock	4	143	15F354	FUNNEL, oil (not shown)	1
22	193680	COLLAR, shaft	1	146	116038	WASHER, wave spring	2
23†	108803	SCREW, hex, socket head	6	149		O-RING	
24†	105510	WASHER, lock, spring	12		107505	7900	1
25†		ARMATURE, clutch, 5 in.	1		102982	TexSpray, 7900HD	1
26†		HUB, armature	1	171★	16X209	PLATE, front, ProConnect II	1
27†		ROTOR, clutch, 5 in.	1	172★	16X324	CLAMP, pump, large	1
28†	101682	SCREW, cap, sch	4	173★	101550	SCREW, cap, sch	2
29	287466	HOUSING, pinion, 7900	1	174★	16C457	HANGER, pail	1
30	114672	WASHER, thrust	2	175★	112746	NUT, lock, nylon, thin pattern	2
31	114699	WASHER, thrust	1	176	120583	NUT, hand, 7900 only	1
32	287459	GEAR, combination, 7900	1	177	16X833	FITTING, quick disconnect, 3/8 npsm, 7900 only	1
33	287470	HOUSING, drive, 7900, <i>includes 33a, 33b</i>	1	400	240797	HOSE, coupled, 3/8 in. x 50 ft, 7900	1
33a	116192	WASHER, thrust	1		240797	HOSE, coupled, 3/8 in. x 50 ft, 7900HD	2
33b	194173	WASHER	1	401	240794	HOSE, coupled, 1/4 in. x 50 ft, 7900	1
34	116618	MAGNET	1	402	164672	ADAPTER, 7900	1
35	112395	SCREW, cap, flng hd	1		162485	ADAPTER, 7900HD	
36	102962	SCREW, cap sch	4	403	241735	HOSE, coupled, 1/4 in. x 3 ft mxl, 7900HD	1
37	104008	WASHER, lock, spring	4	404	159841	BUSHING, 7250 psi, 3/8 x 1/4 in., 7900HD	1
38	15C753	SCREW, mach, hex wash hd	6	405	189018	SWIVEL	1
39	119562	SWITCH, reed w/connector	1	▲	16Y631	LABEL, warning	1
40★		HOUSING, bearing, 7900	1	▲	16Y632	LABEL, warning	1
41▲	15F638	LABEL, GMAX warning fire & skin	1	▲	16Y633	LABEL, warning	1
43	24V086	ROD, connecting, 7900	1				
44	16Y749	COVER, front, 7900, <i>includes 45</i>	1				
45★	118444	SCREW, mach, slot hex wash hd	5				
47	16X426	PUMP, displacement, 7900, <i>includes 86, 89, 90</i>	1				
	16X427	PUMP, displacement, 7900HD, <i>includes 86</i>					
63★	112600	WASHER, lock, spring	4				
64★	112599	SCREW, cap, socket head	4				
68	244240	HOSE, coupled, <i>includes 69</i>	1				
69	241920	DEFLECTOR, threaded	1				
70	16X821	BOX, control	1				
75	16X981	LABEL, ProConnect	1				
76	114678	BUSHING, strain relief	1				
79★	16X203	CLIP, drain line	1				
81	288420	GUN, contractor, RAC X, packaged, 7900	1				
	241705	GUN, spray, texture, 7900HD	1				
82	189920	STRAINER, (1-11 1/2 NPSM)	1				
86		FITTING, pump					
	16Y579	7900	1				
	16X835	TexSpray 7900HD	1				
87		HOSE, coupled					
	16X904	7900	1				
	16X905	TexSpray 7900HD	1				
89	248215	TUBE, intake, <i>includes 90</i>	1				

▲ Replacement Danger and Warning Labels, Tags and Cards are available at no cost.

† Included in Clutch Replacement Kit 241113.

★ Included in bearing housing kit 24V089

Part Specifications:

Ref.	Instruction
12	Inflate tires to 28-32 psi (1.93-2.21 bar/0.193-0.221 MPa)
23	Torque clamp adjustment bolt to 140-160 in-lb (15.8-18.1 N•m) with reference 47 installed and ProConnect in locked position.
24	Torque to 38-42 ft-lb (51.5-56.9 N•m)
25	Torque to 120-130 in-lb (13.4-14.7 N•m)
26	Torque to 40-45 in-lb (4.5-5.1 N•m)
27	Torque to 17-23 ft-lb (23.1-31.2 N•m)
28	Torque to 190-210 in-lb (21.5-23.7 N•m)
29	Torque to 115-135 in-lb (12.9-15.3 N•m)
30	Torque to 23-29 ft-lb (31.2-39.2 N•m)
31	Torque to 130-150 in-lb (14.7-16.9 N•m)

Ref.	Instruction
32	Torque to 30-45in-lb (3.4-5.1 N•m)
33	Torque to 90-110 in-lb (10.2-12.4 N•m)
35	Torque to 8-12 in-lb (0.9-1.4 N•m)
37	Torque to 70-90 in-lb (7.9-10.2 N•m)
43	Torque to 170-190 in-lb (19.2-21.5 N•m)
45	Torque to 200-230 in-lb (22.6-25.9 N•m)

GMAX II 7900/TexSpray 7900 IronMan

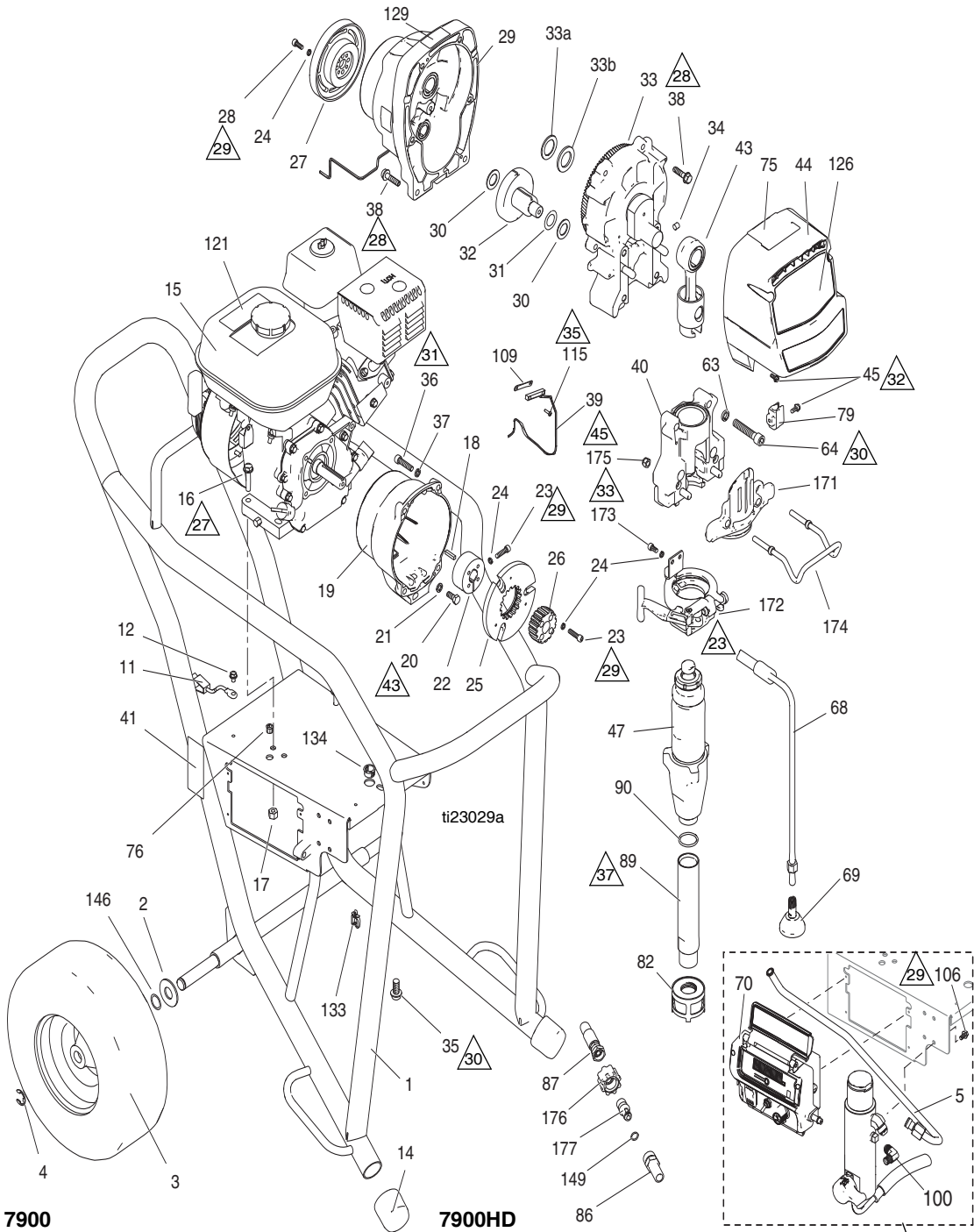

7900

7900HD

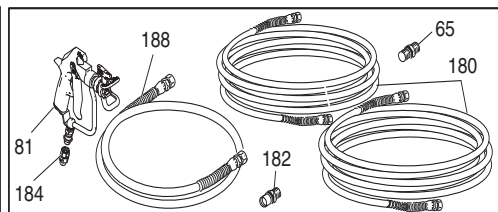
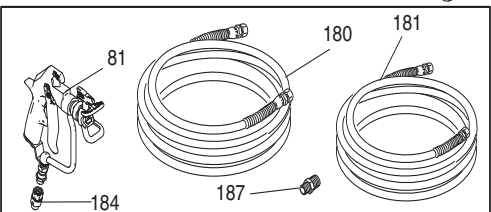

See pages 38 and 43.

Parts List - GMAX II 7900/TexSpray 7900HD IronMan

Ref.	Part	Description	Qty.	Ref.	Part	Description	Qty.
1	16X778	FRAME	1	100	125926	FITTING, 90 deg	1
2	156306	WASHER, flat	2	106	113161	SCREW, flange, hex hd	3
3	122267	WHEEL, foam	2	109	15F947	SHIELD, magnetic	1
4	120211	CLIP, retaining	2	115	114528	SCREW, mach, phillips, pnhd	2
11	237686	WIRE, ground assembly w/ clamp	1	121▲	194126	LABEL, warning	1
12	112798	SCREW, thread forming, hex hd	1	126	16X350	LABEL, identification, 7900	1
14	15C871	CAP, leg	2		16X355	LABEL, identification, TexSpray 7900	1
15	116080	ENGINE, gas, 6.5 HP, Honda	1	129	290228	LABEL, caution	1
16	110837	SCREW, flange, hex	2	133	114687	CLIP, retainer	1
17	110838	NUT, lock	2	134	119569	BUSHING, strain relief	1
18	183401	KEY, parallel	1	143	15F354	FUNNEL, oil (not shown)	1
19	15E277	HOUSING, clutch, mach, 5900/7900	1	146	116038	WASHER, wave spring	2
20	108842	SCREW, cap, hex hd	4	149		O-RING	
21	100214	WASHER, lock	4		107505	7900	1
22	193680	COLLAR, shaft	1		102982	TexSpray 7900HD	1
23†	108803	SCREW, hex, socket head	6	171★	16X209	PLATE, front, ProConnect II	1
24†	105510	WASHER, lock, spring	12	172★	16X324	CLAMP, pump, large	1
25†		ARMATURE, clutch, 5 in.	1	173★	101550	SCREW, cap, sch	2
26†		HUB, armature	1	174★	16C457	HANGER, pail	1
27†		ROTOR, clutch, 5 in.	1	175★	112746	NUT, lock, nylon, thin pattern	2
28†	101682	SCREW, cap, sch	4	176	120583	NUT, hand, 7900 only	1
29	287466	HOUSING, pinion, 7900	1	177	16X833	FITTING, quick disconnect, 3/8 npsm, 7900 only	1
30	114672	WASHER, thrust	2	180	240797	HOSE, coupled, 3/8 in. x 50 ft, 7900	1
31	114699	WASHER, thrust	1		240797	HOSE, coupled, 3/8 in. x 50 ft, 7900HD	2
32	287459	GEAR, combination, 7900	1	181	240794	HOSE, coupled, 1/4 in. x 50 ft	1
33	287470	HOUSING, drive, 7900, <i>includes 33a, 33b</i>	1	182	159841	BUSHING, 7250 psi, 3/8 in. x 1/4 in.	1
33a	116192	WASHER, thrust	1	184	189018	SWIVEL, assembly	1
33b	194173	WASHER	1	187	164672	ADAPTER	1
34	116618	MAGNET	1	188	241735	HOSE, cpld, 1/4 in. x 3 ft	1
35	112395	SCREW, cap, flng hd	1	▲	16Y631	LABEL, warning	1
36	102962	SCREW, cap sch	4	▲	16Y632	LABEL, warning	1
37	104008	WASHER, lock, spring	4	▲	16Y633	LABEL, warning	1
38	15C753	SCREW, mach, hex wash hd	6				
39	119562	SWITCH, reed w/connector	1				
40★		HOUSING, bearing, 7900	1				
41▲	15F638	LABEL, GMAX warning fire & skin	1				
43	24V086	ROD, connecting, 7900	1				
44	16Y749	COVER, front, 7900, <i>includes 45</i>	1				
45★	118444	SCREW, mach, slot hex wash hd	5				
47	16X426	PUMP, displacement, 7900, <i>includes 86, 89, 90</i>	1				
	16X427	PUMP, displacement, 7900HD, <i>includes 86</i>					
63★	112600	WASHER, lock, spring	4				
64★	112599	SCREW, cap, socket head	4				
65	162485	ADAPTER, nipple (7900HD)	1				
68	244240	HOSE, coupled, <i>includes 69</i>	1				
69	241920	DEFLECTOR, threaded	1				
70	16X821	BOX, control	1				
75	16X982	LABEL, IronMan series	1				
76	114678	BUSHING, strain relief	1				
79★	16X203	CLIP, drain line	1				
81	24A139	GUN, silver, RAC X, packaged, 7900	1				
	241705	GUN, spray, texture, 7900HD	1				
82	15V573	STRAINER, (1-11 1/2 NPSM)	1				
86		FITTING, pump					
	16Y579	7900	1				
	16X835	TexSpray 7900HD	1				
87		HOSE, coupled					
	16X904	7900	1				
	16X905	TexSpray 7900HD	1				
89	248215	TUBE, intake, <i>includes 90</i>	1				
90	118494	PACKING, o-ring, 7900	1				

▲ Replacement Danger and Warning Labels, Tags and Cards are available at no cost.

† Included in Clutch Replacement Kit 241113.

★ Included in bearing housing kit 24V089

Part Specifications:

Ref.	Instruction
▲23	Torque clamp adjustment bolt to 140-160 in-lb (15.8-18.1 N•m) with reference 47 installed and ProConnect in locked position.
▲27	Torque to 17-23 ft-lb (23.1-31.2 N•m)
▲28	Torque to 190-210 in-lb (21.5-23.7 N•m)
▲29	Torque to 115-135 in-lb (12.9-15.3 N•m)
▲30	Torque to 23-29 ft-lb (31.2-39.3 N•m)
▲31	Torque to 130-150 in-lb (14.7-16.9 N•m)
▲32	Torque to 30-45 in-lb (3.4-5.1 N•m)
▲33	Torque to 90-110 in-lb (10.2-12.4 N•m)
▲35	Torque to 8-12 in-lb (0.9-1.4 N•m)
▲37	Torque to 70-90 in-lb (7.9-10.2 N•m)
▲43	Torque to 170-190 in-lb (19.2-21.5 N•m)
▲45	Torque to 200-230 in-lb (22.5-25.9 N•m)

GMAX II 7900 Lo-Boy

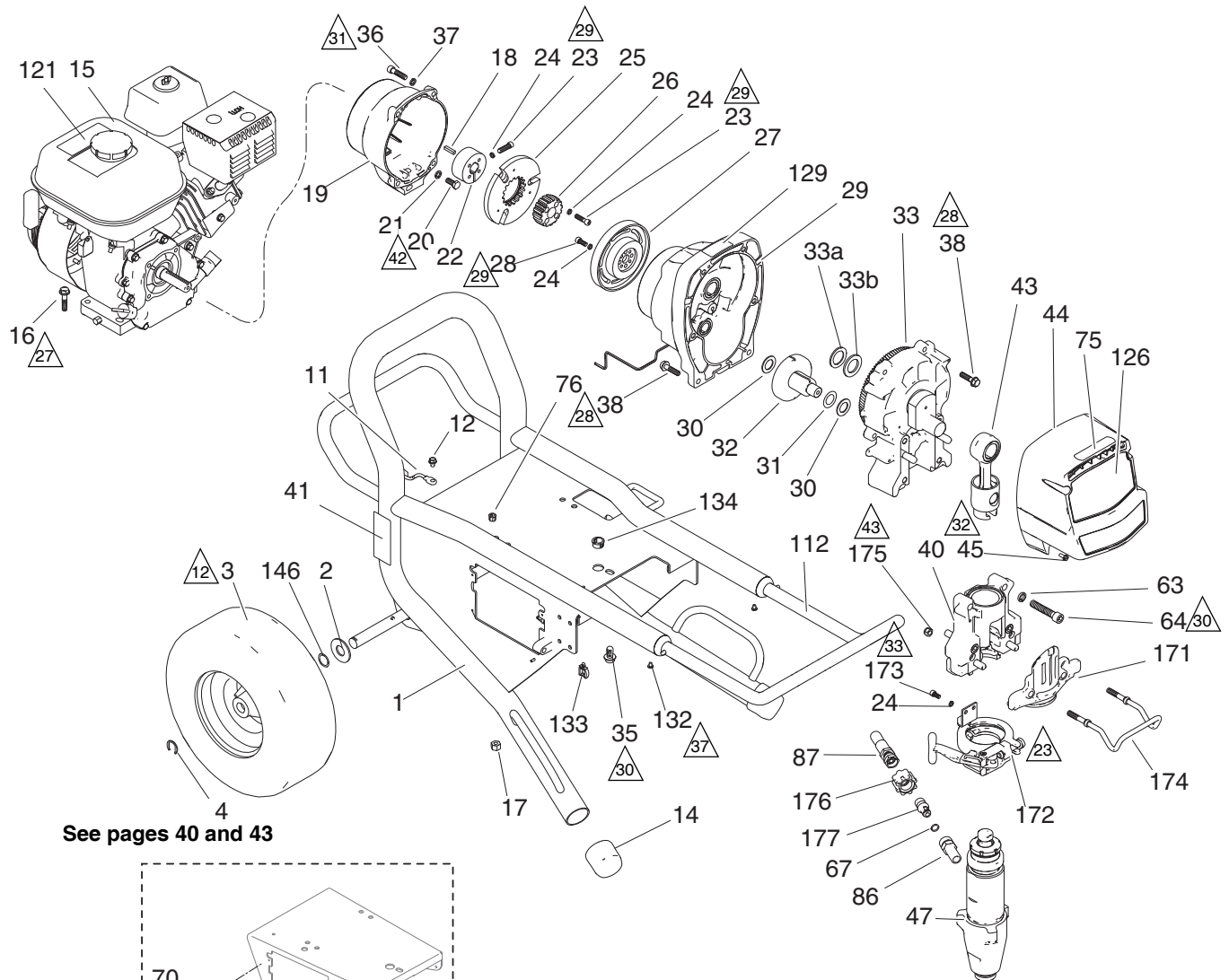

See pages 40 and 43

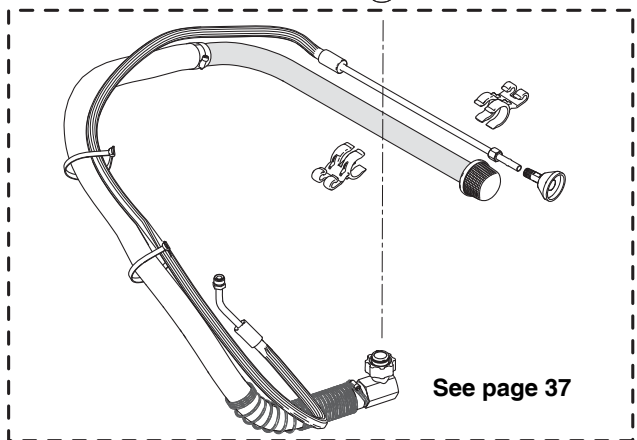
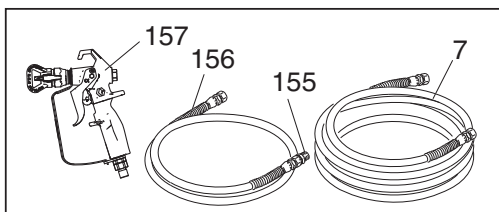
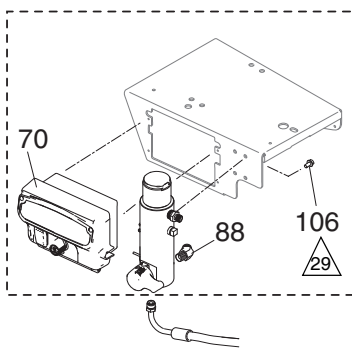

See page 37

ti23027a

Parts List - GMAX II 7900/Lo-Boy

Ref.	Part	Description	Qty.	Ref.	Part	Description	Qty.																
1	16Y519	FRAME	1	106	113161	SCREW, flange, hex hd	3																
2	156306	WASHER, flat	2	112	16Y780	HANDLE, cart	1																
3	119509	WHEEL, pneumatic	2	121▲	194126	LABEL, warning	1																
4	15E891	CLIP, retaining	2	126	16X350	LABEL, identification	1																
7	240797	HOSE, coupled, 3/8 in. x 50 ft	1	129	290228	LABEL, caution	1																
11	237686	WIRE, ground assembly w/ clamp	1	132	109032	SCREW, mach, pnh	4																
12	112798	SCREW, thread forming, hex hd	1	133	114687	CLIP, retainer	1																
14	276974	CAP, leg	2	134	119569	BUSHING, strain relief	1																
15	116080	ENGINE, gas, 6.5 HP, Honda	1	146	116038	WASHER, wave spring	2																
	25P296	ENGINE, gas, 6.5HP (China only)	1	155	159841	BUSHING, 7250 psi, 3/8 in. x 1/4 in.	1																
16	110837	SCREW, flange, hex	2	156	241735	HOSE, cpld, 1/4 in. x 3 ft	1																
17	110838	NUT, lock	2	157	288420	GUN, contractor, RAC X, packaged	1																
18	183401	KEY, parallel	1	171★	16X209	PLATE, front, ProConnect II, 7900	1																
19	15E277	HOUSING, clutch, 5900/7900	1	172★	16X324	CLAMP, pump, large	1																
20	108842	SCREW, cap, hex hd	4	173★	101550	SCREW, cap, sch	2																
21	100214	WASHER, lock	4	174★	16C457	HANGER, pail	1																
22	193680	COLLAR, shaft	1	175★	112746	NUT, lock, nylon, thin pattern	2																
23†	108803	SCREW, hex, socket head	6	176	120583	NUT, hand	1																
24†	105510	WASHER, lock, spring	12	177	16X833	FITTING, quick disconnect, 3/8 npsm	1																
25†		ARMATURE, clutch, 5 in.	1	▲	16Y631	LABEL, warning	1																
26†		HUB, armature	1	▲	16Y632	LABEL, warning	1																
27†		ROTOR, clutch, 5 in.	1	▲	16Y633	LABEL, warning	1																
28†	101682	SCREW, cap, sch	4	▲ Replacement Danger and Warning Labels, Tags and Cards are available at no cost.																			
29	287466	HOUSING, pinion, 7900	1	† Included in Clutch Replacement Kit 241113.																			
30	114672	WASHER, thrust	2	Suction Kit 16Y760 Kit is available																			
31	114699	WASHER, thrust	1	★ Included in bearing housing kit 24V089																			
32	287459	GEAR, combination, 7900	1	Part Specifications:																			
33	287470	HOUSING, drive, 7900, <i>includes 33a, 33b</i>	1	<table border="1"> <thead> <tr> <th>Ref.</th> <th>Instruction</th> </tr> </thead> <tbody> <tr> <td>▲2▲</td> <td>Inflate tires to 28-32 psi (1.93-2.21 bar/0.193-0.221 MPa)</td> </tr> <tr> <td>▲3▲</td> <td>Torque clamp adjustment bolt to 140-160 in-lb (15.8-18.1 N•m) with reference 47 installed and ProConnect in locked position.</td> </tr> <tr> <td>▲7▲</td> <td>Torque to 17-23 ft-lb (23.1-31.2 N•m)</td> </tr> <tr> <td>▲8▲</td> <td>Torque to 190-210 in-lb (21.5-23.7 N•m)</td> </tr> <tr> <td>▲9▲</td> <td>Torque to 115-135 in-lb (12.9-15.3 N•m)</td> </tr> <tr> <td>▲0▲</td> <td>Torque to 23-29 ft-lb (31.2-39.3 N•m)</td> </tr> <tr> <td>▲1▲</td> <td>Torque to 130-150 in-lb (14.7-16.9 N•m)</td> </tr> </tbody> </table>				Ref.	Instruction	▲2▲	Inflate tires to 28-32 psi (1.93-2.21 bar/0.193-0.221 MPa)	▲3▲	Torque clamp adjustment bolt to 140-160 in-lb (15.8-18.1 N•m) with reference 47 installed and ProConnect in locked position.	▲7▲	Torque to 17-23 ft-lb (23.1-31.2 N•m)	▲8▲	Torque to 190-210 in-lb (21.5-23.7 N•m)	▲9▲	Torque to 115-135 in-lb (12.9-15.3 N•m)	▲0▲	Torque to 23-29 ft-lb (31.2-39.3 N•m)	▲1▲	Torque to 130-150 in-lb (14.7-16.9 N•m)
Ref.	Instruction																						
▲2▲	Inflate tires to 28-32 psi (1.93-2.21 bar/0.193-0.221 MPa)																						
▲3▲	Torque clamp adjustment bolt to 140-160 in-lb (15.8-18.1 N•m) with reference 47 installed and ProConnect in locked position.																						
▲7▲	Torque to 17-23 ft-lb (23.1-31.2 N•m)																						
▲8▲	Torque to 190-210 in-lb (21.5-23.7 N•m)																						
▲9▲	Torque to 115-135 in-lb (12.9-15.3 N•m)																						
▲0▲	Torque to 23-29 ft-lb (31.2-39.3 N•m)																						
▲1▲	Torque to 130-150 in-lb (14.7-16.9 N•m)																						
33a	116192	WASHER, thrust	1																				
33b	194173	WASHER	1																				
35	112395	SCREW, cap, flng hd	1																				
36	102962	SCREW, cap sch	4																				
37	104008	WASHER, lock, spring	4																				
38	15C753	SCREW, mach, hex wash hd	6																				
40★		HOUSING, bearing	1																				
41▲	15F638	LABEL, GMAX warning fire & skin	1																				
43	24V086	ROD, connecting, 7900	1																				
44	16Y749	COVER, front, 7900, <i>includes 45</i>	1																				
45★	118444	SCREW, mach, slot hex wash hd	4																				
47	16X426	PUMP, displacement, 7900, <i>includes 86, 89, 90</i>	1																				
63★	112600	WASHER, lock, spring	4																				
64★	112599	SCREW, cap, socket head	4																				
67	107505	O-RING	1																				
70	16X822	BOX, control	1																				
75	16X979	LABEL, Proconnect	1																				
76	114678	BUSHING, strain relief	1																				
86	16Y579	FITTING, pump	1																				
87	16X950	HOSE, coupled	1																				
88	122533	FITTING, 45 deg	1																				

Ref.	Instruction
32	Torque to 30-45 in-lb (3.4-5.1 N•m)
33	Torque to 90-110 in-lb (10.2-12.4 N•m)
37	Torque to 25-35 in-lb (2.8-3.9 N•m)
42	Torque to 170-190 in-lb (19.2-25.9 N•m)
43	Torque to 200-230 in-lb (22.5-25.9 N•m)

LoBoy Suction Set Kits

(Kits include suction set and drain hose)

GMAX II 3900/5900/7900

5 Gallon Kit: 16Y759 (included with 3900 and 5900)

30 - 55 Gallon Kit: 16Y760 (included with 7900)

Ref.	Part	Description	Qty.
509	24W028	HOSE, suction 5 gallon, <i>includes 510, 511, 512, 514, 557, 558, 559, 561</i>	1
	24U917	HOSE, suction 30 - 55 gallon, <i>includes 510, 511, 512, 514, 557, 558, 559, 561</i>	1
510	15C980	NUT, jam	1
511	15H854	O-RING	2
512	15C981	WASHER, suction, swivel	1
514	118505	RING, retaining, external	1
515	15D000	CLIP, drain line	2
555	241920	DEFLECTOR	1
556		HOSE, drain, <i>includes 555</i>	
	288732	5 gallon	1
	246331	30 - 55 gallon	1
557		TUBE, suction	
	15D157	5 gallon	1
	15F171	30 - 50 gallon	1
558	24A561	FITTING, elbow, barbed, <i>includes 510, 512, 514</i>	1
559	120330	CLAMP, hose	2
561	176450	GUARD, hose	1
582	189920	STRAINER, 1-11 1/2 npsm	1
586		Washer	1
	115099	3900/5900	
	119566	7900	
591		TIE STRAP	2

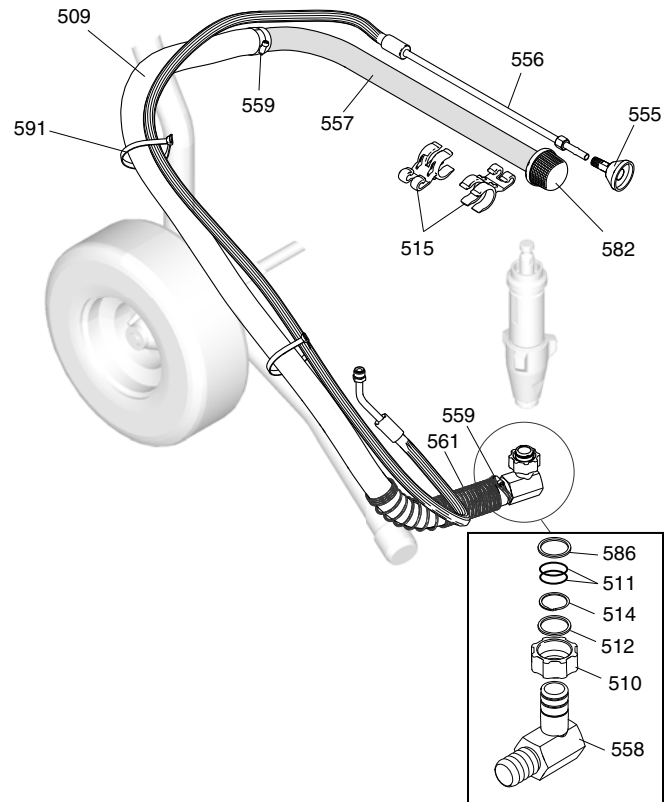

Control Box 16X821

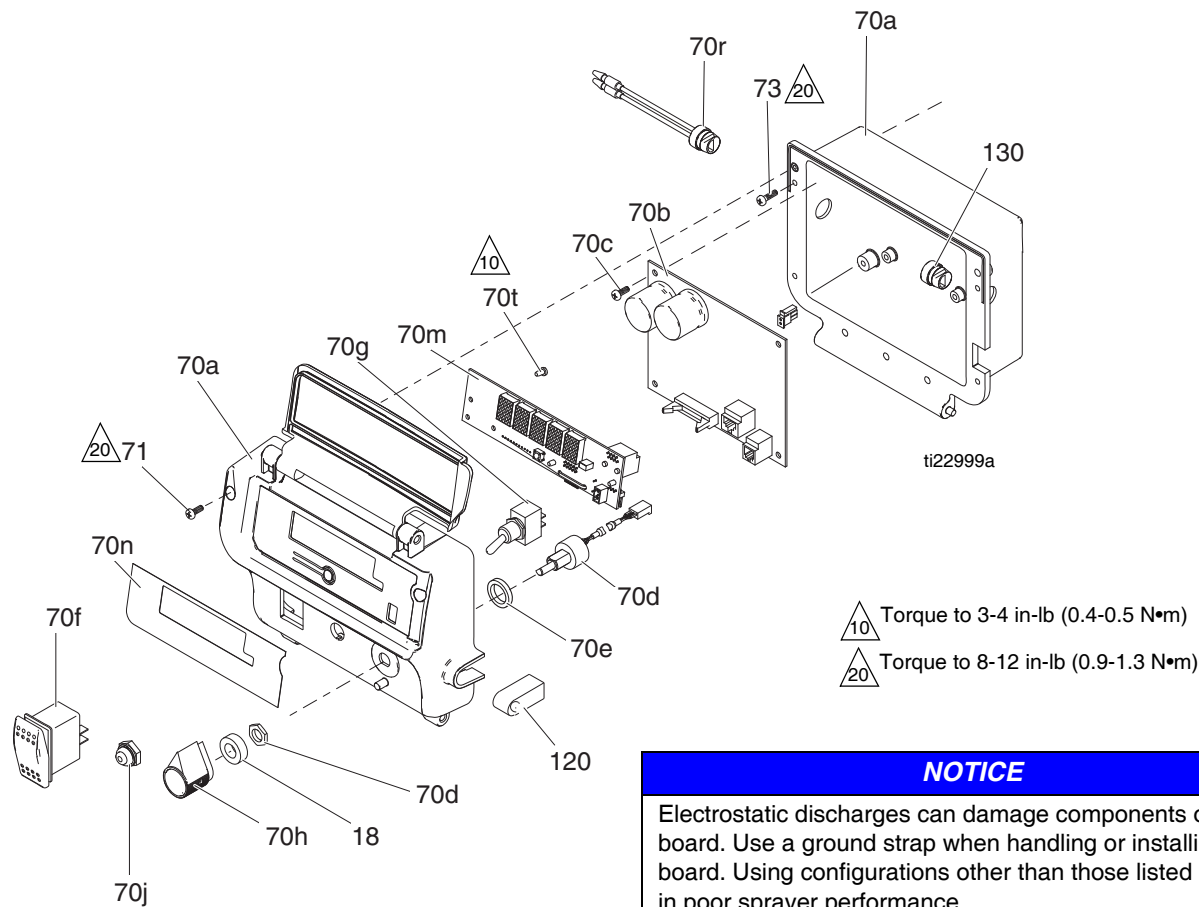

- Torque to 3-4 in-lb (0.4-0.5 N•m)
- Torque to 8-12 in-lb (0.9-1.3 N•m)

NOTICE

Electrostatic discharges can damage components on PC board. Use a ground strap when handling or installing PC board. Using configurations other than those listed results in poor sprayer performance.

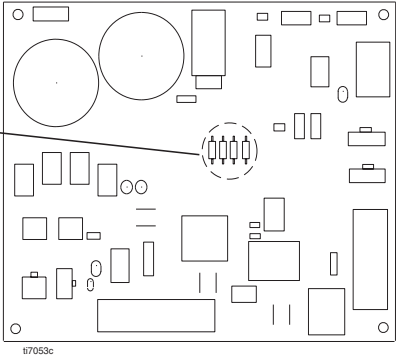
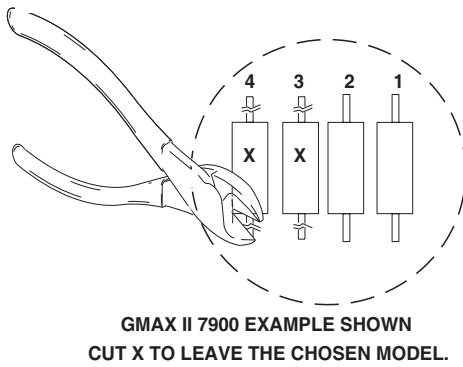

- 1 Refer to your sprayer repair manual for the procedures.
- 2 Perform **Pressure Relief Procedure**.
- 3 Remove pressure control cover.
- 4 Remove PC board.
- 5 Cut out and remove the resistor(s) on PC board according to figure and table.
- 6 Install PC board.
- 7 Install pressure control cover.

	3900		5900			7900	
	GMAX II 3900	International GMAX II 3900	GMAX II 5900/5900HD	GMAX II 5900/5900HD International	GMAX II 5900 Convertible	GMAX II 7900/7900HD	GMAX II 7900/7900HD International
1	x	x					x
2			x	x			
3		x	x			x	x
4				x	x	x	x

Parts List - Control Box 16X821

Ref.	Part	Description	Qty.	Ref.	Part	Description	Qty.
18	15C973	GASKET	1	70j	195428	BOOT, toggle	1
70	16X821	CONTROL BOX		70m	16Y496	KIT, display, <i>includes 70t</i>	1
70a	24U347	BOX	1	70n	16X801	LABEL, brand	1
70b	17A095	CONTROL, board	1	70r	119545	BUSHING, strain, relief	1
70c	117317	SCREW, plastite, pan head	4	70t	115522	SCREW, mach, pnh	3
70d	256219	POTENTIOMETER	1	71	116585	SCREW, pan, X recess, sst	2
70f	116752	SWITCH, rocker	1	73	113160	SCREW, mach, slot, hex wash hd	4
70e	198650	SPACER, shaft	1				
70g	119541	SWITCH, toggle	1	120	16Y415	GASKET, transducer	1
70h	116167	KNOB, potentiometer	1	130	119545	BUSHING, strain, relief	1

Control Box 16X822

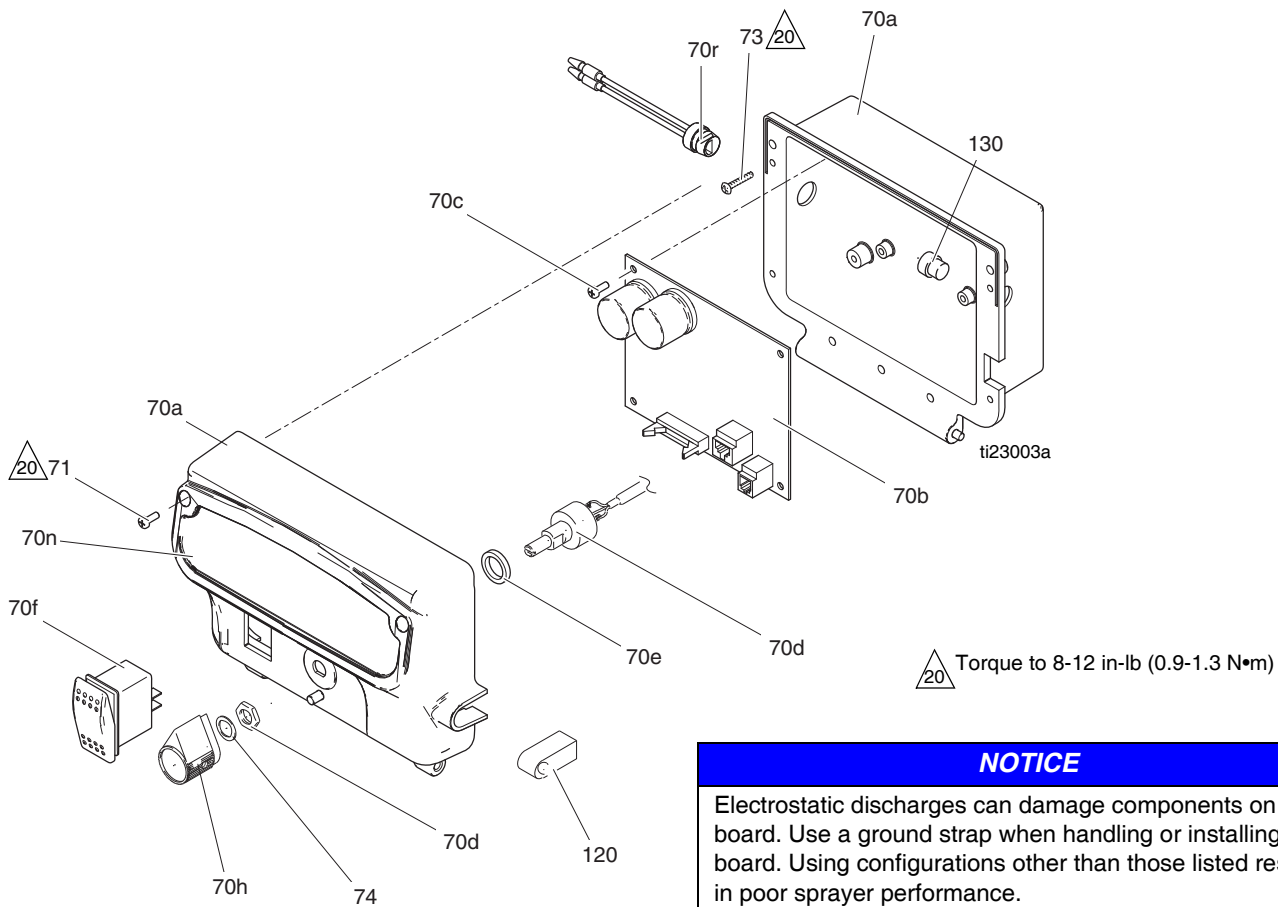

NOTICE
 Electrostatic discharges can damage components on PC board. Use a ground strap when handling or installing PC board. Using configurations other than those listed results in poor sprayer performance.

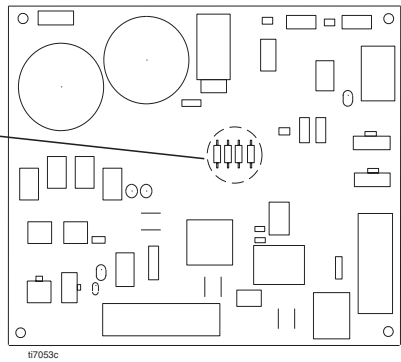
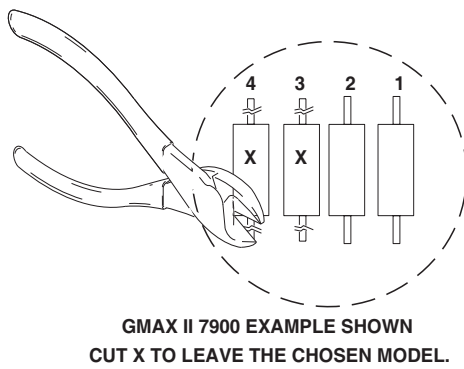

- 1 Refer to your sprayer repair manual for the procedures.
- 2 Perform **Pressure Relief Procedure**.
- 3 Remove pressure control cover.
- 4 Remove PC board.
- 5 Cut out and remove the resistor(s) on PC board according to figure and table.
- 6 Install PC board.
- 7 Install pressure control cover.

	3900		5900			7900	
	GMAX II 3900	International GMAX II 3900	GMAX II 5900/5900HD	GMAX II 5900/5900HD International	GMAX II 5900 Convertible	GMAX II 7900/7900HD	GMAX II 7900/7900HD International
1	X	X					X
2			X	X			
3		X	X			X	X
4				X	X	X	X

Parts List - Control Box 16X822

Ref.	Part	Description	Qty.	Ref.	Part	Description	Qty.
70	16X822	CONTROL BOX		70r	119545	BUSHING, strain, relief	1
70a	24U346	BOX	1	71	116585	SCREW, pan, X recess, sst	2
70b	17A095	CONTROL, board	1	73	116585	SCREW, pan, X recess, sst (5900 Convertible)	4
70c	117317	SCREW, plastite, pan head	4		113160	SCREW, mach, slot, hex wash hd	4
70d	256219	POTENTIOMETER	1				
70e	198650	SPACER, shaft	1	74	15C973	GASKET	1
70f	116752	SWITCH, rocker	1	120	16Y415	GASKET, transducer	1
70h	116167	KNOB, potentiometer	1	130	119545	BUSHING, strain, relief	1
70n	16Y782	LABEL, brand	1				

Control Box 25P549

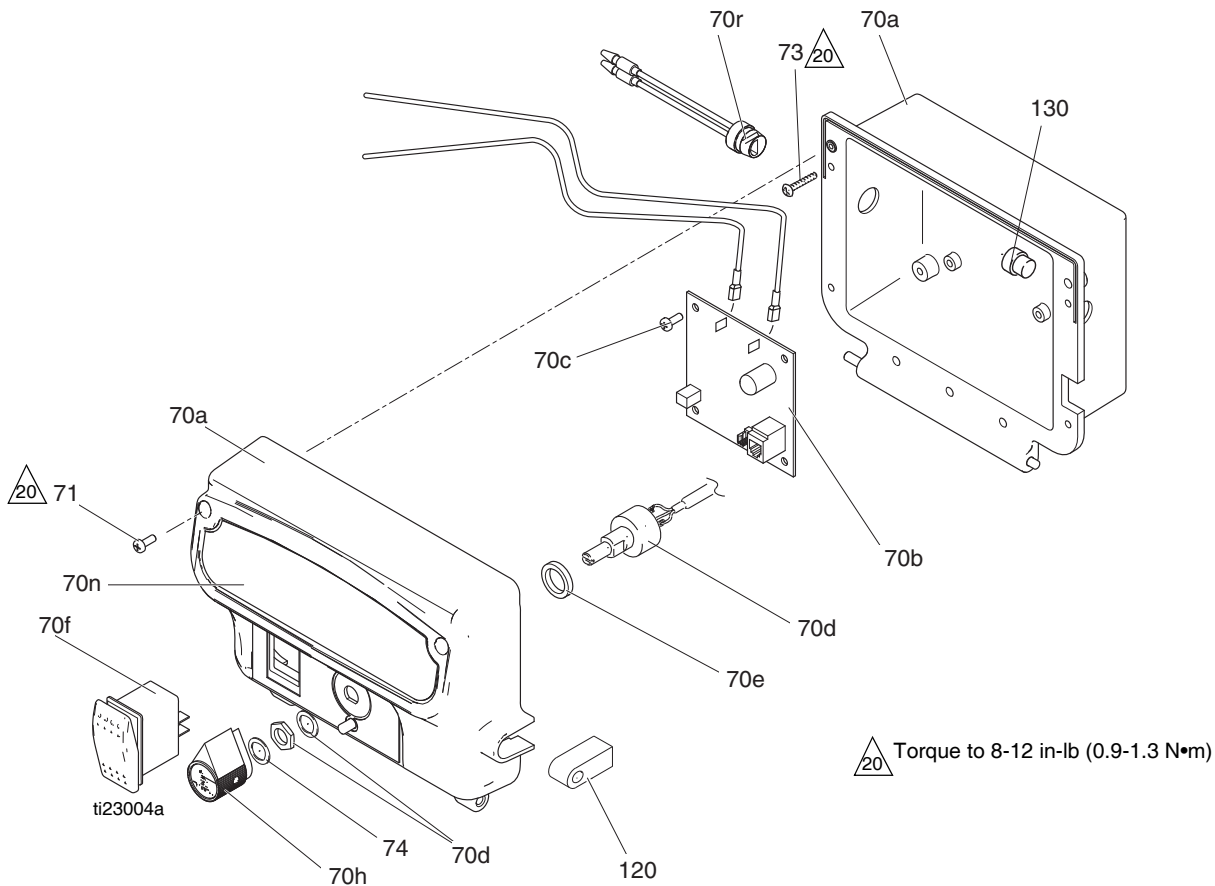

Parts List - Control Box 25P549

Ref.	Part	Description	Qty.	Ref.	Part	Description	Qty.
70	25P549	CONTROL BOX, GMAX 3400		70r	119545	BUSHING, strain, relief	1
70a	24U346	BOX	1	71	116585	SCREW, pan, X recess, sst	2
70b	25P550	KIT, repair, control board	1	73	116585	SCREW, pan, X recess, sst (5900 Convertible)	4
70c	117317	SCREW, plastite, pan head	4		113160	SCREW, mach, slot, hex wash hd	4
70d	256219	POTENTIOMETER	1	74	15C973	GASKET	1
70e	198650	SPACER, shaft	1	120	16Y415	GASKET, transducer	1
70f	116752	SWITCH, rocker	1	130	119545	BUSHING, strain, relief	1
70h	116167	KNOB, potentiometer	1				
70n	16Y782	LABEL, brand	1				

Filter

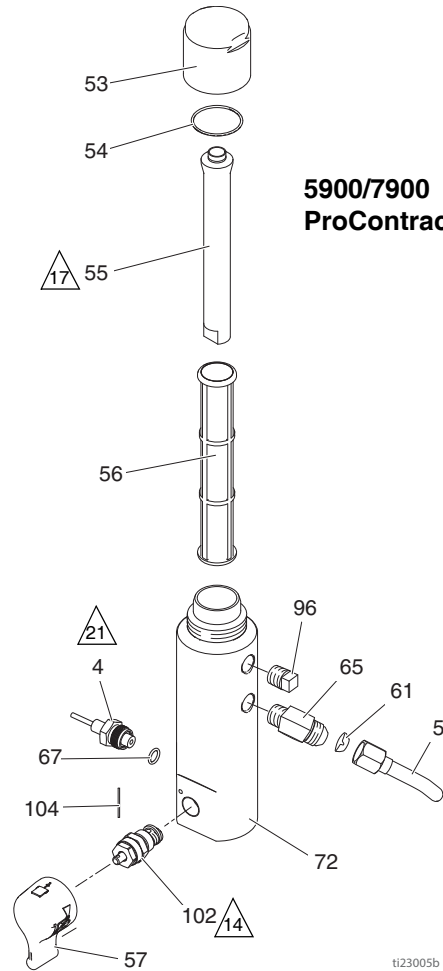
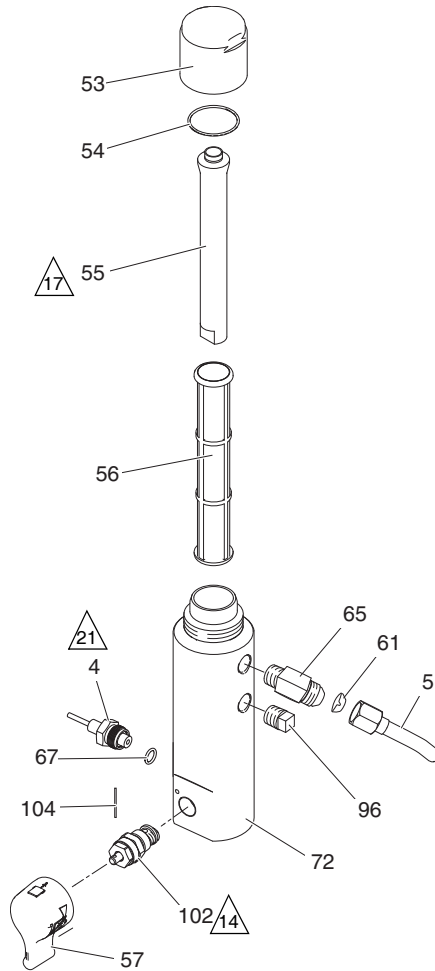

**5900/7900
ProContractor Only**

t123005b

Parts List - Filter

Ref.	Part	Description	Qty.
4	243222	TRANSDUCER, pressure control <i>includes 63</i>	1
5	16C381	TUBE, GMAX 5900/7900 (ProContractor)	1
	16C384	TUBE, GMAX 3900 (ProContractor)	1
53	287285	CAP, filter, <i>includes 54, 55</i>	1
54	117285	PACKING, o-ring	1
55	15C766	TUBE, diffusion	1
56	244067	FILTER, fluid	1
57	24E234	KIT, handle 2 position	1
61	123739	SEAL, fitting, flared	1
65	122533	FITTING, 45 deg elbow (ProConnect)	1
	162485	FITTING, adapter (7900, IronMan)	1
	196177	FITTING, adapter (3900/5900 Standard, Convertible and Lo-Boy)	1
	196178	FITTING, adapter (5900 IronMan/ 7900 Standard/5900HD/7900HD Standard)	1

Ref.	Part	Description	Qty.
67	111457	PACKING, o-ring	1
72	15E284	HOUSING, filter	1
96	15G331	PLUG, pipe	1
102	257352	VALVE, prime, heavy duty, <i>includes 57, 104</i>	1
104	15C972	PIN, spring	1

Part Specifications:

Ref.	Instruction
△4	Torque to 130-150 in-lb (14.6-16.9 N•m)
△17	Torque to 90-110 in-lb (10.1-12.4 N•m)
△21	Torque to 35-45 ft-lb (47.4-61.0 N•m)

Filter (3400 Models only)

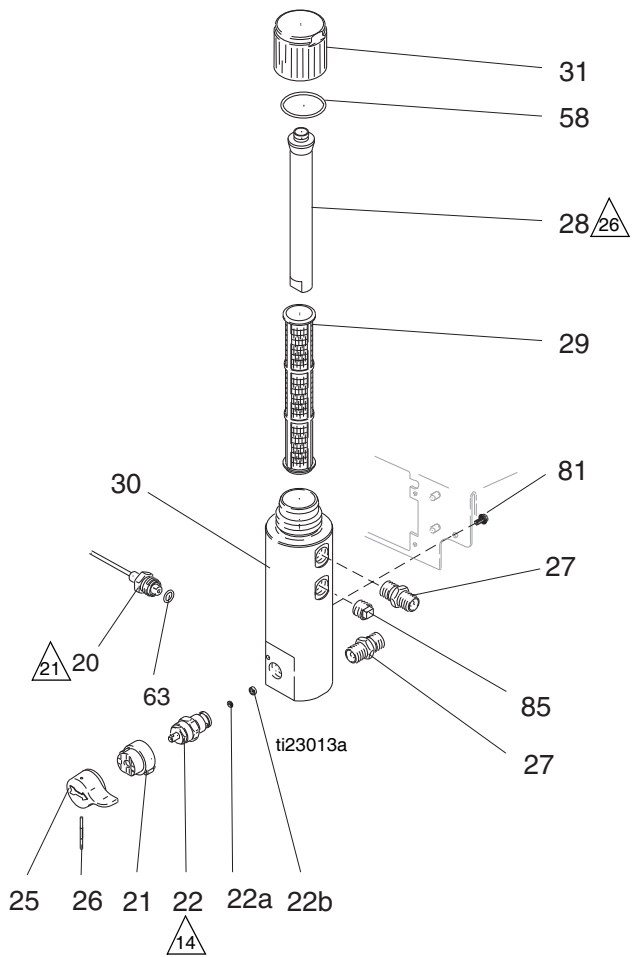

Parts List - Filter

Ref.	Part	Description	Qty.
20	243222	TRANSDUCER, pressure control, includes 63	1
21	224807	BASE, valve	1
22	235014	VALVE, drain, includes 22a, 22b	1
25	15C780	HANDLE,	1
26	15C972	PIN, grooved	1
27	196177	NIPPLE, adapter	2
28	15C766	TUBE, diffusion	1
29	244067	FILTER, fluid	1
30	15E284	HOUSING, filter	1

Ref.	Part	Description	Qty.
31	287285	CAP, filter, includes 28, 58	1
58	117285	O-RING	1
63	111457	O-RING	1
81	113161	SCREW, flange, hex hd	3
85	15G331	PLUG, pipe	1

Part Specifications:

Ref.	Instruction
14	Torque to 130-150 in-lb (14.6-16.9 N•m)
21	Torque to 35-45 ft-lb (47.4-61.0 N•m)
26	Torque to 90-110 in-lb (10.1-12.4 N•m)

Hose Reel (ProContractor Sprayers)

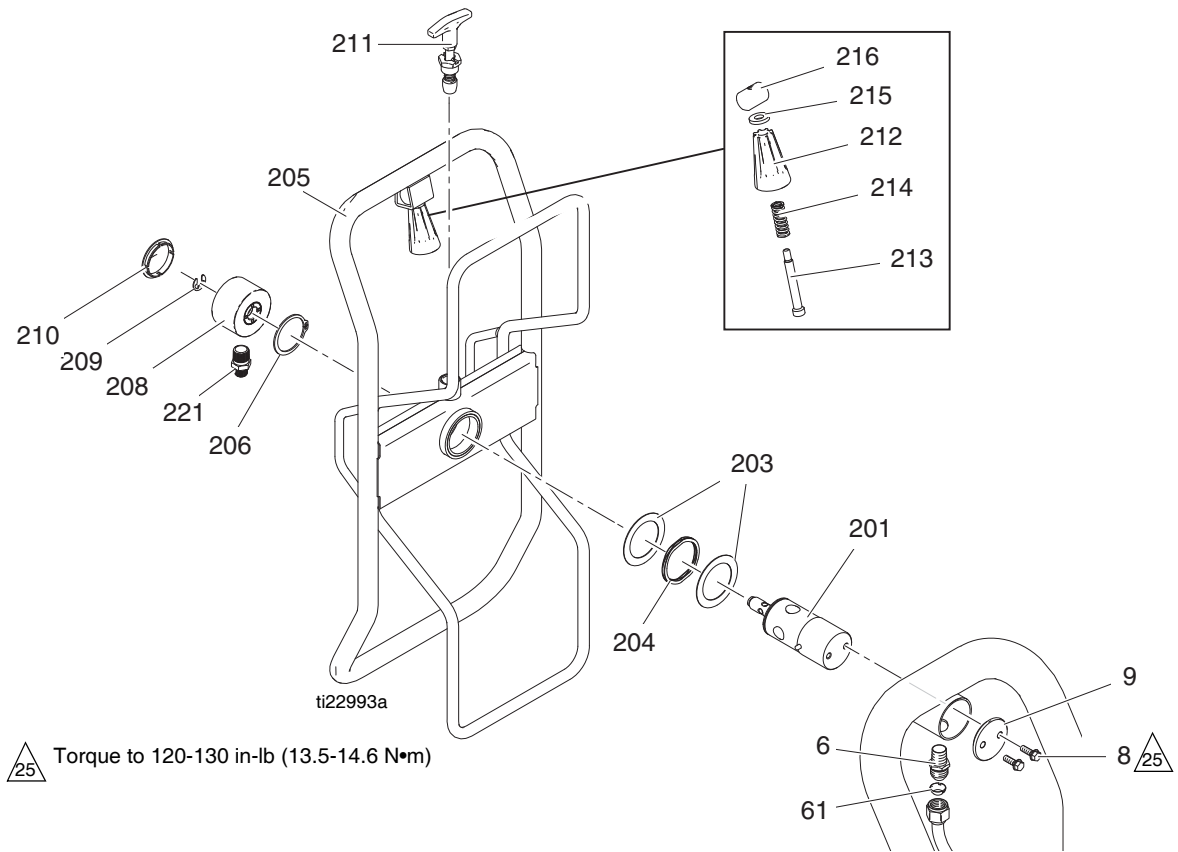

Parts List - Hose Reel (ProContractor Sprayers)

Ref.	Part	Description	Qty.	Ref.	Part	Description	Qty.
6	121311	FITTING, connector, NPT x JIC	1	209	122347	RING, retaining, external	1
8	260212	SCREW, hex washer hd	2	210	122787	CAP	1
9	16C975	PLATE, pivot mount	1	211	24E400	PIN, pop, lock out	1
61	123739	SEAL, fitting, flared	1	212	278085	HANDLE, swivel	1
201	24E016	TUBE, hose reel, pivot	1	213	122518	SCREW, shoulder, sch	1
203	122607	WASHER, flat	2	214	122542	SPRING, die	1
204	122534	SPRING, wave	1	215	122669	WASHER, flat	1
205	24B691	REEL, hose	1	216	15X618	NUT, swivel, handle	1
206	122524	RING, retaining, external	1	221	164672	ADAPTER	1
208	24B248	CAP, swivel, complete	1		162485	ADAPTER	1
						(3900/5900 ProContractor only)	

Pressure Control Wiring Diagrams

GMAX 3400 Sprayers

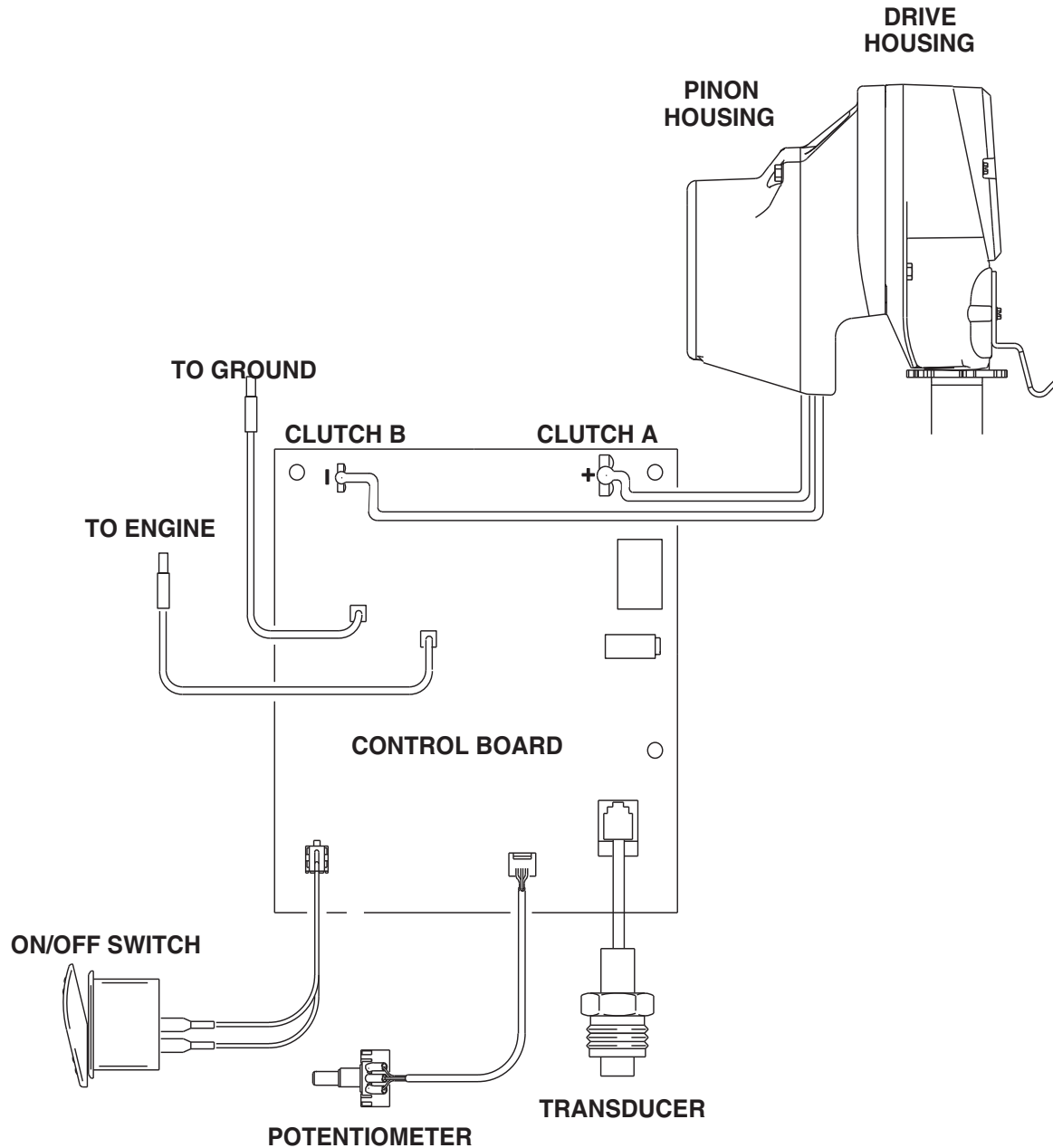

All written and visual data contained in this document reflects the latest product information available at the time of publication. Graco reserves the right to make changes at any time without notice.

Original instructions. This manual contains English. MM 332921

Graco Headquarters: Minneapolis
International Offices: Belgium, China, Japan, Korea

GRACO INC. AND SUBSIDIARIES • P.O. BOX 1441 • MINNEAPOLIS MN 55440-1441 • USA

Copyright 2014, Graco Inc. All Graco manufacturing locations are registered to ISO 9001.

www.graco.com

Revision K, December 2019

3900/5900/7900 Sprayers

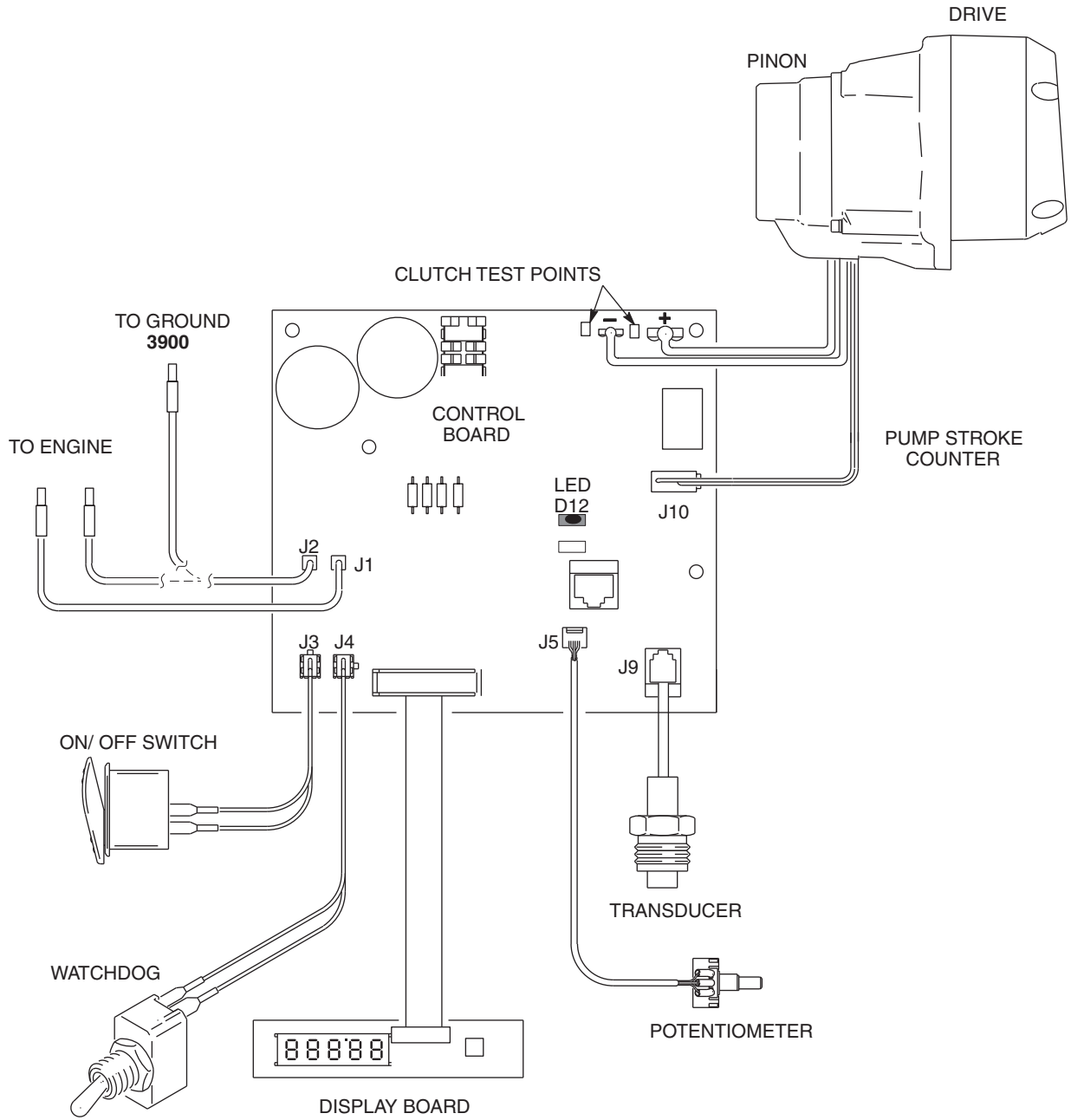

Graco Standard Warranty

Graco warrants all equipment referenced in this document which is manufactured by Graco and bearing its name to be free from defects in material and workmanship on the date of sale to the original purchaser for use. With the exception of any special, extended, or limited warranty published by Graco, Graco will, for a period of twelve months from the date of sale, repair or replace any part of the equipment determined by Graco to be defective. This warranty applies only when the equipment is installed, operated and maintained in accordance with Graco's written recommendations.

This warranty does not cover, and Graco shall not be liable for general wear and tear, or any malfunction, damage or wear caused by faulty installation, misapplication, abrasion, corrosion, inadequate or improper maintenance, negligence, accident, tampering, or substitution of non-Graco component parts. Nor shall Graco be liable for malfunction, damage or wear caused by the incompatibility of Graco equipment with structures, accessories, equipment or materials not supplied by Graco, or the improper design, manufacture, installation, operation or maintenance of structures, accessories, equipment or materials not supplied by Graco.

This warranty is conditioned upon the prepaid return of the equipment claimed to be defective to an authorized Graco distributor for verification of the claimed defect. If the claimed defect is verified, Graco will repair or replace free of charge any defective parts. The equipment will be returned to the original purchaser transportation prepaid. If inspection of the equipment does not disclose any defect in material or workmanship, repairs will be made at a reasonable charge, which charges may include the costs of parts, labor, and transportation.

THIS WARRANTY IS EXCLUSIVE, AND IS IN LIEU OF ANY OTHER WARRANTIES, EXPRESS OR IMPLIED, INCLUDING BUT NOT LIMITED TO WARRANTY OF MERCHANTABILITY OR WARRANTY OF FITNESS FOR A PARTICULAR PURPOSE.

Graco's sole obligation and buyer's sole remedy for any breach of warranty shall be as set forth above. The buyer agrees that no other remedy (including, but not limited to, incidental or consequential damages for lost profits, lost sales, injury to person or property, or any other incidental or consequential loss) shall be available. Any action for breach of warranty must be brought within two (2) years of the date of sale.

GRACO MAKES NO WARRANTY, AND DISCLAIMS ALL IMPLIED WARRANTIES OF MERCHANTABILITY AND FITNESS FOR A PARTICULAR PURPOSE, IN CONNECTION WITH ACCESSORIES, EQUIPMENT, MATERIALS OR COMPONENTS SOLD BUT NOT MANUFACTURED BY GRACO. These items sold, but not manufactured by Graco (such as electric motors, switches, hose, etc.), are subject to the warranty, if any, of their manufacturer. Graco will provide purchaser with reasonable assistance in making any claim for breach of these warranties.

In no event will Graco be liable for indirect, incidental, special or consequential damages resulting from Graco supplying equipment hereunder, or the furnishing, performance, or use of any products or other goods sold hereto, whether due to a breach of contract, breach of warranty, the negligence of Graco, or otherwise.

FOR GRACO CANADA CUSTOMERS

The Parties acknowledge that they have required that the present document, as well as all documents, notices and legal proceedings entered into, given or instituted pursuant hereto or relating directly or indirectly hereto, be drawn up in English. Les parties reconnaissent avoir convenu que la rédaction du présente document sera en Anglais, ainsi que tous documents, avis et procédures judiciaires exécutés, donnés ou intentés, à la suite de ou en rapport, directement ou indirectement, avec les procédures concernées.

Graco Information

For the latest information about Graco products, visit www.graco.com.

For patent information, see www.graco.com/patents.

TO PLACE AN ORDER, contact your Graco distributor or call 1-800-690-2894 to identify the nearest distributor.

All written and visual data contained in this document reflects the latest product information available at the time of publication. Graco reserves the right to make changes at any time without notice.

Original instructions. This manual contains English. MM 332921

Graco Headquarters: Minneapolis

International Offices: Belgium, China, Japan, Korea

GRACO INC. AND SUBSIDIARIES • P.O. BOX 1441 • MINNEAPOLIS MN 55440-1441 • USA

Copyright 2014, Graco Inc. All Graco manufacturing locations are registered to ISO 9001.

www.graco.com

Revision K, December 2019