

## Husky™ 1050HP 2:1 Air-Operated Diaphragm Pump

334014D  
EN

1-inch high-pressure pump with modular air valve for fluid transfer applications. For professional use only.



### Important Safety Instructions

Read all warnings and instructions in this manual and in your Repair/Parts manual. **Save these instructions.**

*Maximum Fluid Working Pressure:*  
250 psi (1.72 MPa, 17.2 bar)

*Maximum Air Input Pressure:* 125 psi  
(0.86 MPa, 8.6 bar)

*See page 4 for approvals.*

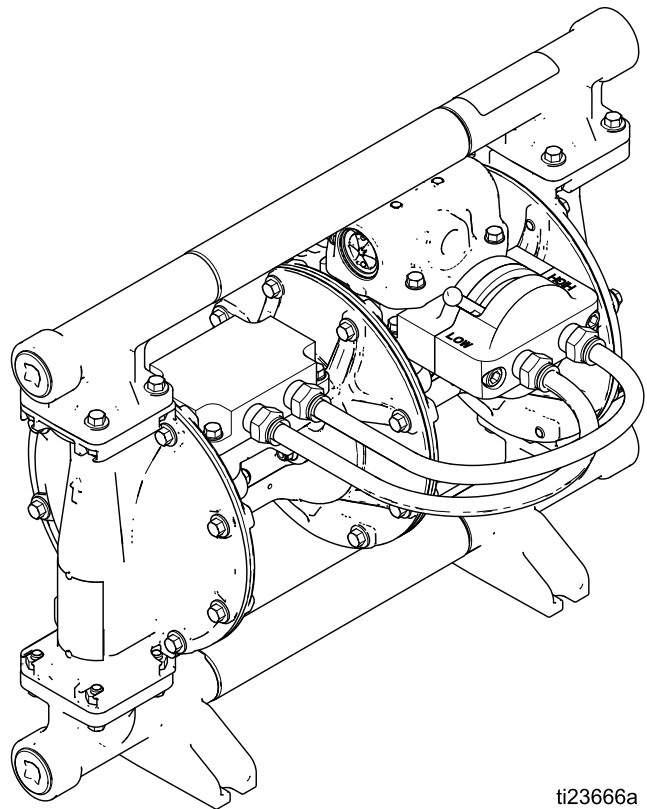

ti23666a

# Contents

Related Manuals .....	2	Tighten Fasteners Before Setup.....	13
Ordering Information.....	3	Flush the Pump Before First Use .....	13
Configuration Number Matrix.....	4	High/Low Lever.....	13
Warnings .....	5	Start and Adjust the Pump.....	14
Installation.....	8	Pump Shutdown .....	14
Tighten Fasteners Before Setup.....	8	Maintenance .....	15
Mounting .....	8	Maintenance Schedule .....	15
Grounding .....	8	Lubrication.....	15
Air Line.....	9	Tighten Threaded Connections .....	15
Air Exhaust Ventilation .....	10	Flushing and Storage .....	15
Fluid Supply Line .....	11	Torque Instructions .....	16
Fluid Outlet Line.....	11	Dimensions and Mounting.....	17
Fluid Inlet and Outlet Ports .....	11	Performance Charts.....	18
Typical Floor Mount Installation.....	12	Technical Data .....	20
Operation.....	13	Fluid Temperature Range.....	21
Pressure Relief Procedure.....	13	Graco Standard Husky Pump Warranty.....	22

## Related Manuals

Manual No.	Description
334390	Husky 1050HP Air-Operated Diaphragm Pump, Repair/Parts

**NOTE:** For Troubleshooting information, see the Repair/Parts Manual 334390.

# Ordering Information

## To Find Your Nearest Distributor

1. Visit [www.graco.com](http://www.graco.com).
2. Click on **Where to Buy** and use the **Distributor Locator**.

## To Specify the Configuration of a New Pump

Please call your distributor.

## To Order Replacement Parts

Please call your distributor.

## Distributor Note

1. To find part numbers for replacement parts:
  - a. Use the 20-digit number from the ID plate on the pump.
  - b. Use the Configuration Number Matrix on the next page to understand which parts are described by each digit.
  - c. **Use the Repair/Parts Manual.** Refer to the main Parts illustration and to the Parts/Kits Quick Reference. Follow the page references on these two pages for further ordering information, as needed.
2. Please call Graco Customer Service to order.

# Configuration Number Matrix

Check the identification plate (ID) for the 20-digit Configuration Number of your pump. Use the following matrix to define the components of your pump.

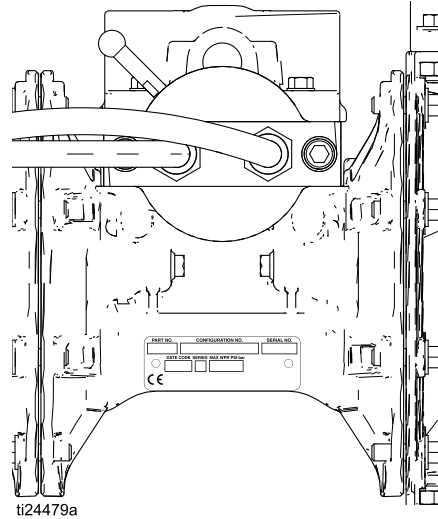

**Sample Configuration Number:**

<b>1050HP</b>	<b>A01A</b>	<b>A1</b>	<b>SS</b>	<b>SP</b>	<b>SP</b>	<b>PT</b>
Pump Model	Center Section and Air Valve	Manifolds	Seats	Balls	Diaphragms	Manifold O-Rings

Pump	Center Section and Air Valve Material		Air Valve	Manifolds	
<b>1050HP</b> Aluminum	Aluminum	<b>A01A</b>	Standard	<b>A1</b>	Aluminum, standard ports, npt
				<b>A2</b>	Aluminum, standard ports, bsp
				<b>S1</b>	Stainless steel, standard ports, npt
				<b>S2</b>	Stainless steel, standard ports, bsp

Check Valve Seats		Check Valve Balls		Diaphragm Material		Manifold O-Rings	
<b>GE</b>	Geolast®	<b>CW</b>	Polychloroprene Weighted	<b>BN</b>	Buna-N	<b>PT</b>	PTFE
<b>SP</b>	Santoprene®	<b>GE</b>	Geolast	<b>CO</b>	Polychloroprene Overmolded		
<b>SS</b>	316 Stainless Steel	<b>SP</b>	Santoprene	<b>PT</b>	PTFE/Santoprene Two-Piece		
		<b>SS</b>	316 Stainless Steel	<b>SP</b>	Santoprene		

**Approvals**







All models are rated:

















II 2 GD  
Ex h IIC 66°C...135°C Gb  
Ex h IIC T135°C Db

# Warnings

The following warnings are for the setup, use, grounding, maintenance, and repair of this equipment. The exclamation point symbol alerts you to a general warning and the hazard symbols refer to procedure-specific risks. When these symbols appear in the body of this manual or on warning labels, refer back to these Warnings. Product-specific hazard symbols and warnings not covered in this section may appear throughout the body of this manual where applicable.

 <h2 style="margin: 0;">WARNING</h2>	
   	<p><b>FIRE AND EXPLOSION HAZARD</b></p> <p>Flammable fumes, such as solvent and paint fumes, in <b>work area</b> can ignite or explode. To help prevent fire and explosion:</p> <ul style="list-style-type: none"> <li>• Use equipment only in well ventilated area.</li> <li>• Eliminate all ignition sources; such as pilot lights, cigarettes, portable electric lamps, and plastic drop cloths (potential static arc).</li> <li>• Keep work area free of debris, including solvent, rags and gasoline.</li> <li>• Do not plug or unplug power cords, or turn power or light switches on or off when flammable fumes are present.</li> <li>• Ground all equipment in the work area. See <b>Grounding</b> instructions.</li> <li>• Use only grounded hoses.</li> <li>• <b>Stop operation immediately</b> if static sparking occurs or you feel a shock. Do not use equipment until you identify and correct the problem.</li> <li>• Keep a working fire extinguisher in the work area.</li> <li>• Route exhaust away from all ignition sources. If diaphragm ruptures, fluid may be exhausted with air.</li> </ul>
 	<p><b>PRESSURIZED EQUIPMENT HAZARD</b></p> <p>Fluid from the equipment, leaks, or ruptured components can splash in the eyes or on skin and cause serious injury.</p> <ul style="list-style-type: none"> <li>• Follow the <b>Pressure Relief Procedure</b> when you stop spraying/dispensing and before cleaning, checking, or servicing equipment.</li> <li>• Tighten all fluid connections before operating the equipment.</li> <li>• Check hoses, tubes, and couplings daily. Replace worn or damaged parts immediately.</li> </ul>

 <h1 style="margin: 0;">WARNING</h1>	
 	<p><b>EQUIPMENT MISUSE HAZARD</b></p> <p>Misuse can cause death or serious injury.</p> <ul style="list-style-type: none"> <li>• Do not operate the unit when fatigued or under the influence of drugs or alcohol.</li> <li>• Do not exceed the maximum working pressure or temperature rating of the lowest rated system component. See <b>Technical Data</b> in all equipment manuals.</li> <li>• Use fluids and solvents that are compatible with equipment wetted parts. See <b>Technical Data</b> in all equipment manuals. Read fluid and solvent manufacturer's warnings. For complete information about your material, request MSDS from distributor or retailer.</li> <li>• Do not leave the work area while equipment is energized or under pressure.</li> <li>• Turn off all equipment and follow the <b>Pressure Relief Procedure</b> when equipment is not in use.</li> <li>• Check equipment daily. Repair or replace worn or damaged parts immediately with genuine manufacturer's replacement parts only.</li> <li>• Do not alter or modify equipment. Alterations or modifications may void agency approvals and create safety hazards.</li> <li>• Make sure all equipment is rated and approved for the environment in which you are using it.</li> <li>• Use equipment only for its intended purpose. Call your distributor for information.</li> <li>• Route hoses and cables away from traffic areas, sharp edges, moving parts, and hot surfaces.</li> <li>• Do not kink or over bend hoses or use hoses to pull equipment.</li> <li>• Keep children and animals away from work area.</li> <li>• Comply with all applicable safety regulations.</li> </ul>
	<p><b>PRESSURIZED ALUMINUM PARTS HAZARD</b></p> <p>Use of fluids that are incompatible with aluminum in pressurized equipment can cause serious chemical reaction and equipment rupture. Failure to follow this warning can result in death, serious injury, or property damage.</p> <ul style="list-style-type: none"> <li>• Do not use 1,1,1-trichloroethane, methylene chloride, other halogenated hydrocarbon solvents or fluids containing such solvents.</li> <li>• Do not use chlorine bleach.</li> <li>• Many other fluids may contain chemicals that can react with aluminum. Contact your material supplier for compatibility.</li> </ul>
  	<p><b>THERMAL EXPANSION HAZARD</b></p> <p>Fluids subjected to heat in confined spaces, including hoses, can create a rapid rise in pressure due to the thermal expansion. Over-pressurization can result in equipment rupture and serious injury.</p> <ul style="list-style-type: none"> <li>• Open a valve to relieve the fluid expansion during heating.</li> <li>• Replace hoses proactively at regular intervals based on your operating conditions.</li> </ul>

 <h1 style="margin: 0;">WARNING</h1>	
 	<p><b>PLASTIC PARTS CLEANING SOLVENT HAZARD</b></p> <p>Many solvents can degrade plastic parts and cause them to fail, which could cause serious injury or property damage.</p> <ul style="list-style-type: none"> <li>• Use only compatible water-based solvents to clean plastic structural or pressure-containing parts.</li> <li>• See <b>Technical Data</b> in this and all other equipment instruction manuals. Read fluid and solvent manufacturer's MSDSs and recommendations.</li> </ul>
 	<p><b>TOXIC FLUID OR FUMES HAZARD</b></p> <p>Toxic fluids or fumes can cause serious injury or death if splashed in the eyes or on skin, inhaled, or swallowed.</p> <ul style="list-style-type: none"> <li>• Read MSDSs to know the specific hazards of the fluids you are using.</li> <li>• Route exhaust away from work area. If diaphragm ruptures, fluid may be exhausted into the air.</li> <li>• Store hazardous fluid in approved containers, and dispose of it according to applicable guidelines.</li> </ul>
	<p><b>BURN HAZARD</b></p> <p>Equipment surfaces and fluid that's heated can become very hot during operation. To avoid severe burns:</p> <ul style="list-style-type: none"> <li>• Do not touch hot fluid or equipment.</li> </ul>
	<p><b>PERSONAL PROTECTIVE EQUIPMENT</b></p> <p>Wear appropriate protective equipment when in the work area to help prevent serious injury, including eye injury, hearing loss, inhalation of toxic fumes, and burns. This protective equipment includes but is not limited to:</p> <ul style="list-style-type: none"> <li>• Protective eyewear, and hearing protection.</li> <li>• Respirators, protective clothing, and gloves as recommended by the fluid and solvent manufacturer.</li> </ul>

# Installation

The [Typical Floor Mount Installation, page 12](#), is only a guide for selecting and installing system components. Contact your Graco distributor for assistance in planning a system to suit your needs.

## Tighten Fasteners Before Setup

Before using the pump for the first time, check and retorque all external fasteners. Follow [Torque Instructions, page 16](#). After the first day of operation, retorque the fasteners.

## Mounting

<ul style="list-style-type: none"> <li>• The pump exhaust air may contain contaminants. Ventilate to a remote area. See <a href="#">Air Exhaust Ventilation, page 10</a>.</li> <li>• Never move or lift a pump under pressure. If dropped, the fluid section may rupture. Always follow the <a href="#">Pressure Relief Procedure, page 13</a>, before moving or lifting the pump.</li> </ul>				

1. Be sure the mounting surface can support the weight of the pump, hoses, and accessories, as well as the stress caused during operation.
2. For all mountings, be sure the pump is bolted directly to the mounting surface. Mount the pump horizontally, with the feet at the bottom of the pump. Do not mount the pump on a vertical surface, such as a wall.
3. For ease of operation and service, mount the pump so air valve, air inlet, fluid inlet and fluid outlet ports are easily accessible.

## Grounding

<p>The equipment must be grounded to reduce the risk of static sparking. Static sparking can cause fumes to ignite or explode. Grounding provides an escape wire for the electric current.</p>				

- **Pump:** Loosen the grounding screw (GS). Insert one end of a 12 ga. minimum ground wire (R) behind the grounding screw and tighten the screw securely. Do not exceed 15 in-lb (1.7 N•m). Connect the clamp end of the ground wire to a true earth ground. A ground wire and clamp, Part 238909, is available from Graco.

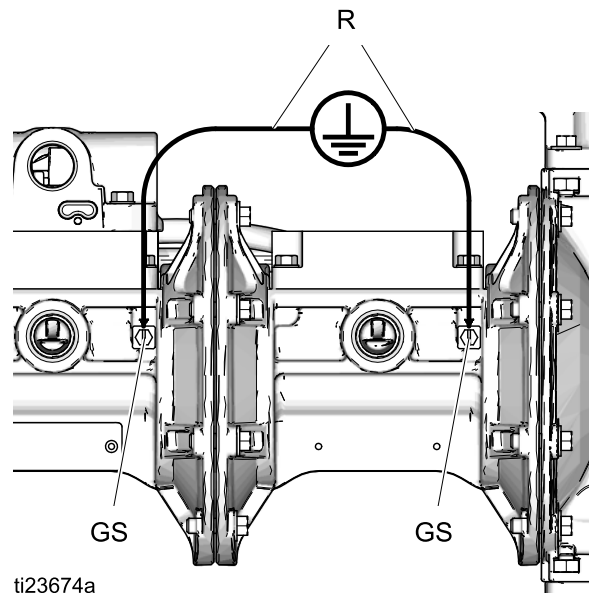

ti23674a  
Figure 1 Grounding Screws and Wires



- **Air and fluid hoses:** Use only grounded hoses with a maximum of 500 ft (150 m) combined hose length to ensure grounding continuity.
- **Air compressor:** Follow manufacturer's recommendations.

Check your system electrical continuity after the initial installation, and then set up a regular schedule for checking continuity to be sure proper grounding is maintained.

## Air Line

See [Typical Floor Mount Installation, page 12](#)

1. Install an air filter/regulator (C). An air line filter removes harmful dirt and moisture from the compressed air supply. Use the regulator and gauge to control the fluid pressure. The fluid stall pressure will be the same as the setting of the air regulator.

2. Locate a bleed-type master air valve (B) close to the pump and use it to relieve trapped air. Be sure the valve is easily accessible from the pump and located downstream from the regulator.

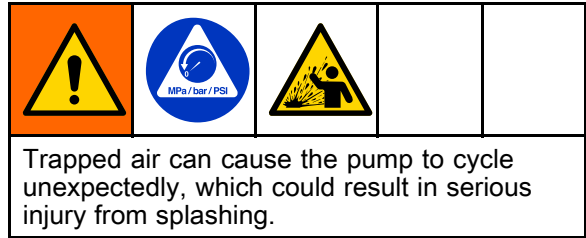

3. Locate another master air valve (E) upstream from all air line accessories and use it to isolate them during cleaning and repair.
4. An adjustable inlet air valve or needle valve (G) may be installed for pump speed control.
5. Install a grounded, flexible air hose (A) between the accessories and the 3/4 npt(f) pump air inlet (D). Use a minimum 5/8 in. (16 mm) ID air hose.

## Air Exhaust Ventilation

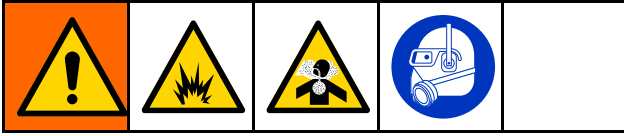

The air exhaust port is 3/4 npt(f). Do not restrict the air exhaust port. Excessive exhaust restriction can cause erratic pump operation.

To provide a remote exhaust:

1. Remove the muffler (T) from the pump air exhaust port.

2. Install a grounded air exhaust hose (U). Connect the muffler (T) to the other end of the hose. The minimum size for the air exhaust hose is 3/4 in. (19 mm) ID. If a hose longer than 15 ft (4.57 m) is required, use a larger diameter hose. Avoid sharp bends or kinks in the hose.
3. Place a container at the end of the air exhaust line to catch fluid in case a diaphragm ruptures. If the diaphragm ruptures, the fluid being pumped will exhaust with the air.

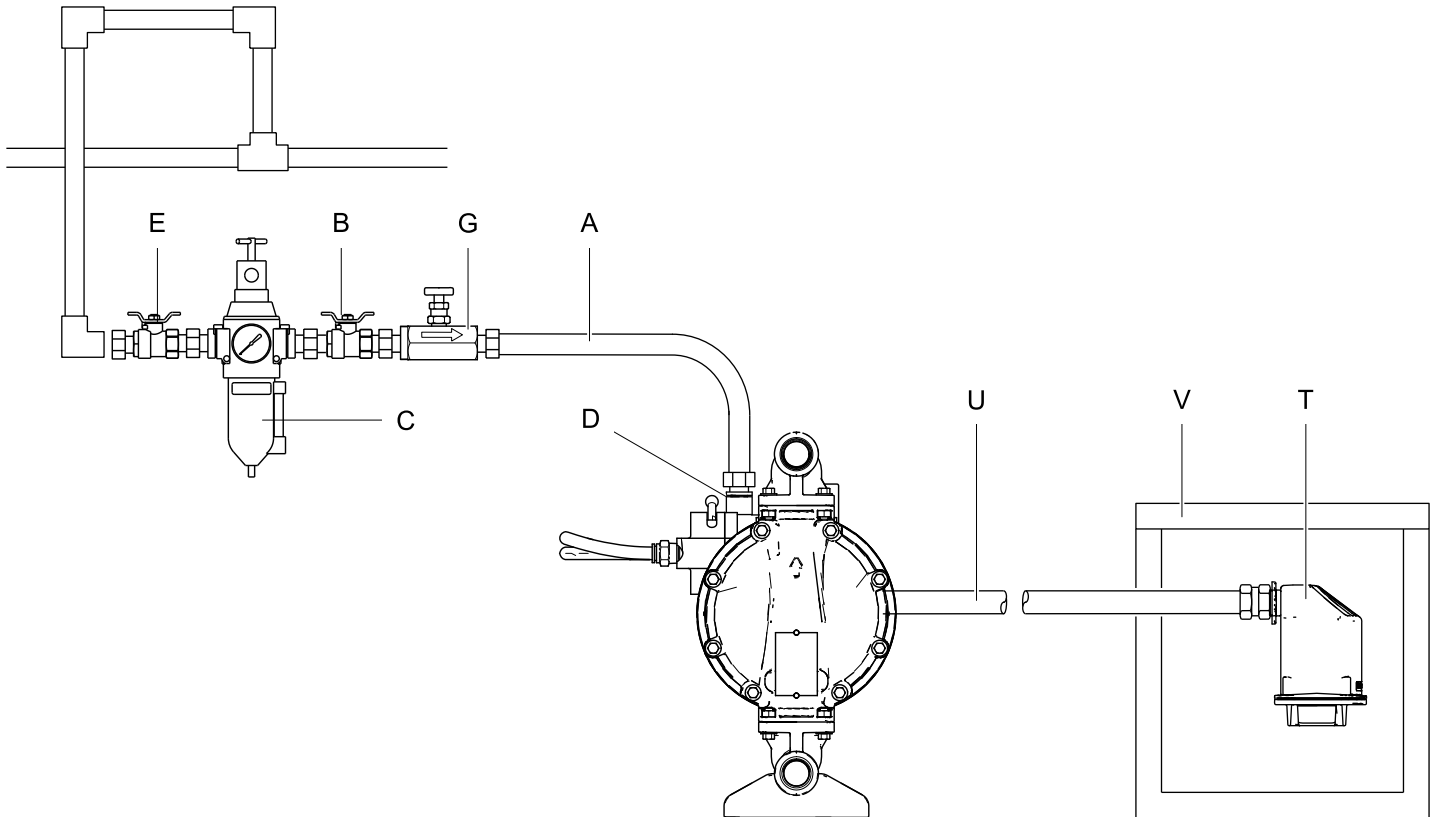

ti23675a

Figure 2 Vent exhaust air

### KEY

- |   |   |
|---|---|
| <b>A</b> Air supply line                    | <b>G</b> Optional needle valve for pump speed adjustment. |
| <b>B</b> Bleed-type master air valve        | <b>T</b> Muffler  |
| <b>C</b> Air filter/regulator               | <b>U</b> Grounded air exhaust hose                        |
| <b>D</b> Air inlet                          | <b>V</b> Container for remote air exhaust                 |
| <b>E</b> Master air valve (for accessories) |   |

## Fluid Supply Line

See [Typical Floor Mount Installation, page 12](#)

1. Use grounded flexible, fluid supply hoses (G). See [Grounding, page 8](#).
2. If the inlet fluid pressure to the pump is more than 25% of the outlet working pressure, the ball check valves will not close fast enough, resulting in inefficient pump operation.
3. Excessive inlet fluid pressure also will shorten diaphragm life. Approximately 3 - 5 psi (0.02-0.03 MPa, 0.21-0.34 bar) should be adequate for most materials.
4. For maximum suction lift (wet and dry), see [Technical Data, page 20](#). For best results, always install the pump as close as possible to the material source.

## Fluid Outlet Line

See [Typical Floor Mount Installation, page 12](#).

1. Use grounded, flexible fluid hoses (L). See [Grounding, page 8](#).
2. Install a fluid drain valve (J) near the fluid outlet.
3. Install a shutoff valve (K) in the fluid outlet line.

## Fluid Inlet and Outlet Ports

**NOTE:** Remove and reverse the manifold(s) to change the orientation of inlet or outlet port(s). Follow [Torque Instructions, page 16](#).

### 1050HP — Aluminum Manifolds

The fluid inlet and outlet manifolds each have two 1 in. npt(f) or bspt threaded ports (M, N). Close off the unused port using the supplied plugs.

### 1050HP — Stainless Steel Manifolds

The fluid inlet and outlet manifolds each have one 1 in. npt(f) or bspt port.

## Typical Floor Mount Installation

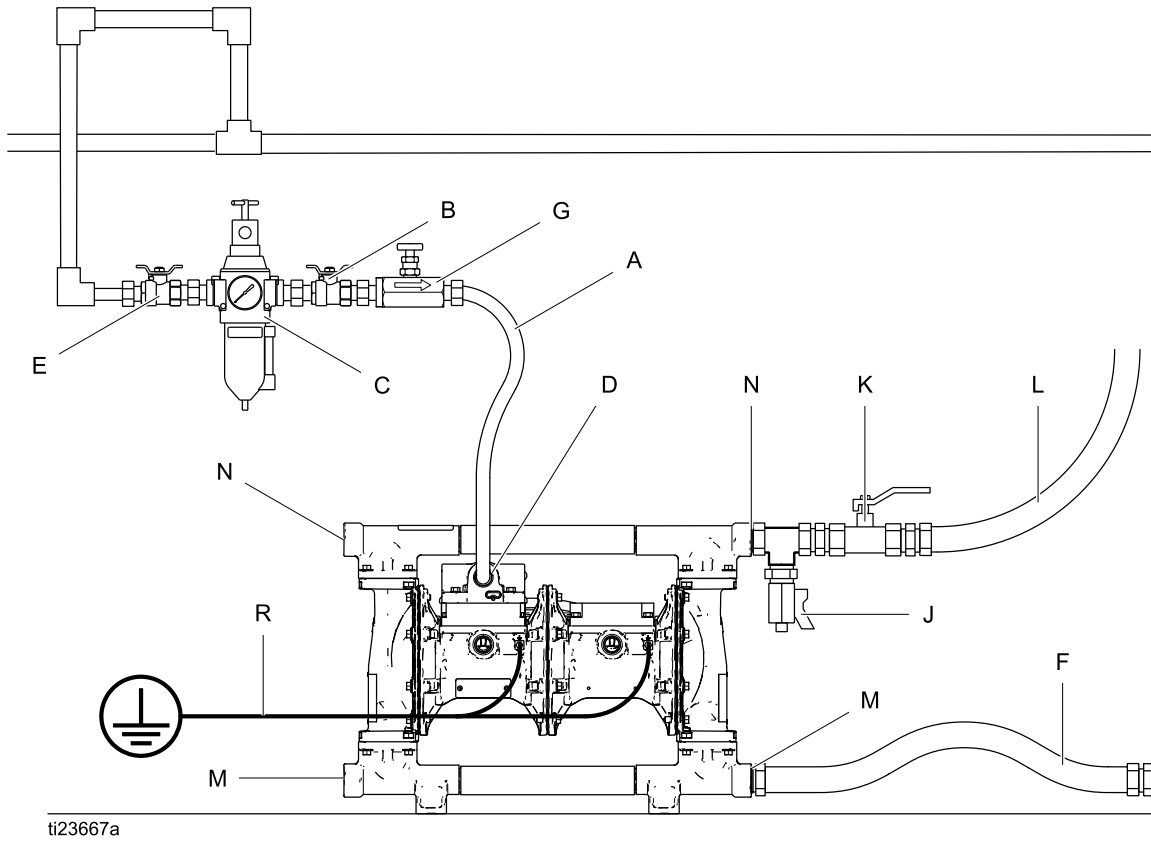

Figure 3 Typical floor mount installation

### KEY

- |   |  |
|---|--|
| <b>A</b> Air supply line                                  | <b>J</b> Fluid drain valve (required)  |
| <b>B</b> Bleed-type master air valve (required for pump)  | <b>K</b> Fluid shutoff valve   |
| <b>C</b> Air filter and regulator                         | <b>L</b> Flexible fluid outlet hose  |
| <b>D</b> Air inlet  | <b>M</b> Fluid inlet (2 ports on aluminum manifolds, 1 port on SST manifolds)  |
| <b>E</b> Master air valve (for accessories)               | <b>N</b> Fluid outlet (2 ports on aluminum manifolds, 1 port on SST manifolds) |
| <b>F</b> Flexible fluid suction hose                      | <b>R</b> Ground wire (required; see <a href="#">Grounding, page 8</a> ).       |
| <b>G</b> Optional needle valve for pump speed adjustment. |  |

# Operation

## Pressure Relief Procedure



Follow the Pressure Relief Procedure whenever you see this symbol.

<p>This equipment stays pressurized until pressure is relieved manually. To help prevent serious injury from pressurized fluid, such as splashing in the eyes or on skin, follow the Pressure Relief Procedure when you stop pumping and before you clean, check, or service the equipment.</p>				

1. Shut off the air supply to the pump.
2. Open the dispensing valve, if used.
3. Shift the high/low pressure lever back and forth two times. Leave the lever in the “Low” position as shown.

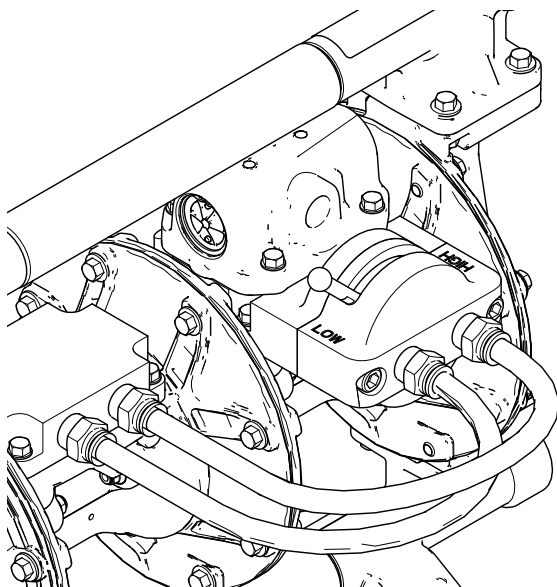

ti23687a

Figure 4 High/Low Pressure Lever

4. Open the fluid drain valve (installed on the system) to relieve all fluid pressure. Have a container ready to catch the drainage.

## Tighten Fasteners Before Setup

Before using the pump for the first time, check and retorque all external fasteners. Follow [Torque Instructions, page 16](#). After the first day of operation, retorque the fasteners.

## Flush the Pump Before First Use

The pump was tested in water. If water could contaminate the fluid you are pumping, flush the pump thoroughly with a compatible solvent. See [Flushing and Storage, page 15](#).

## High/Low Lever

Use the High/Low lever to set the desired pressure mode. When the lever is set to “Low,” the fluid outlet pressure is slightly less than the air inlet pressure. When the lever is set to “High,” the fluid outlet pressure is slightly less than two times the inlet air pressure. Note that the High pressure setting increases both fluid outlet pressure and inlet air consumption.

**NOTE:** The lever must be fully seated into the High or Low position for proper operation.

## Start and Adjust the Pump

1. Be sure the pump is properly grounded. Refer to [Grounding, page 8](#).
2. Ensure the High/Low pressure lever is in the "Low" position before starting the pump.
3. Check all fittings to be sure they are tight. Use a compatible liquid thread sealant on all male threads. Tighten fluid inlet and outlet fittings securely.
4. Place the suction tube (if used) in the fluid to be pumped.

**NOTE:** If fluid inlet pressure to the pump is more than 25% of outlet working pressure, the ball check valves will not close fast enough, resulting in inefficient pump operation.

<b>NOTICE</b>
Excessive fluid inlet pressure can reduce diaphragm life and may result in pump damage.

5. Place the end of the fluid hose into an appropriate container.
6. Close the fluid drain valve.
7. Turn the air regulator knob to 0. Open all bleed-type master air valves.
8. If the fluid hose has a dispensing device, hold it open.

9. Slowly increase air pressure with the air regulator until the pump starts to cycle. Allow the pump to cycle slowly until all air is pushed out of the lines and the pump is primed.

**NOTE:** Use lowest possible air pressure to prime, just enough to cycle the pump. If the pump does not prime as expected, turn air pressure **DOWN**.

10. If you are flushing, run the pump long enough to thoroughly clean the pump and hoses.
11. Close the dispensing valve, if used.
12. Close the bleed-type master air valve.

## Pump Shutdown

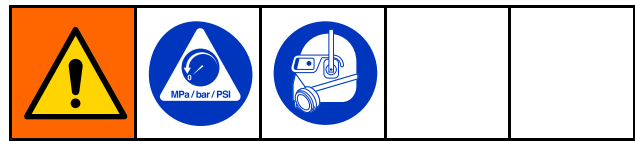

At the end of the work shift and before you check, adjust, clean or repair the system, follow the [Pressure Relief Procedure, page 13](#).

# Maintenance

## Maintenance Schedule

Establish a preventive maintenance schedule, based on the pump's service history. Scheduled maintenance is especially important to prevent spills or leakage due to diaphragm failure.

## Lubrication

The pump is lubricated at the factory. It is designed to require no further lubrication for the life of the pump. An inline lubricator is not needed, and is not recommended, under normal operating conditions.

## Tighten Threaded Connections

Before each use, check all hoses for wear or damage, and replace as necessary. Check to be sure all threaded connections are tight and leak-free. Check fasteners. Tighten or retorque as necessary. Although pump use varies, a general guideline is to retorque fasteners every two months. See [Torque Instructions, page 16](#).

## Flushing and Storage

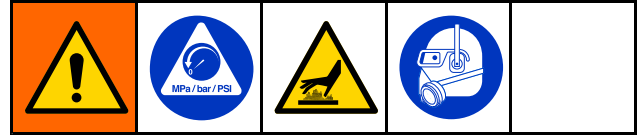

- Flush before fluid can dry in the equipment, at the end of the day, before storing, and before repairing equipment.
- Flush at the lowest pressure possible. Check connectors for leaks and tighten as necessary.
- Flush with a fluid that is compatible with the fluid being dispensed and the equipment wetted parts.

Flush the pump often enough to prevent the fluid you are pumping from drying or freezing in the pump and damaging it. Use a compatible solvent.

Always flush the pump and relieve the pressure before storing it for any length of time.

## Torque Instructions

**NOTE:** All fasteners for the fluid covers, center diaphragm joint, and manifolds have a thread-locking adhesive patch applied to the threads. If this patch is excessively worn, the fasteners may loosen during operation. Replace screws with new ones or apply medium-strength (blue) Loctite or equivalent to the threads.

If fluid cover, center diaphragm joint, or manifold fasteners have been loosened, it is important to torque them using the following procedure to improve sealing.

**NOTE:** Always completely torque the fluid covers and center diaphragm joint before torquing the manifolds.

Start all fluid cover or center diaphragm joint screws a few turns. Then turn down each screw just until head contacts cover. Then turn each screw by 1/2 turn or less working in a crisscross pattern to specified torque. Repeat for manifolds.

**Fluid cover, center diaphragm joint, and manifold fasteners:** 100 in-lb (11.3 N•m)

Lubricate air valve fasteners prior to reassembly to prevent galling. Retorque the air valve fasteners in a crisscross pattern to specified torque.

**Air valve fasteners:** 80 in-lb (9.0 N•m)

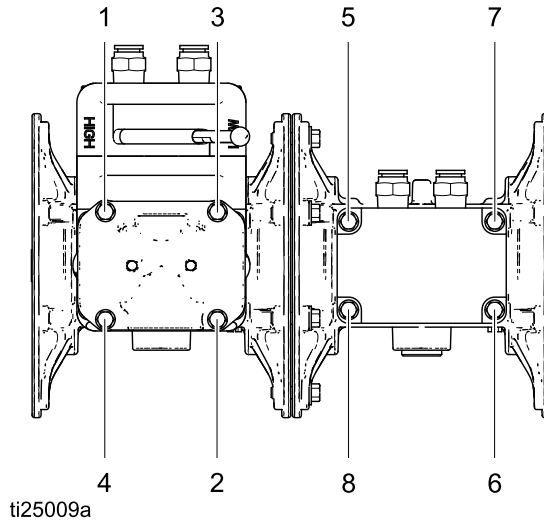

**Air Valve Fasteners**

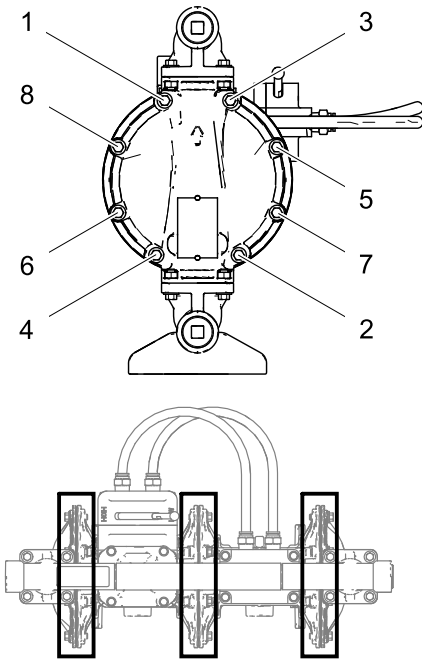

**Fluid Covers and Center Diaphragm Joint**

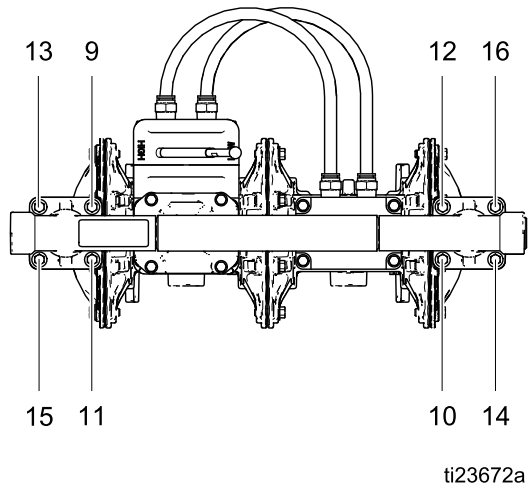

**Manifolds**



# Dimensions and Mounting

**KEY**

	<b>Aluminum</b>	<b>SST</b>	<b>Aluminum and SST</b>
<b>A</b>	12.7 in (323 mm)	11.8 in (300 mm)	<b>H</b> 6.2 in (157 mm)
<b>B</b>	14.4 in (366 mm)	12.9 in (328 mm)	<b>J</b> 9.4 in (239 mm)
<b>C</b>	15.3 in (389 mm)	13.7 in (348 mm)	<b>K</b> 15.6 in (396 mm)
<b>D</b>	10.9 in (277 mm)	9.5 in (241 mm)	<b>L</b> 3/4 npt(f) Air Inlet
<b>E</b>	1.8 in (46 mm)	1.1 in (28 mm)	<b>M</b> 1 in npt(f) or 1 in. bspt Fluid Inlet (2 for aluminum manifolds; 1 for SST manifolds)
<b>F</b>	10.8 in (274 mm)	10.7 in (272 mm)	<b>N</b> 1 in npt(f) or 1 in. bspt Fluid Outlet (2 for aluminum manifolds; 1 for SST manifolds)
<b>G</b>	21.5 in (546 mm)	20.6 in (523 mm)	<b>P</b> 3/4 npt(f) Air Exhaust Port

**NOTE:** All dimensions are approximate.

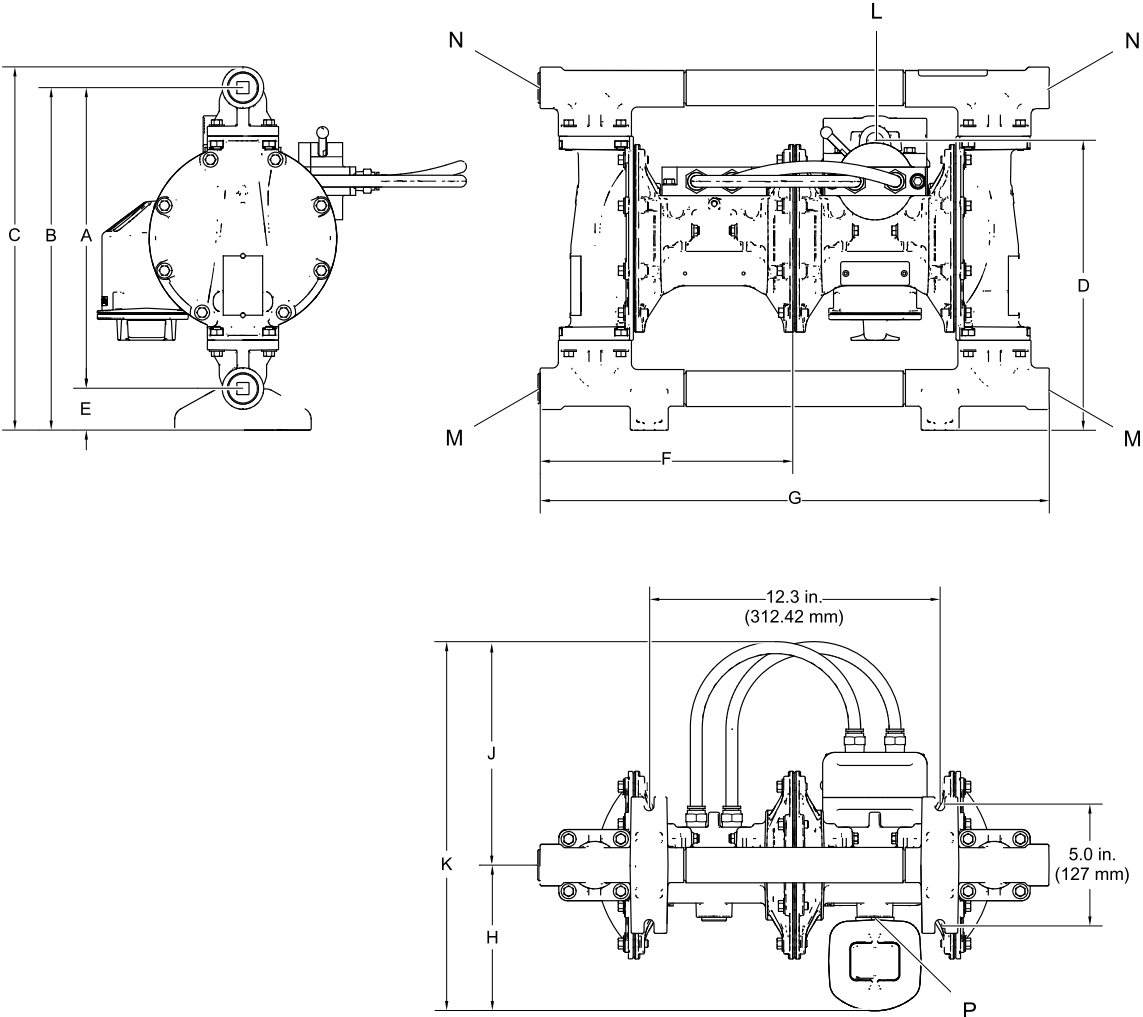

ti23673a

# Performance Charts

## Low Pressure Setting

### Operating Air Pressure

- A**  
125 psi (0.86 MPa, 8.6 bar)
- B**  
100 psi (0.7 MPa, 7.0 bar)
- C**  
70 psi (0.48 MPa, 4.8 bar)
- D**  
40 psi (0.28 MPa, 2.8 bar)
- E**  
20 psi (0.14 MPa, 1.4 bar)

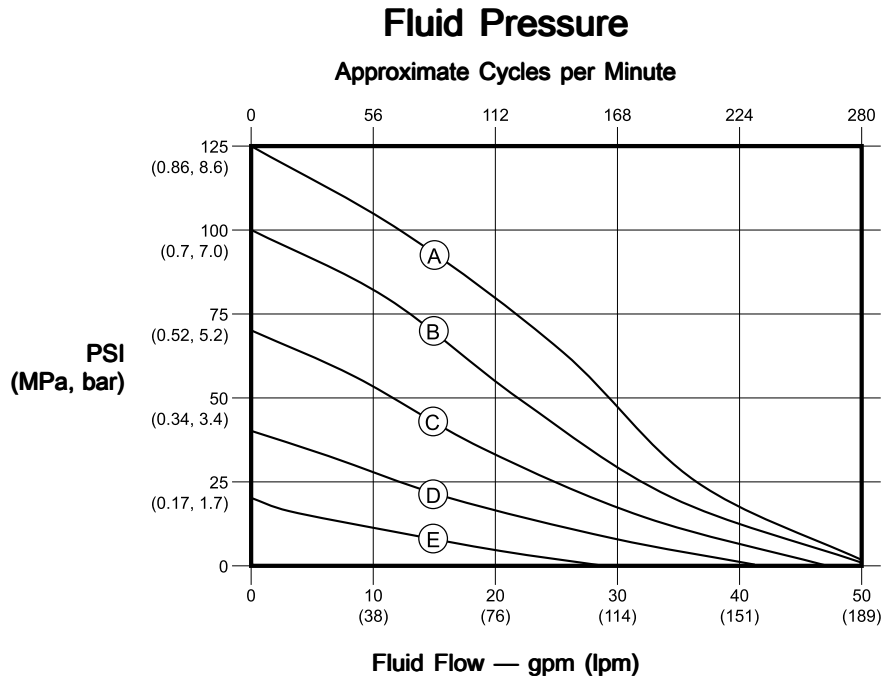

### How to Read the Charts

1. Locate fluid flow rate along bottom of chart.
2. Follow vertical line up to intersection with selected operating air pressure curve.
3. Follow left to scale to read **fluid outlet pressure** (top chart) or **air consumption** (bottom chart)

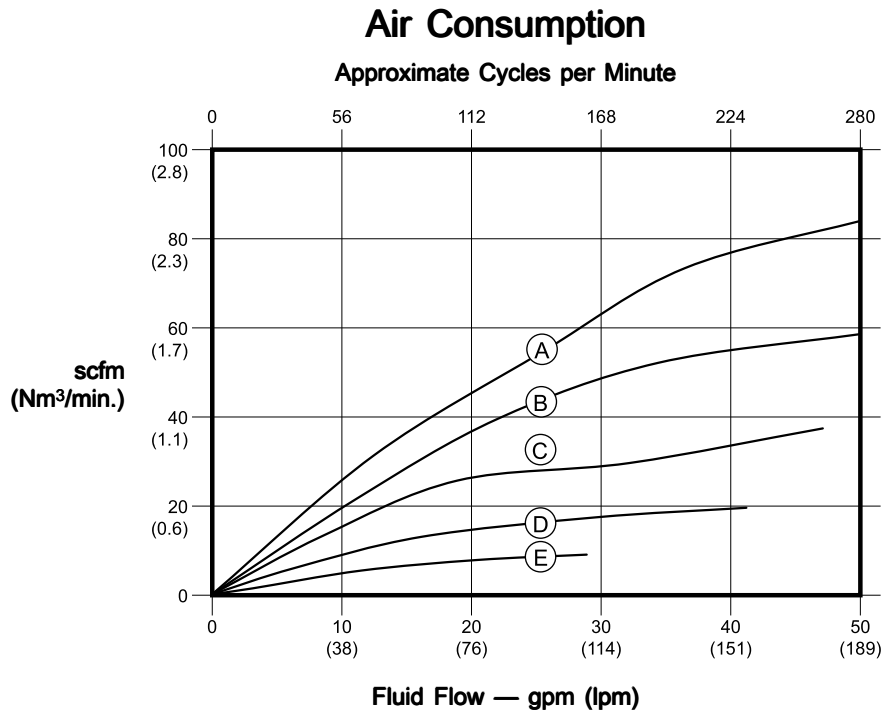

## High Pressure Setting

### Operating Air Pressure

- A**  
125 psi (0.86 MPa, 8.6 bar)
- B**  
100 psi (0.7 MPa, 7.0 bar)
- C**  
70 psi (0.48 MPa, 4.8 bar)
- D**  
40 psi (0.28 MPa, 2.8 bar)
- E**  
20 psi (0.14 MPa, 1.4 bar)

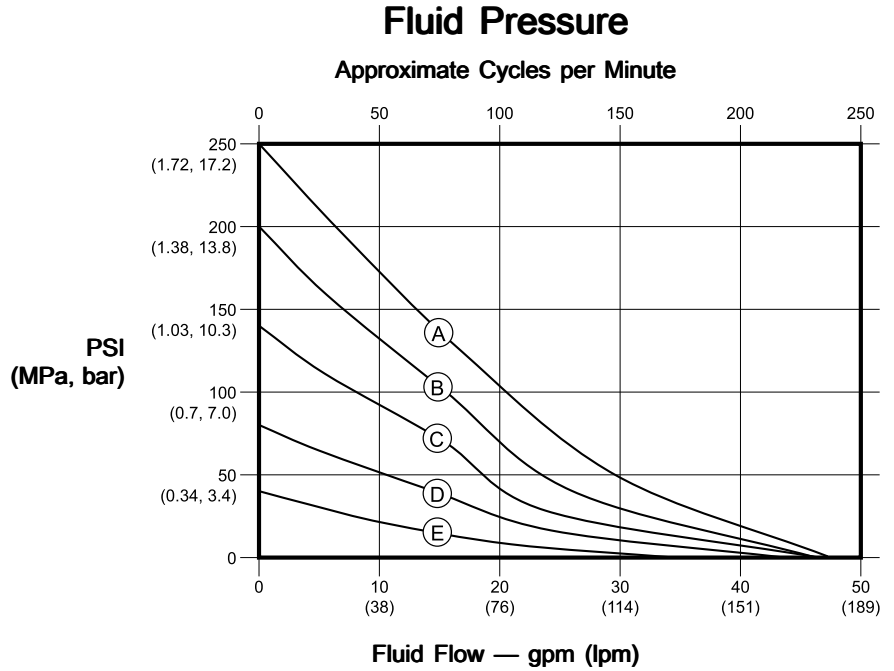

### How to Read the Charts

1. Locate fluid flow rate along bottom of chart.
2. Follow vertical line up to intersection with selected operating air pressure curve.
3. Follow left to scale to read **fluid outlet pressure** (top chart) or **air consumption** (bottom chart)

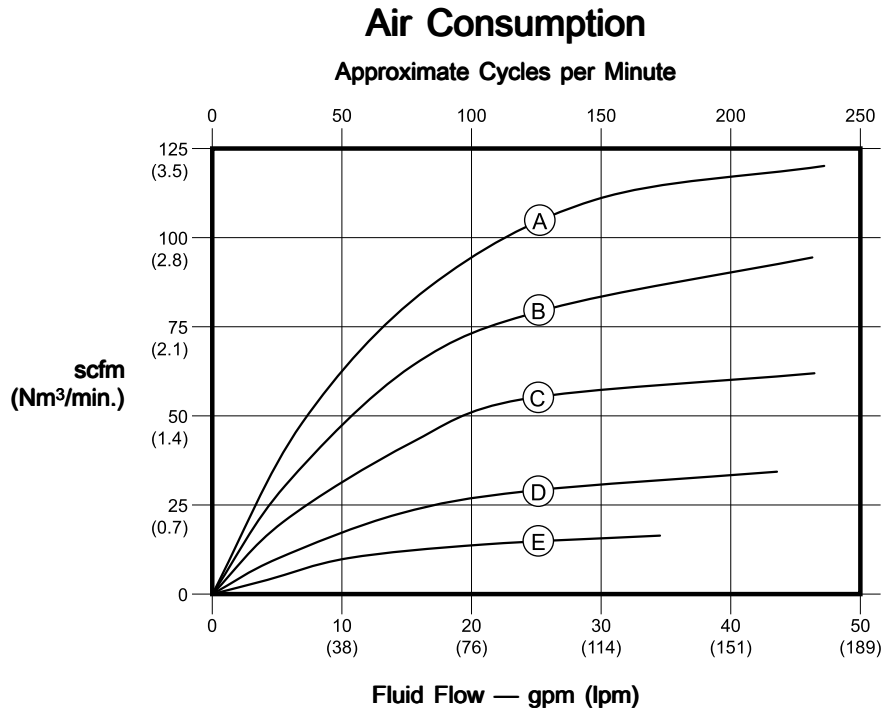

# Technical Data

	US	Metric
<b>Maximum fluid working pressure</b>	250 psi	1.72 MPa, 17.2 bar
<b>Air pressure operating range</b>	20-125 psi	0.14-0.86 MPa, 1.4-8.6 bar
<b>Fluid displacement per cycle</b>		
Low Pressure Setting	0.17 g	0.64 l
High Pressure Setting	0.20 g	0.76 l
<b>Air consumption</b>	<b>at 70 psi, 20 gpm</b>	<b>at 4.8 bar, 76 lpm</b>
Low Pressure Setting	26 scfm	0.7 cubic meters per minute
High Pressure Setting	51 scfm	1.4 cubic meters per minute
<b>Maximum values with water as media under submerged inlet conditions at ambient temperature:</b>		
Maximum air consumption		
Low Pressure Setting	59 scfm	1.7 cubic meters per minute
High Pressure Setting	95 scfm	2.7 cubic meters per minute
Maximum free-flow delivery		
Low Pressure Setting	50 gpm	189 lpm
High Pressure Setting	46 gpm	174 lpm
Maximum pump speed		
Low Pressure Setting	280 cpm	
High Pressure Setting	225 cpm	
Maximum suction lift (varies widely based on ball/seat selection and wear, operating speed, material properties, and other variables)	16 ft dry, 29 ft wet	4.9 m dry 8.8 m wet
<b>Maximum size pumpable solids</b>	1/8 in	3.2 mm
<b>Recommended cycle rate for continuous use</b>	93-140 cpm (in Low or High setting)	
<b>Recommended cycle rate for circulation systems</b>	20 cpm (in Low or High setting)	
<b>Air inlet size</b>	3/4 npt(f)	
<b>Fluid inlet size</b>	1 in. npt(f) or 1 in. bspt	
<b>Fluid outlet size</b>	1 in. npt(f) or 1 in. bspt	
<b>Weight</b>	48 lb (aluminum manifolds) 60 lb (SST manifolds)	21.8 kg (aluminum manifolds) 27.2 kg (SST manifolds)

<b>Sound Power</b> (measured per ISO-9614-2)	
At 70 psi (0.48 MPa, 4.8 bar) and 50 cpm	
Low Pressure Setting	78 dBa
High Pressure Setting	91 dBa
At 100 psi (0.7 MPa, 7.0 bar) and full flow	
Low Pressure Setting	90 dBa
High Pressure Setting	102 dBa
<b>Sound Pressure</b> (tested 3.28 ft [1 m] from equipment)	
At 70 psi (0.48 MPa, 4.8 bar) and 50 cpm	
Low Pressure Setting	84 dBa
High Pressure Setting	96 dBa
At 100 psi (0.7 MPa, 7.0 bar) and full flow	
Low Pressure Setting	84 dBa
High Pressure Setting	96 dBa
<b>Wetted parts</b>	aluminum plus the material(s) chosen for seat, ball, and diaphragm options.
<b>Non-wetted external parts</b>	aluminum, coated carbon steel

## Fluid Temperature Range

### NOTICE

Temperature limits are based on mechanical stress only. Certain chemicals will further limit the fluid operating temperature range. Stay within the temperature range of the most-restricted wetted component. Operating at a fluid temperature that is too high or too low for the components of your pump may cause equipment damage.

Diaphragm/Ball Material	Fluid Temperature Range	
	Fahrenheit	Celsius
Buna-N (BN)	10° to 180°F	-12° to 82°C
Geolast (GE)	-40° to 150°F	-40° to 66°C
Polychloroprene overmolded diaphragm (CO) or Polychloroprene check balls (CW)	0° to 180°F	-18° to 82°C
2-Piece PTFE/Santoprene Diaphragm	40° to 180°F	4° to 82°C
Santoprene® (SP)	-40° to 180°F	-40° to 82°C

## California Proposition 65

### CALIFORNIA RESIDENTS

 **WARNING:** Cancer and reproductive harm — [www.P65warnings.ca.gov](http://www.P65warnings.ca.gov).

# Graco Standard Husky Pump Warranty

Graco warrants all equipment referenced in this document which is manufactured by Graco and bearing its name to be free from defects in material and workmanship on the date of sale to the original purchaser for use. With the exception of any special, extended, or limited warranty published by Graco, Graco will, for a period of five years from the date of sale, repair or replace any part of the equipment determined by Graco to be defective. This warranty applies only when the equipment is installed, operated and maintained in accordance with Graco's written recommendations.

This warranty does not cover, and Graco shall not be liable for general wear and tear, or any malfunction, damage or wear caused by faulty installation, misapplication, abrasion, corrosion, inadequate or improper maintenance, negligence, accident, tampering, or substitution of non-Graco component parts. Nor shall Graco be liable for malfunction, damage or wear caused by the incompatibility of Graco equipment with structures, accessories, equipment or materials not supplied by Graco, or the improper design, manufacture, installation, operation or maintenance of structures, accessories, equipment or materials not supplied by Graco.

This warranty is conditioned upon the prepaid return of the equipment claimed to be defective to an authorized Graco distributor for verification of the claimed defect. If the claimed defect is verified, Graco will repair or replace free of charge any defective parts. The equipment will be returned to the original purchaser transportation prepaid. If inspection of the equipment does not disclose any defect in material or workmanship, repairs will be made at a reasonable charge, which charges may include the costs of parts, labor, and transportation.

**THIS WARRANTY IS EXCLUSIVE, AND IS IN LIEU OF ANY OTHER WARRANTIES, EXPRESS OR IMPLIED, INCLUDING BUT NOT LIMITED TO WARRANTY OF MERCHANTABILITY OR WARRANTY OF FITNESS FOR A PARTICULAR PURPOSE.**

Graco's sole obligation and buyer's sole remedy for any breach of warranty shall be as set forth above. The buyer agrees that no other remedy (including, but not limited to, incidental or consequential damages for lost profits, lost sales, injury to person or property, or any other incidental or consequential loss) shall be available. Any action for breach of warranty must be brought within six (6) years of the date of sale..

**GRACO MAKES NO WARRANTY, AND DISCLAIMS ALL IMPLIED WARRANTIES OF MERCHANTABILITY AND FITNESS FOR A PARTICULAR PURPOSE, IN CONNECTION WITH ACCESSORIES, EQUIPMENT, MATERIALS OR COMPONENTS SOLD BUT NOT MANUFACTURED BY GRACO.** These items sold, but not manufactured by Graco (such as electric motors, switches, hose, etc.), are subject to the warranty, if any, of their manufacturer. Graco will provide purchaser with reasonable assistance in making any claim for breach of these warranties..

In no event will Graco be liable for indirect, incidental, special or consequential damages resulting from Graco supplying equipment hereunder, or the furnishing, performance, or use of any products or other goods sold hereto, whether due to a breach of contract, breach of warranty, the negligence of Graco, or otherwise.

## FOR GRACO CANADA CUSTOMERS

The Parties acknowledge that they have required that the present document, as well as all documents, notices and legal proceedings entered into, given or instituted pursuant hereto or relating directly or indirectly hereto, be drawn up in English. Les parties reconnaissent avoir convenu que la rédaction du présente document sera en Anglais, ainsi que tous documents, avis et procédures judiciaires exécutés, donnés ou intentés, à la suite de ou en rapport, directement ou indirectement, avec les procédures concernées.

## Graco Information

For the latest information about Graco products, visit [www.graco.com](http://www.graco.com).  
For patent information, see [www.graco.com/patents](http://www.graco.com/patents).

**To place an order**, contact your Graco Distributor or call to identify the nearest distributor.  
**Phone:** 612-623-6921 **or Toll Free:** 1-800-328-0211 **Fax:** 612-378-3505

All written and visual data contained in this document reflects the latest product information available at the time of publication.

Graco reserves the right to make changes at any time without notice.  
Original Instructions. This manual contains English. MM 334014

**Graco Headquarters:** Minneapolis  
**International Offices:** Belgium, China, Japan, Korea

**GRACO INC. AND SUBSIDIARIES • P.O. BOX 1441 • MINNEAPOLIS MN 55440-1441 • USA**  
**Copyright 2014, Graco Inc. All Graco manufacturing locations are registered to ISO 9001.**

[www.graco.com](http://www.graco.com)  
Revision D, March 2020