

XMTM PFP

Plural-Component Sprayer

3A2989Z

EN

For spraying two-component passive fire protection (PFP) intumescent epoxies. For professional use only.



Important Safety Instructions

Read all warnings and instructions in this manual and in all supplied manuals before using the equipment. Save all instructions.

See page 3 for model information, including maximum working pressure and approvals.

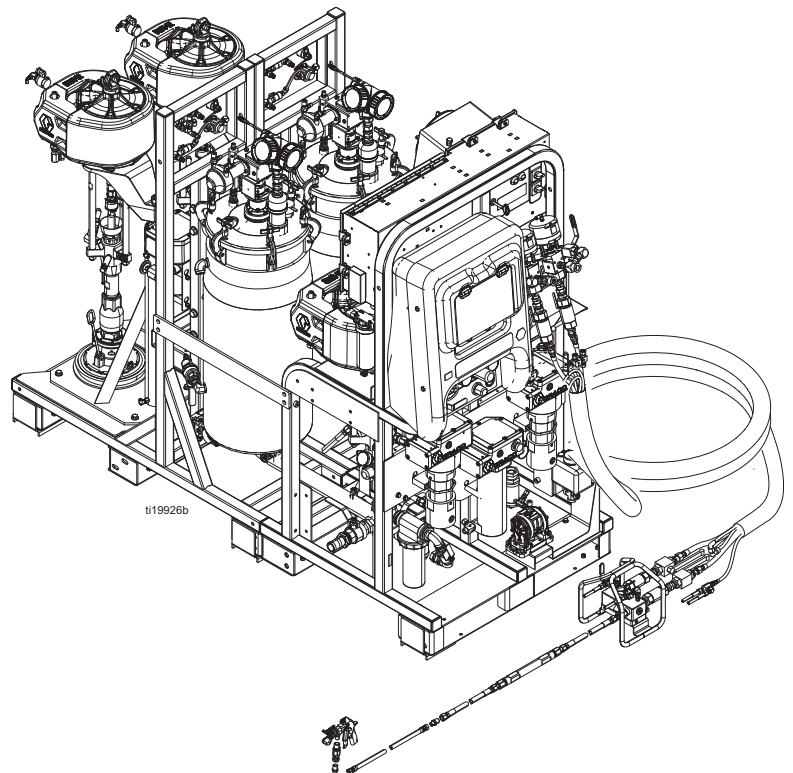

Contents

Related Manuals 2

Models 3

Warnings 4

 Keep Components A and B Separate 7

 Components A and B 7

 Changing Materials 7

Component Identification 8

Grounding 8

Pressure Relief Procedure 9

Flush Mixed Material 11

Troubleshooting 13

Repair 13

 Replace Air Filter Element 13

 User Interface/Control Box 15

 Junction Box 19

 Purge Box 20

 Air Controls 23

 Dosing Valve Assembly 25

 Sensors 26

 Pump Assembly (System Module) 27

 Pail Feed RAM Pump Assembly
 (Feed Module) 28

 Flush Pump 28

 Heaters 29

 Replace Radar Level Sensor 30

 Set Up a New Radar Level Sensor 31

Electrical Schematics 33

 Non-Hazardous Location Schematic 33

 Hazardous Location Schematics 40

Parts 49

 XM PFP System Subassemblies 50

 Base System (262878, 262941)
 Subassemblies 63

 Feed Module Sub-Assemblies 77

 Accessories 83

Dimensions 84

Technical Specifications 85

California Proposition 65 87

Graco Standard Warranty 88



Graco Information 88

Related Manuals

Manuals are available at www.graco.com.

Manual in English	Description
3A2776	XM PFP Setup - Operation
3A2988	XM PFP Mix Manifold - Instructions - Parts
3A2799	XHF™ Spray Gun - Instructions
Heaters	
309524	Viscon® HP High Pressure Fluid Heater Instructions - Parts
3A2954	Viscon HF High Flow, High Pressure Fluid Heater - Instructions - Parts
Pumps, Motors, Supply Systems	
308652	Husky™ 205 Air-Operated Diaphragm Pumps - Instructions - Parts
311762	Xtreme® Lowers - Instructions - Parts
312375	Check-Mate® Displacement Pumps Instructions - Parts
312376	Check-Mate Pump Packages - Instructions - Parts
312792	Merkur® Pump Repair - Parts
312794	Merkur Pump Assembly Instructions - Parts
312796	NXT Air Motor Instructions - Parts
313526	Supply Systems - Operation
313527	Supply Systems Repair - Parts
312374	Air Control Instructions - Parts
Accessories	
332073	Hot Water Flush Kit - Instructions
3A2987	Air Dryer Kit - Instructions
406691	Hose Rack - Parts
334931	Caster Kit - Instructions
Other	
313342	Dosing Valve Instructions - Parts
306861	Ball Valves Instructions - Parts
307005	High Pressure Swivel Instructions - Parts
308169	Air Filters, Lubricators, and Kits - Instructions - Parts
407061	Simulation XM PFP Display Module - Instructions
3A1244	Graco Control Architecture Module Programming - Instructions
334939	1:1 Ratio Adapter Kit - Instructions
3A3072	Heater Upgrade Kit - Instructions
3A5423	XL6500 and XL3400 Air Motors - Parts



Models









System	Series	Location	Ratio Range	Approvals
24W626	B	Non-Hazardous	1:1 to 1.5:1	<p>Not for use in explosive atmospheres or hazardous locations.</p>  <p>Intertek 9902471 Certified to CAN/CSA C22.2 No. 88 Conforms to UL 499</p>
262869	B		1.5:1 to 4:1	
262945	A	Hazardous	1:1 to 1.5:1	 <p>Intertek 9902471 Certified to CAN/CSA C22.2 No. 88 Conforms to UL 499</p> <p>ATEX Ratings:  II 2 G Ex db ia pxb IIA T3 Gb ATEX Certificate No. ITS15ATEX18241X</p> <p>IECEX Ratings Ex db ia pxb IIA T3 Gb IECEX Certificate No. IECEX ETL 15.0020X Ta = 0°C to 54°C</p> <p>See Technical Specifications, page 85, for additional information.</p>
262943	A		1.5:1 to 4:1	

Maximum Fluid Working Pressure	Maximum Air Working Pressure
<p><i>A and B Materials:</i> 6000 psi (41 MPa, 414 bar)</p> <p><i>Flushing Fluid:</i> 4500 psi (31 MPa, 310 bar)</p> <p><i>Heating Fluid:</i> 100 psi (0.7 MPa, 7 bar)</p>	<p><i>Supply</i> 150 psi (1.0 MPa, 10.3 bar)</p> <p><i>Maximum Setpoint</i> Main Pump: 100 psi (0.7 MPa, 7 bar) Feed Pump: 65 psi (0.45 MPa, 4.5 bar)</p>

Warnings

The following warnings are for the setup, use, grounding, maintenance, and repair of this equipment. The exclamation point symbol alerts you to a general warning and the hazard symbols refer to procedure-specific risks. When these symbols appear in the body of this manual or on warning labels, refer back to these Warnings. Product-specific hazard symbols and warnings not covered in this section may appear throughout the body of this manual where applicable.

 DANGER	
	<p>SEVERE ELECTRIC SHOCK HAZARD</p> <p>This equipment can be powered by more than 240 V. Contact with this voltage will cause death or serious injury.</p> <ul style="list-style-type: none"> • Turn off and disconnect power at main switch before disconnecting any cables and before servicing equipment. • This equipment must be grounded. Connect only to grounded power source. • All electrical wiring must be done by a qualified electrician and comply with all local codes and regulations.

 WARNING	
  	<p>SPECIAL CONDITIONS FOR SAFE USE</p> <ul style="list-style-type: none"> • Potential risk of electrostatic discharge. See instructions for guidance to minimize the risk of electrostatic discharge. • The system must be earthed using copper conductors according to the installation instructions. All intrinsically safe circuits must be connected to ground at one point. • For information on the required dimensions of the flameproof joints contact the holder of this certificate (Graco Inc.); Flame-path joints are not intended to be repaired. • Special fasteners for securing equipments covers on the flameproof heaters shall have a minimum yield strength of 1,100 MPa and be corrosion resistant and sized M8 x 1.25 x 30.
   	<p>FIRE AND EXPLOSION HAZARD</p> <p>Flammable fumes, such as solvent and paint fumes, in work area can ignite or explode. Paint or solvent flowing through the equipment can cause static sparking. To help prevent fire and explosion:</p> <ul style="list-style-type: none"> • Use equipment only in well ventilated area. • Eliminate all ignition sources; such as pilot lights, cigarettes, portable electric lamps, and plastic drop cloths (potential static sparking). • Ground all equipment in the work area. See Grounding instructions. • Never spray or flush solvent at high pressure. • Keep work area free of debris, including solvent, rags and gasoline. • Do not plug or unplug power cords, or turn power or light switches on or off when flammable fumes are present. • Use only grounded hoses. • Hold gun firmly to side of grounded pail when triggering into pail. Do not use pail liners unless they are anti-static or conductive. • Stop operation immediately if static sparking occurs or you feel a shock. Do not use equipment until you identify and correct the problem. • Keep a working fire extinguisher in the work area.



WARNING

**SKIN INJECTION HAZARD**

High-pressure fluid from gun, hose leaks, or ruptured components will pierce skin. This may look like just a cut, but it is a serious injury that can result in amputation. **Get immediate surgical treatment.**

- Do not spray without tip guard and trigger guard installed.
- Engage trigger lock when not spraying.
- Do not point gun at anyone or at any part of the body.
- Do not put your hand over the spray tip.
- Do not stop or deflect leaks with your hand, body, glove, or rag.
- Follow the **Pressure Relief Procedure** when you stop spraying and before cleaning, checking, or servicing equipment.
- Tighten all fluid connections before operating the equipment.
- Check hoses and couplings daily. Replace worn or damaged parts immediately.

**BURN HAZARD**

Equipment surfaces and fluid that's heated can become very hot during operation. To avoid severe burns:

- Do not touch hot fluid or equipment.

**MOVING PARTS HAZARD**





Moving parts can pinch, cut or amputate fingers and other body parts.

- Keep clear of moving parts.
- Do not operate equipment with protective guards or covers removed.
- Pressurized equipment can start without warning. Before checking, moving, or servicing equipment, follow the **Pressure Relief Procedure** and disconnect all power sources.





WARNING

 	<p>EQUIPMENT MISUSE HAZARD</p> <p>Misuse can cause death or serious injury.</p> <ul style="list-style-type: none"> • Do not operate the unit when fatigued or under the influence of drugs or alcohol. • Do not exceed the maximum working pressure or temperature rating of the lowest rated system component. See Technical Specifications in all equipment manuals. • Use fluids and solvents that are compatible with equipment wetted parts. See Technical Data in all equipment manuals. Read fluid and solvent manufacturer's warnings. For complete information about your material, request Safety Data Sheet (SDS) from distributor or retailer. • Do not leave the work area while equipment is energized or under pressure. • Turn off all equipment and follow the Pressure Relief Procedure when equipment is not in use. • Check equipment daily. Repair or replace worn or damaged parts immediately with genuine manufacturer's replacement parts only. • Do not alter or modify equipment. Alterations or modifications may void agency approvals and create safety hazards. • Make sure all equipment is rated and approved for the environment in which you are using it. • Use equipment only for its intended purpose. Call your distributor for information. • Route hoses and cables away from traffic areas, sharp edges, moving parts, and hot surfaces. • Do not kink or over bend hoses or use hoses to pull equipment. • Keep children and animals away from work area. • Comply with all applicable safety regulations.
	<p>TOXIC FLUID OR FUMES HAZARD</p> <p>Toxic fluids or fumes can cause serious injury or death if splashed in the eyes or on skin, inhaled, or swallowed.</p> <ul style="list-style-type: none"> • Read Safety Data Sheets (SDSs) to know the specific hazards of the fluids you are using. • Store hazardous fluid in approved containers, and dispose of it according to applicable guidelines.
	<p>SPLATTER HAZARD</p> <p>Hot or toxic fluid can cause serious injury if splashed in the eyes or on skin. During blow off of platen, splatter may occur.</p> <ul style="list-style-type: none"> • Use minimum air pressure when removing platen from drum.
	<p>PERSONAL PROTECTIVE EQUIPMENT</p> <p>Wear appropriate protective equipment when in the work area to help prevent serious injury, including eye injury, hearing loss, inhalation of toxic fumes, and burns. Protective equipment includes but is not limited to:</p> <ul style="list-style-type: none"> • Protective eyewear, and hearing protection. • Respirators, protective clothing, and gloves as recommended by the fluid and solvent manufacturer.

Keep Components A and B Separate



Cross-contamination can result in cured material in fluid lines which could cause serious injury or damage equipment. To prevent cross-contamination:

- **Never** interchange component A and component B wetted parts.
- Never use solvent on one side if it has been contaminated from the other side.

Components A and B

IMPORTANT!

Material suppliers can vary in how they refer to plural component materials.

Be aware that in this manual:

Component A refers to resin or major volume.

Component B refers to the hardener or minor volume.

This equipment doses the B component into the A component flow. An integration hose must always be used after the mix manifold and before the static mixer.

Changing Materials

NOTICE

Changing the material types used in your equipment requires special attention to avoid equipment damage and downtime.

- When changing materials, flush the equipment multiple times to ensure it is thoroughly clean.
- Always clean the fluid inlet strainers after flushing.
- Check with your material manufacturer for chemical compatibility.
- When changing between epoxies and urethanes or polyureas, disassemble and clean all fluid components and change hoses. Epoxies often have amines on the B (hardener) side. Polyureas often have amines on the B (resin) side.

Component Identification

See sprayer Setup - Operation manual for component identification.

Grounding



The equipment must be grounded to reduce the risk of static sparking and electric shock. All internal earth grounding must use only copper wires. See **Electrical Schematics**, page 33, for wire size. Electric or static sparking can cause fumes to ignite or explode. Improper grounding can cause electric shock. Grounding provides an escape wire for the electric current.

All components shipped from the factory are electrically bonded through ground wires. Ground the electrical connection properly according to local codes.

Pressure Relief Procedure



Follow the Pressure Relief Procedure whenever you see this symbol.

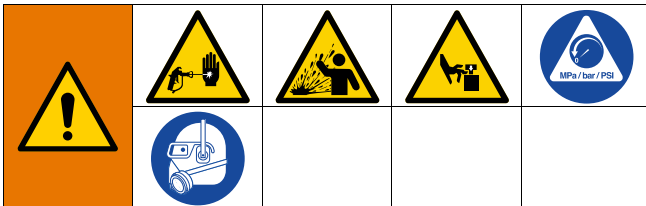

This equipment stays pressurized until pressure is manually relieved. To help prevent serious injury from pressurized fluid, such as skin injection, splashing fluid and moving parts, follow the Pressure Relief Procedure when you stop spraying and before cleaning, checking, or servicing the equipment.

1. Engage trigger lock.

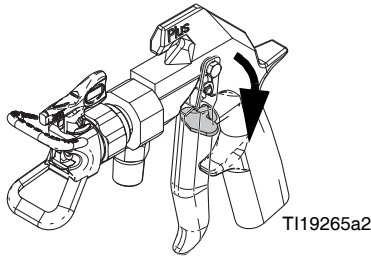

2. If the system will be shut down for more than a few hours, perform **Park Fluid Pump Rods** procedure in XM PFP Operation manual to prevent fluid hardening on the pump shaft.

3. Press  (Stop button).

4. Slide the feed pump air supply valve (DF) and director valve air supply valve (DA) to the OFF position.

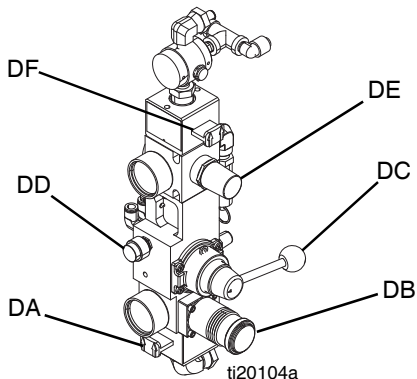

FIG. 1: Feed Pump Controls

NOTICE

The material may expand when air pressure is removed. This can cause the tank to overflow and damage the parts attached to the tank lid. To prevent overflowing the tank, never relieve air pressure in the tank unless the tank is less than half full. Verify tank material level on the user interface **Supply Screen**.

5. **If necessary to relieve tank air pressure:** close both feed system air control ball valves (CT, CS) and back out the air pressure regulator (CP). Open the valves on the tank lids for full tank de-pressurization. Pressure gauge (CR) should read 0 psi.

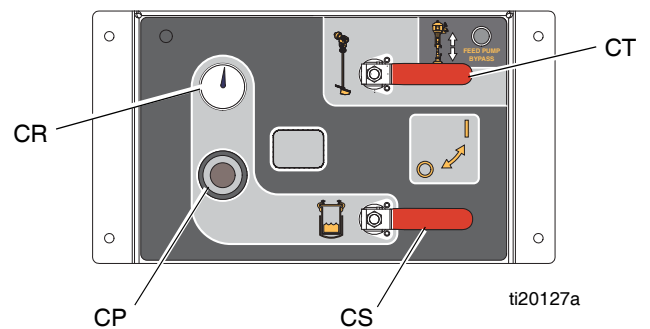
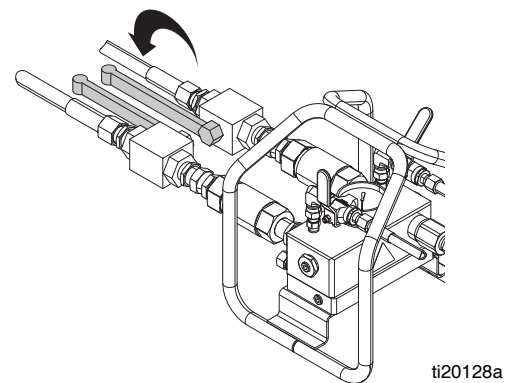

FIG. 2

6. Open mix manifold ball valves.



Pressure Relief Procedure

7. Open recirculation ball valves.

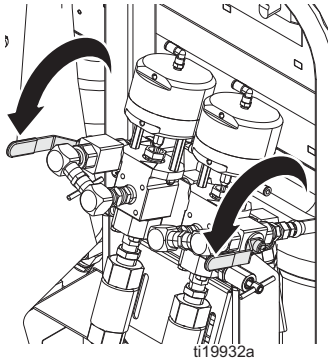

10. Engage trigger lock.

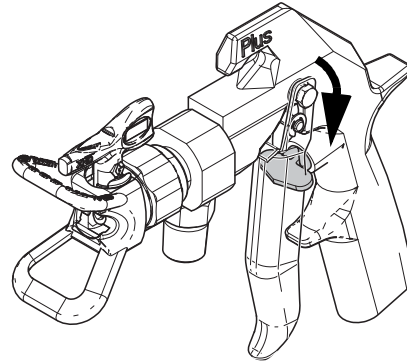

8. Disengage trigger lock.

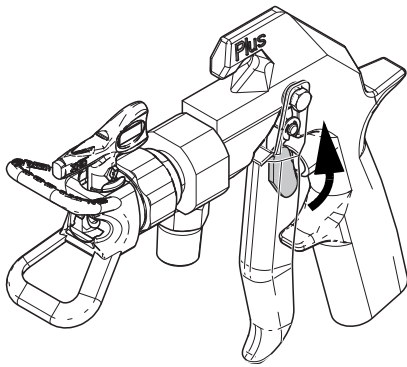

11. Close mix manifold material ball valves.

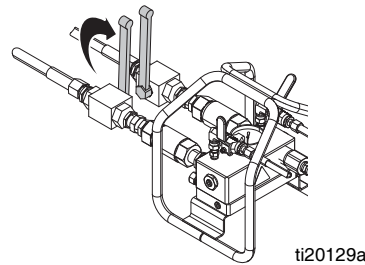

9. Hold a metal part of the gun firmly to a grounded metal pail. Trigger gun to relieve pressure in material hoses. Use a pail lid with a hole to dispense through. Seal around hole and gun with a rag to prevent splash back.

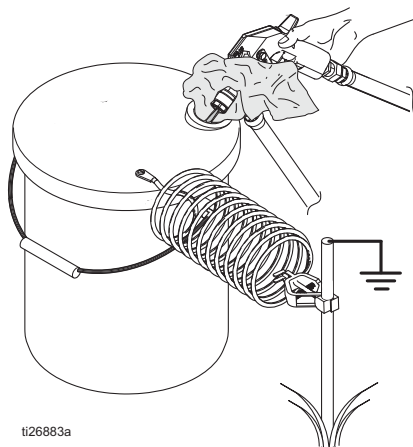

12. Perform **Flush Mixed Material** procedure on page 11 to prevent mixed material curing in the system and to relieve pressure in the solvent lines.
13. If the system will be shutdown for more than a few hours, fill pump A and B packing nuts with throat seal liquid (TSL™).

NOTE: Fluid pressure in the system is now relieved.

Flush Mixed Material



To avoid fire and explosion:

- Flush equipment only in a well-ventilated area.
- Ensure main power is off and heater is cool before flushing.
- Do not turn on heater until fluid lines are clear of solvent.

This procedure flushes out mixed material from system to prevent it from curing in the system.

NOTE: Pot life of the mixed materials in the system is much shorter than the dry time of dispensed epoxy because mixed material potlife or working time decreases with increased temperature.

Follow this procedure when you are finished spraying if the potlife of the mixed materials in the system could expire before you spray again.

1. If necessary, **Prime Flush Pump**. See operation manual for instructions.
2. Press  to stop the metering pumps.
3. Trigger gun into a waste container to relieve pressure then engage trigger lock.
4. Remove spray tip.
5. Close mix manifold ball valves.

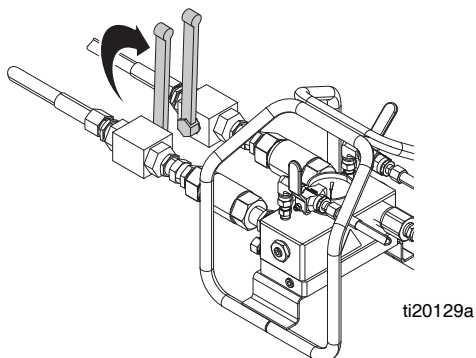

6. Open one of the flush ball valves on the mix manifold.
7. Disengage trigger lock and trigger gun into a grounded pail. Use a pail lid with a hole to dispense through. Seal around hole and gun with a rag to prevent splash back.
8. Open flush pump air supply valve (CB). Pull out and slowly turn flush pump air regulator (CG) clockwise to increase air pressure. Use lowest pressure needed to flush material out of hose.

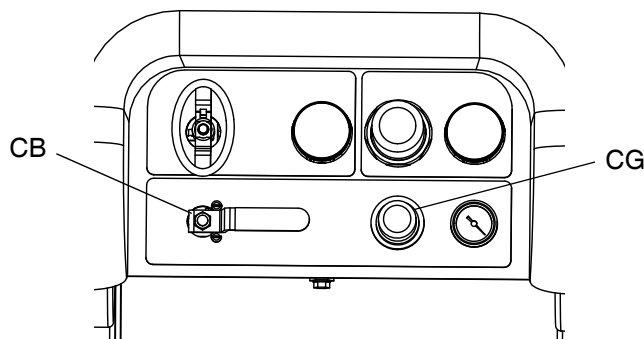

9. Continue dispensing until clean flushing fluid is dispensed.

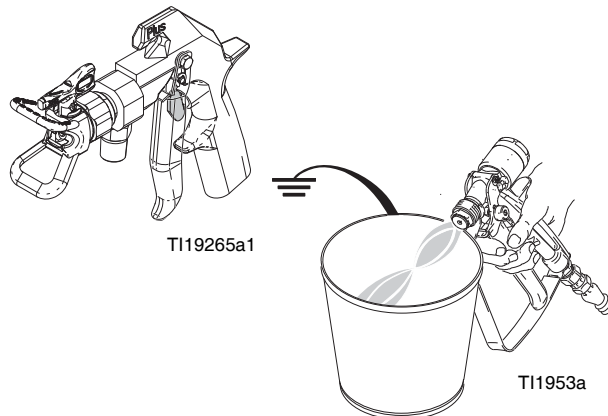

10. Close the open flush valve. Open the other flush valve. Continue dispensing long enough for any remaining mixed material.
11. Close flush pump air supply valve.

Flush Mixed Material

12. Trigger gun to relieve pressure in flush lines then engage trigger lock.

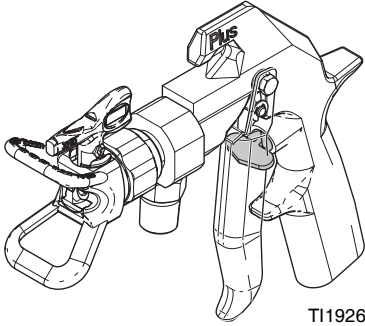

T119265a2

14. Use a rag and solvent to clean spray tip then reinstall on gun.

15. Remove the static mixer. Clean the mix element then re-install the mixer.

13. Close flush ball valves.

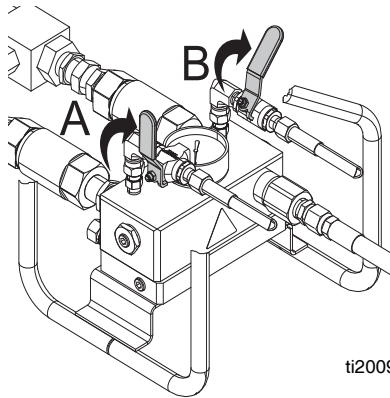

ti20095a

Troubleshooting

See sprayer Setup - Operation manual for troubleshooting details.

Repair

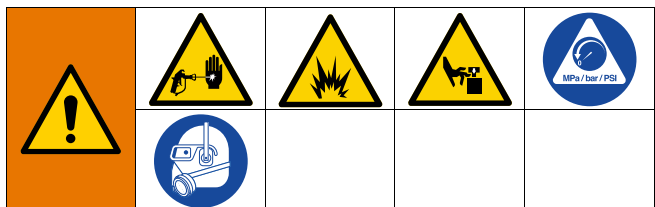

Follow **Pressure Relief Procedure** on page 9 if service time may exceed pot life time, before servicing fluid components, and before transporting sprayer.

Replace Air Filter Element

There are two air filters on all systems: the inlet air regulator filter on the air controls and the main air inlet manifold filter. Hazardous location systems also have a purge box air filter. Check filters weekly and replace element as needed.



To reduce the risk of serious injury, do not service air filter until air line is depressurized. Removing a pressurized air filter bowl could cause serious injury.

Control Air Regulator Filter

1. Close main air shutoff valve on air supply line and the main air shutoff valve (E).

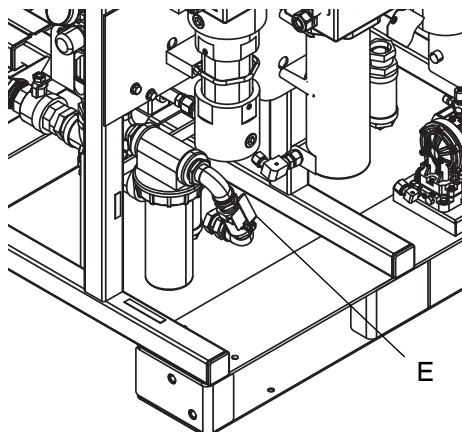

ti199526a1

2. Remove four nuts (21) and then remove front and rear shrouds (19, 20).

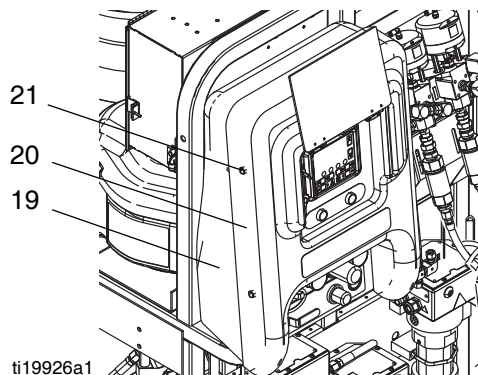

ti19926a1

3. Unscrew filter bowl from inlet air regulator (601d).
4. Remove and replace element.

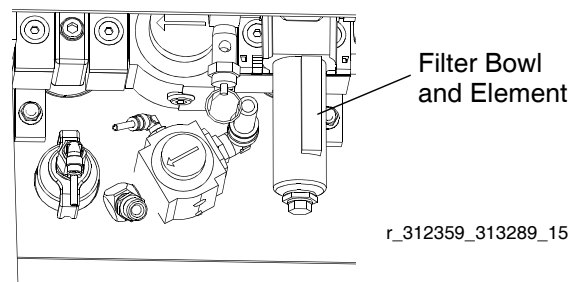
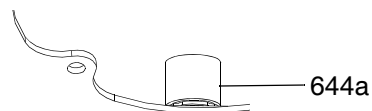

r_312359_313289_15

5. Screw filter bowl on securely.
6. Replace front and rear shrouds (19, 20) using four nuts (21).

Main Air Inlet Manifold Filter

1. Close the main air shutoff valve on the air supply line and the main air shutoff valve (E).
2. Unscrew filter bowl collar from main air inlet filter (14).

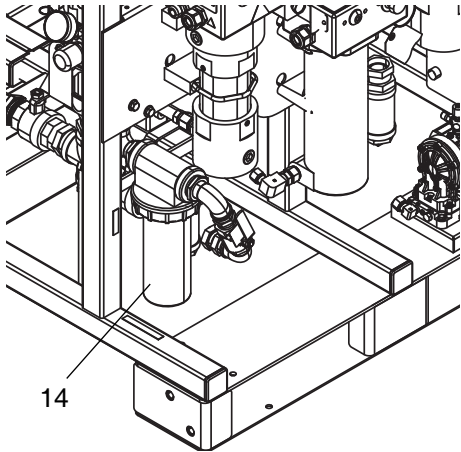

ti199526a1

3. Remove and replace filter element (701a). See **Air Filter (24P899)**, page 75.
4. Reassemble filter bowl.

Purge Box Air Inlet Filter

1. Close the main air shutoff valve on the air supply line and the main air shutoff valve (E).
2. Unscrew filter bowl collar from main air inlet filter (14).

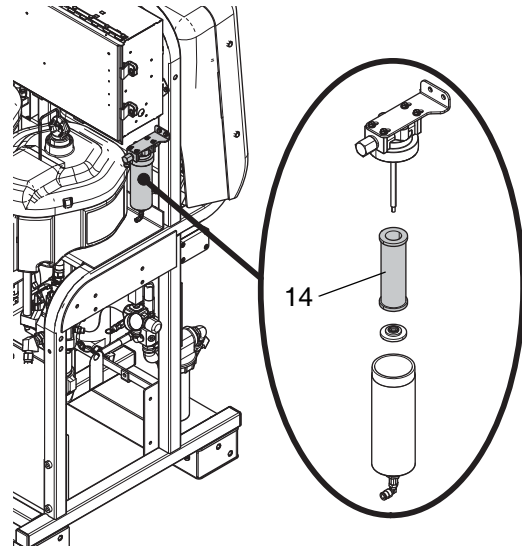

ti25946a

3. Remove and replace filter element.
4. Reassemble filter bowl.

User Interface/Control Box



Remove Shroud and Front Panel of Control Box

1. Close main air shutoff valve on air supply line and on system. Depressurize air line.
2. Disconnect power.
3. Remove four nuts (21) and then remove front and rear shrouds (19, 20).

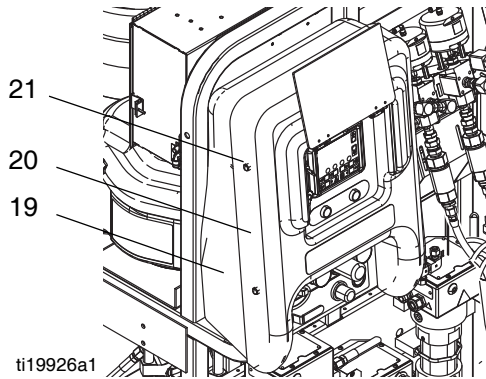

4. Remove four nuts (17); leave two nuts on left side of panel tight. Open front panel of control box (16). See FIG. 3.

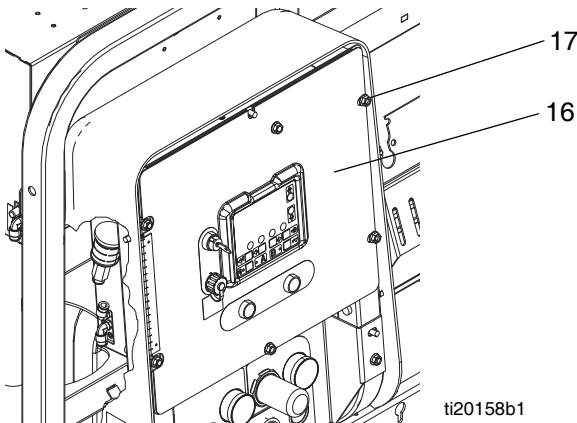

FIG. 3

Replace Single Solenoid Module

1. Remove Shroud and Front Panel of Control Box, see page 15.
2. Disconnect solenoid cable connector (542) from the solenoid (509a) being replaced. See **Electrical Schematics** if necessary. For hazardous location systems see **Sensors Schematic Control Box** on page 45. For non-hazardous location systems see **Sensors Schematic Control Box** on page 37.
3. Remove two screws (509b) from the solenoid being replaced then remove solenoid (509a). See FIG. 4.

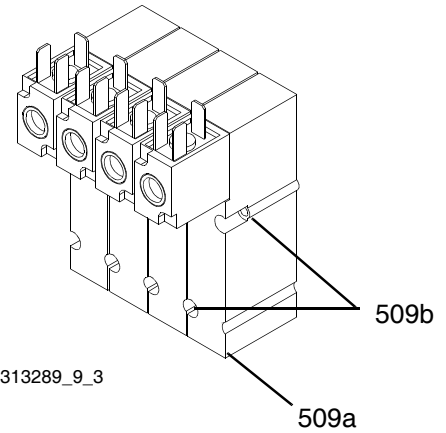
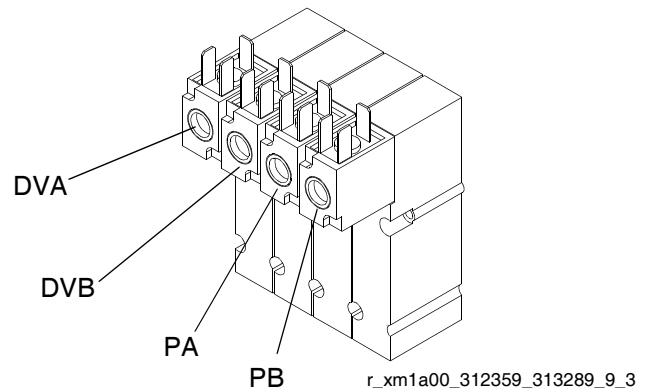

FIG. 4

4. Use screws (509b) to install new solenoid (509a).
5. Reconnect solenoid cable connectors (542).

NOTE: From left to right, solenoid functions are as follows:

- Dosing valve A (DVA) (normally open)
- Dosing valve B (DVB) (normally open)
- Pump A (PA) (normally closed)
- Pump B (PB) (normally closed)



Replace USB Module

1. Remove Shroud and Front Panel of Control Box, see page 15.
2. Disconnect CAN cables and USB cable from USB module (519).
3. Remove two mounting screws from USB module and remove module from base.

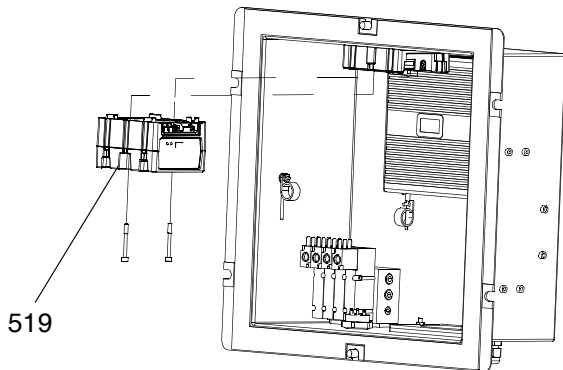

4. Follow steps in reverse order to install new USB module.
5. Load software. See **Replace USB Module**.

Replace Fluid Control Module (FCM)

NOTE: The USB module does not need to be removed prior to replacing the FCM.

1. Remove Shroud and Front Panel of Control Box, see page 15.
2. Remove all cables from FCM (518). Take note of cable locations.
3. Loosen four mounting screws (535).

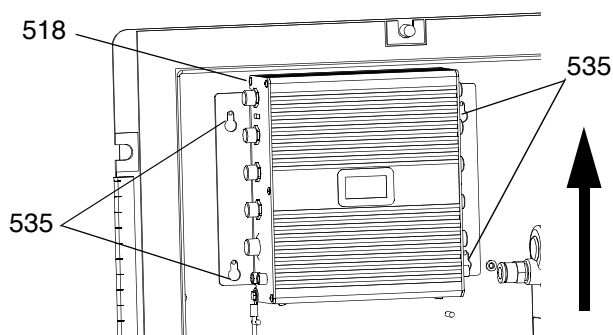

4. Slide FCM up and out of keyhole slots.
5. Follow steps in reverse order to install new FCM.

6. Load software. See **Load software**. See **Replace USB Module**.
7. Most of the system configuration is stored in the FCM. Use the display to change the configuration to the values in the old FCM. See XM PFP operation manual for instructions.

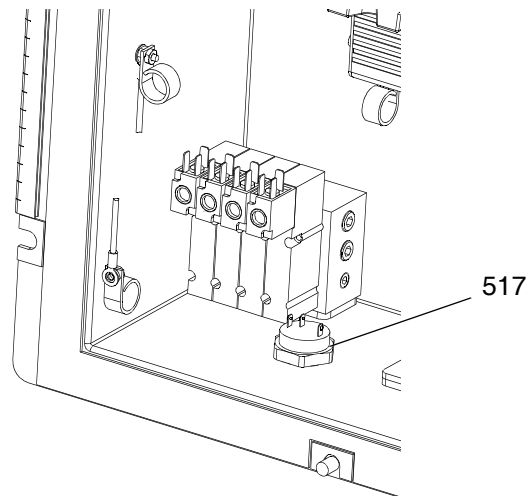

Replace Alarm

1. Remove Shroud and Front Panel of Control Box, see page 15.
2. Disconnect alarm wires from alarm (517).
3. Unscrew alarm (517) and replace.



4. Screw in new alarm. Reconnect alarm wires.
5. Reinstall front panel of control box and reinstall shrouds.

Display

				
To prevent fire and explosions, do not replace the display battery in a hazardous location.				

Replace Display Battery

NOTICE
To avoid damaging circuit board, wear a grounding strap.

1. Remove four screws (504f) then remove access cover (504e).

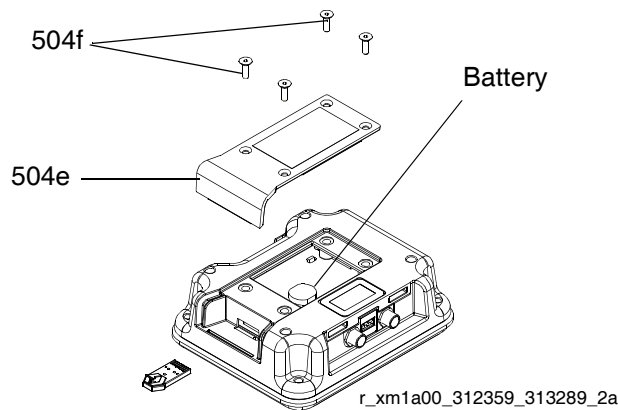

2. Use a flat head screwdriver to pry out old battery.

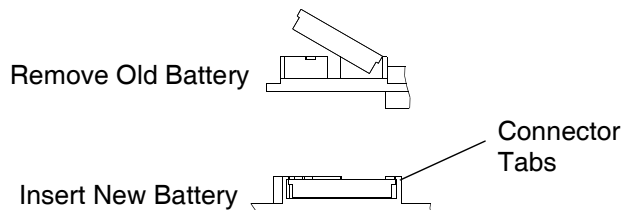

3. Replace with new battery. Ensure battery fits under connector tabs before snapping other end in place.

NOTE: Use only Panasonic CR2032 batteries for replacement.

4. Use screws (504f) to install access cover (504e).

Replace Display

Order display kit (504) for replacement.

NOTICE
To avoid damaging circuit board, wear a grounding strap.

1. Disconnect power.
2. **Remove Control Box Shrouds**, see page 23.
3. Disconnect CAN cable from display module.
4. Remove four screws (504f) from rear display panel (504c) while holding front display panel (504d) in place.

NOTE: To ease removal use clear tape to hold front display panel (504d) in place.

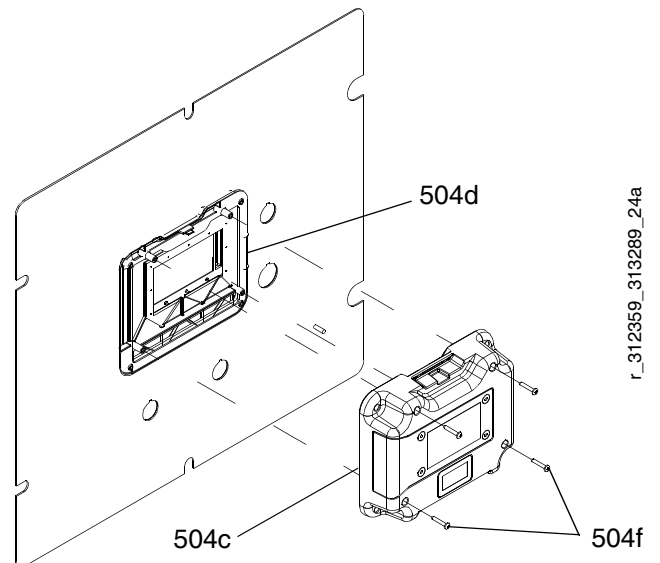

5. Remove rear display panel (504c) and disconnect display cable and key switch cable (539) from circuit board.

- Remove front display panel (504d) and gasket (504g).

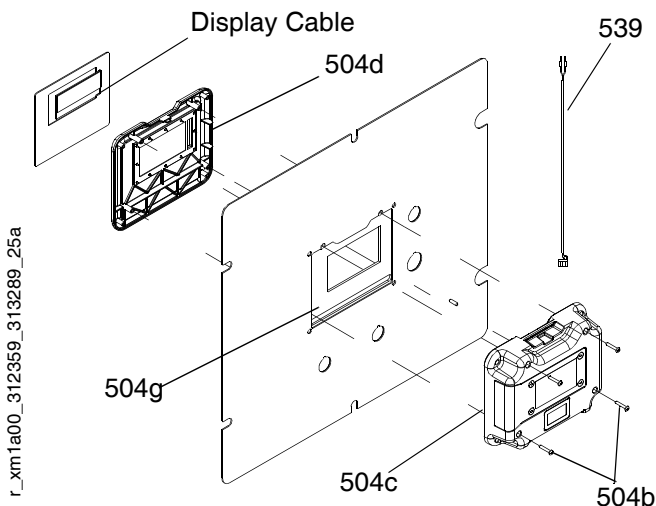

- Discard old display assembly.
- Place new front display panel (504d) and gasket (504g) on front panel of control box (16).

NOTE: To ease installation use clear tape to hold front display panel in place.

- Carefully connect display cables and key switch cable to new circuit board.
- Install new rear display panel (504c) and secure with four screws (504f). Ensure key switch cable protrudes from opening in top of display module.
- Install access cover and screws.
- Reconnect CAN cable to display module.
- Reconnect power.
- Load software. See **Upgrade Software**, page 18.
- Replace shroud.
- Configure system settings as they were set on old display. See XM PFP Operation manual for instructions.

Replace Front Panel

See **Replace Display**, page 17, for instructions.

Upgrade Software

- Download all USB logs. The new software will erase the USB logs. See operation manual for instructions to Download Data from USB.
- Turn off power to the system.
- Remove Shroud and Front Panel of Control Box**, see page 15.
- Remove four screws (504f) then remove access cover (504e).

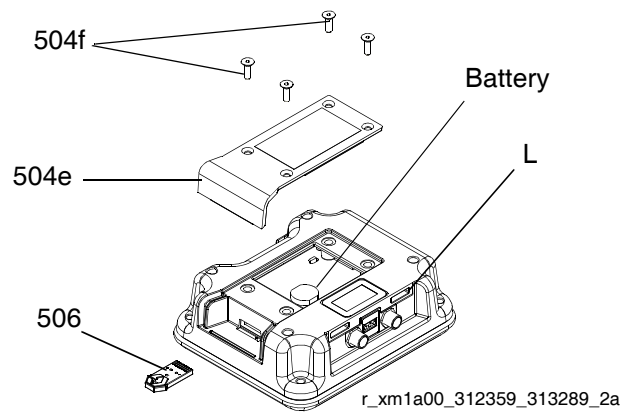



- Insert and press token (506) firmly into slot.

NOTE: There is no preferred orientation of token.

- Turn power on.
- The red indicator light (L) will flash until new software is loaded on the display module.
- All system modules will be automatically updated. See Graco Control Architecture Module Programming manual for details.
- Remove token.
- Reinstall shrouds and front panel.

Junction Box

				
All electrical wiring must be done by a qualified electrician and comply with all local codes and regulations.				

Replace High Power Temperature Control Module (HPTCM, ref. 435)

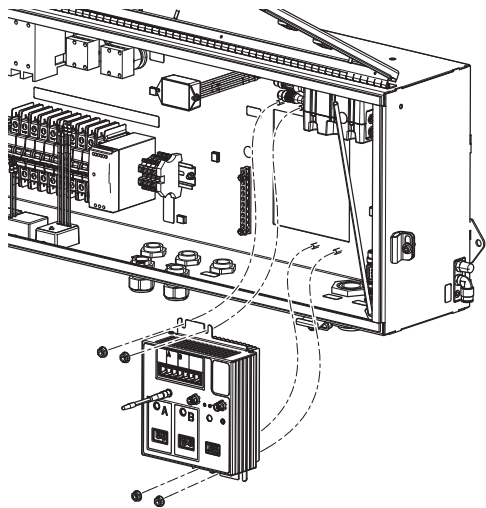

ti26762a

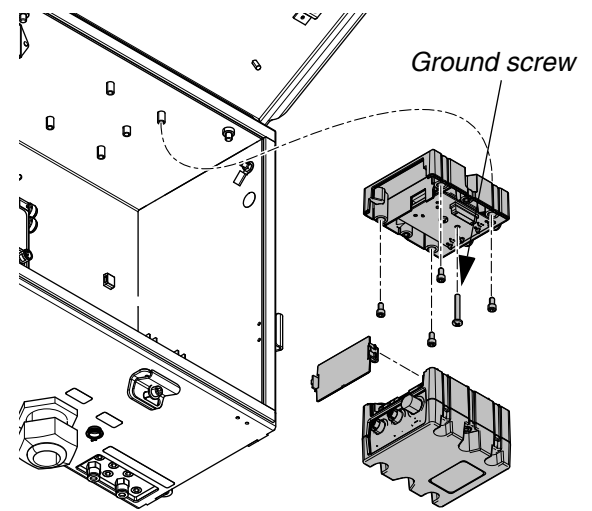

1. Turn system main power switch OFF.
2. Open junction box.
3. Unplug all connections on the HPTCM.
4. Remove screws securing HPTCM then remove HPTCM.
5. Install HPTCM and reattach HPTCM connections.
6. Close junction box.

Replace Fluid Control Module Cube (FCM3, ref. 408)





ti26761

1. Turn system main power switch OFF.
2. Open junction box.
3. Unplug all connections on the FCM3.
4. Remove two screws securing FCM3 then remove FCM3.

				
Center ground screw in the Fluid Control Module Cube must be used to avoid serious injury due to electric shock.				

5. Use screws to install FCM3.
6. Reattach FCM3 connections.
7. Close junction box.

Purge Box

				
All electrical wiring must be done by a qualified electrician and comply with all local codes and regulations.				

Replace High Power Temperature Control Module (HPTCM, ref. 1535)

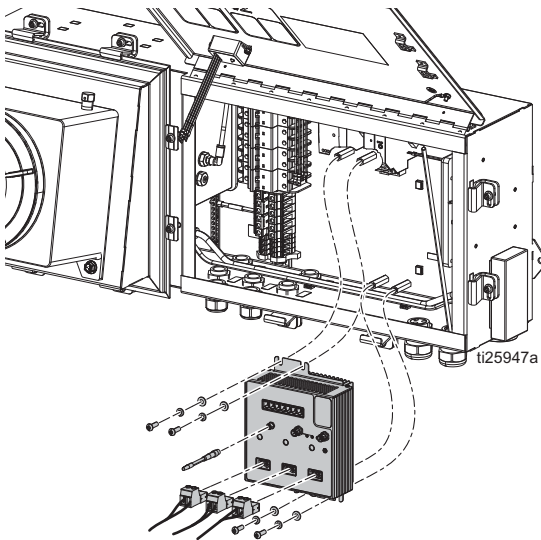

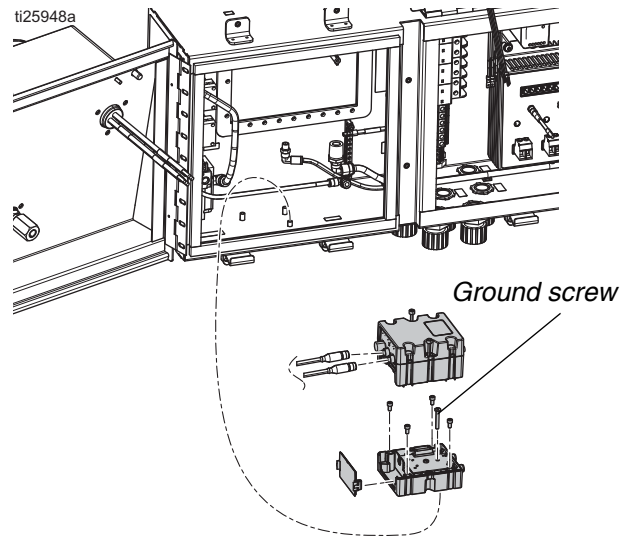

1. Turn system main power switch OFF.
2. Open purge box.
3. Unplug all connections on the HPTCM (1535).
4. Remove screws (1537) and washers (1536, 1537) securing HPTCM then remove HPTCM.
5. Install HPTCM (1535) and reattach HPTCM connections. See **Electrical Schematics**, page 33.
6. Close purge box.

Replace Fluid Control Module Cube (FCM3, ref.1547)



1. Turn system main power switch OFF.
2. Open the purge box and remove the purge controller (not shown) to access the FCM mounting screws. For removal instructions, see **Replace Purge Controller**, page 21.
3. Unplug all connections on the FCM3.
4. Loosen two screws securing FCM3 then remove FCM3.

				
Center ground screw in the Fluid Control Module Cube must be used to avoid serious injury due to electric shock.				

5. Use screws to install FCM3.
6. Reattach FCM3 connections.
7. Reinstall purge controller. See **Replace Purge Controller**, page 21.
8. Close purge box.

Replace Purge Controller

NOTE: For hazardous location systems only.

1. Turn system main power switch OFF.
2. Disconnect four air tubes from the purge controller (1504).
3. Remove seven mounting screws (S), door (D), and door gasket (G). Remove the purge controller (1504) and gasket (1549) from the back of the purge box.
4. Install new gasket (1549) on purge controller (1504), then insert the purge controller (1504) and new gasket (1549) from the back of the purge box. Connect to frame with mounting screws (S).
5. Connect air tubes to purge controller (1504) fittings.

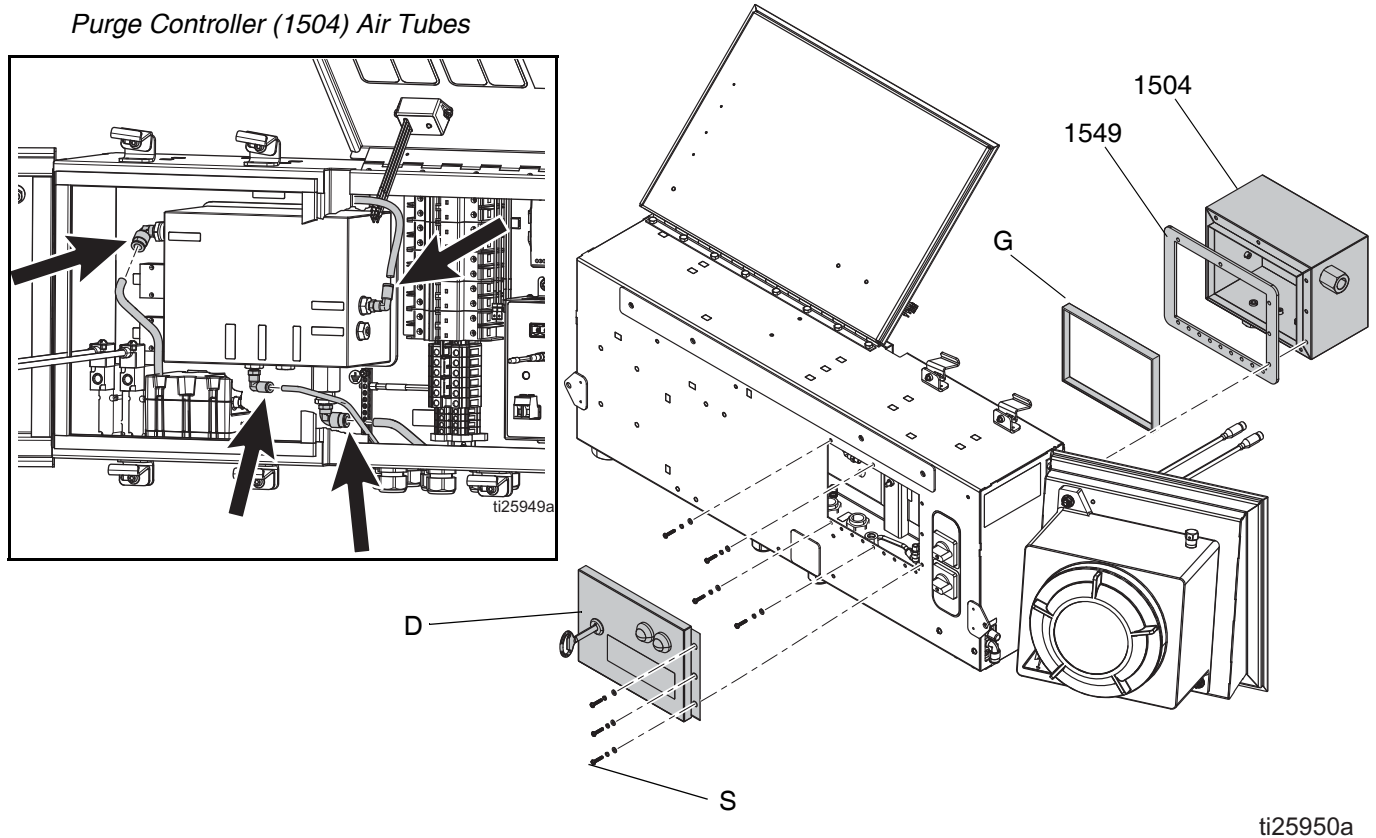

Multi-zone 3 Channel Barrier

1. Turn main power off.
2. Open purge box.
3. Disconnect CAN cables, ground wire (1527), and air tubing from fittings.

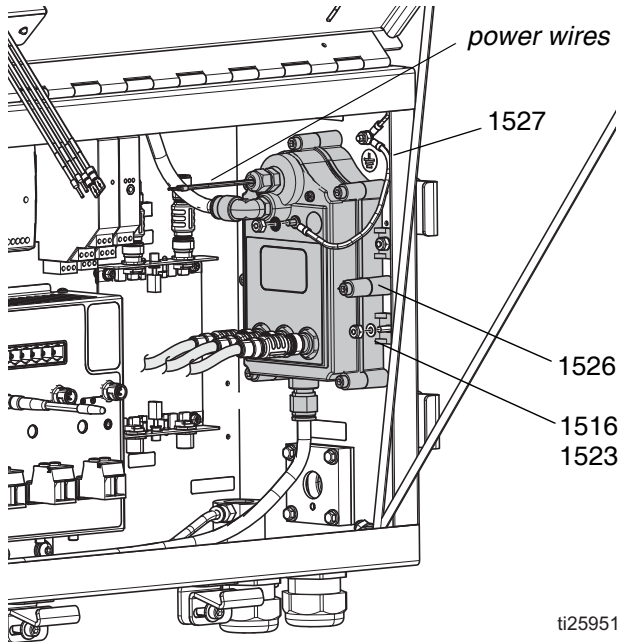

4. Disconnect red and black power wires from terminal blocks. See **CAN Network and DC Power Schematic**, page 43.
5. Remove nuts (1516) and washers (1523) and multi-zone 3 channel barrier module (1526).
6. Secure a new multi-zone 3 channel barrier module (1526) in purge box with nuts (1516) and washers (1523).
7. Reconnect the CAN cables, air tubing, ground wire, and power wiring.
8. Close purge box.

Air Controls

Remove Control Box Shrouds

1. Close main air shutoff valve on air supply line and on system. Depressurize air line.
2. Remove four nuts (21) and then remove front and rear shrouds (19, 20).

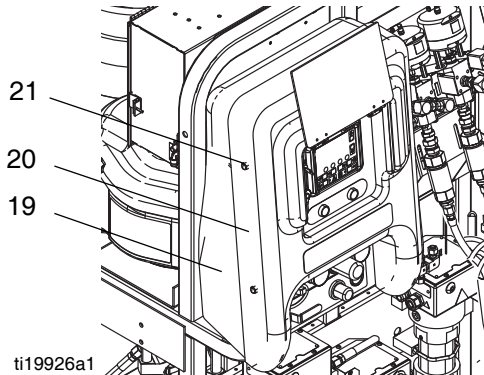

Remove Air Control Assembly (18)

1. **Remove Control Box Shrouds.**
2. Disconnect air motor air lines and system air line.
3. Remove four nuts (17) from front of air controls (18). See FIG. 5, page 24.
4. Pull out assembly (18).
5. Follow steps in reverse order to reinstall air control assembly.

Replace Flush Pump Air Ball Valve (626)

1. **Remove Air Control Assembly (18).**
2. Remove two nuts (630) from front of air control bracket (619). See FIG. 5, page 24.
3. Disconnect air line (632) running to ball valve assembly (626).
4. Replace with new ball valve assembly. See part number shown in the **System Air Controls Module (255761)** section beginning on page 63.
5. Follow steps in reverse order to reassemble.

Replace Flush Pump Air Regulator (625)

1. **Remove Air Control Assembly (18).**
2. Remove regulator nut (631), and disconnect air lines (632, 633) running to regulator (625). See FIG. 5 on page 24.
3. Remove regulator assembly and replace with new. See part number shown in the **System Air Controls Module (255761)** section beginning on page 63.
4. Follow steps in reverse order to reassemble.

Replace System Air Regulator (645)

1. **Remove Air Control Assembly (18).**
2. Remove regulator nut and disconnect system air line. See FIG. 5, page 24.
3. Remove screws from quick clamps and open clamps (642) at hinge.
4. Remove regulator assembly (645) and replace with new.
5. Follow steps in reverse order to reassemble.

Replace Solenoid Inlet Air Regulator (644)

1. Remove Control Box Shrouds.
2. Remove Air Control Assembly (18).
3. Disconnect air line from air regulator (644).
4. Remove gauge (616) from block (643).
5. Remove screws from quick clamps (642) holding air regulator assembly (644) in place.
6. Open clamps (642) at hinge and pull apart from block (643).
7. Remove regulator assembly (644) and replace with new.

8. Follow steps in reverse order to reassemble.
9. Set new air pressure regulator to at least 80-85 psi (0.55-0.58 MPa, 5.5-5.8 bar).

Replace Purge Box Inlet Air Regulator (160)

1. Remove Control Box Shrouds.
2. Disconnect air line from regulator (160).
3. Remove fittings (177, 161). Remove regulator assembly (160).
4. Follow steps in reverse order to reassemble.

* Hazardous location only.

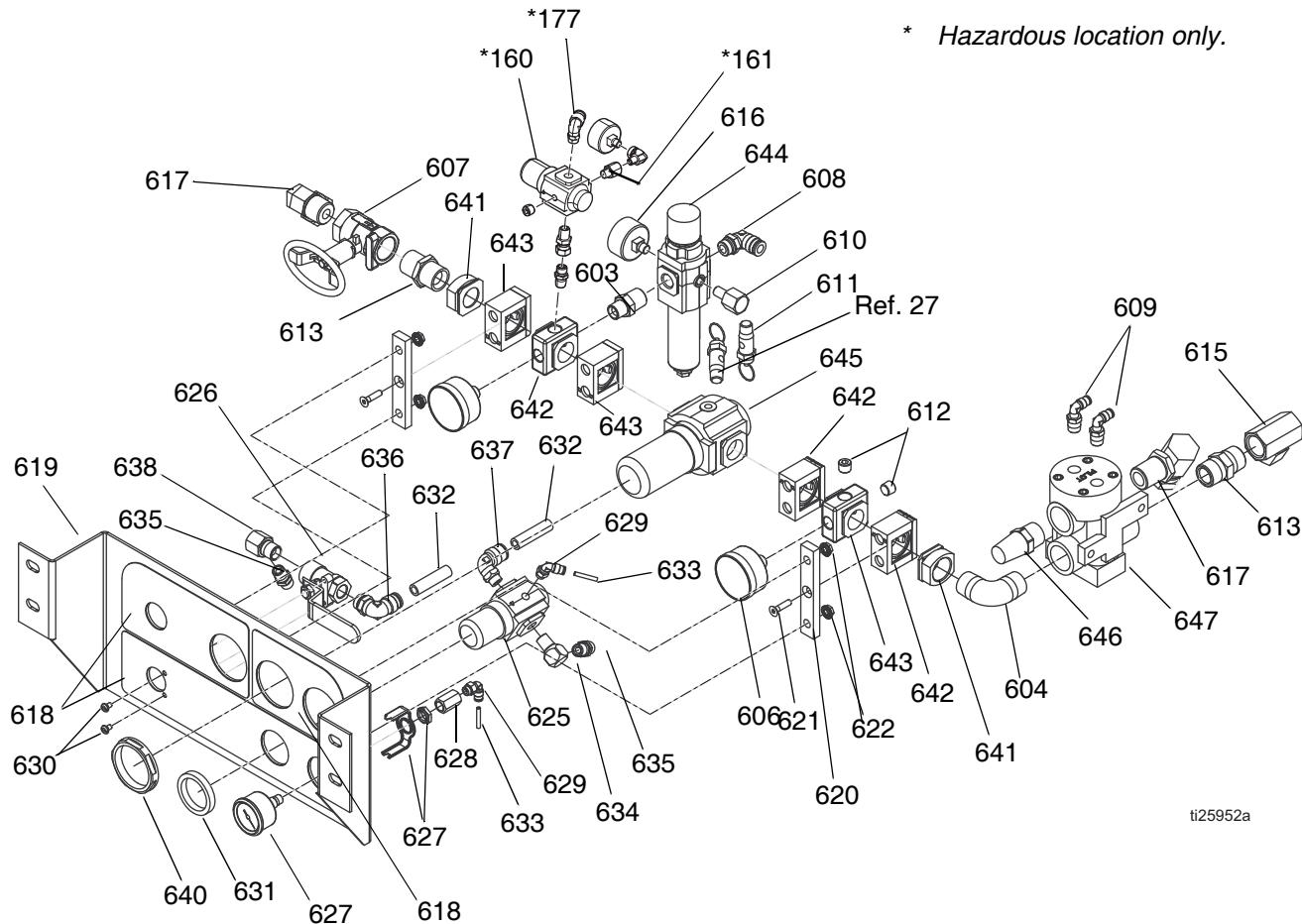

FIG. 5: Air Control Assembly (18)

Dosing Valve Assembly



1. Follow **Pressure Relief Procedure**, page 9.
2. Disconnect all fluid lines from dosing valves (28 or 29). See FIG. 6.
3. Remove two bolts (31) securing dosing valve to bracket.
4. Unscrew dosing valve nipple fitting (36 or 37) from dosing valve outlet.
5. Disconnect pressure sensor (831) from dosing valve. See page 76.
6. Remove dosing valves.
7. See **Ratio Control Valve Assemblies (28, 29)** on page 76 for disassembly illustration.
8. Follow steps in reverse order to reassemble dosing valve assembly. See **Ratio Control Valve Assemblies (28, 29)** on page 76 for assembly illustration and specifications.

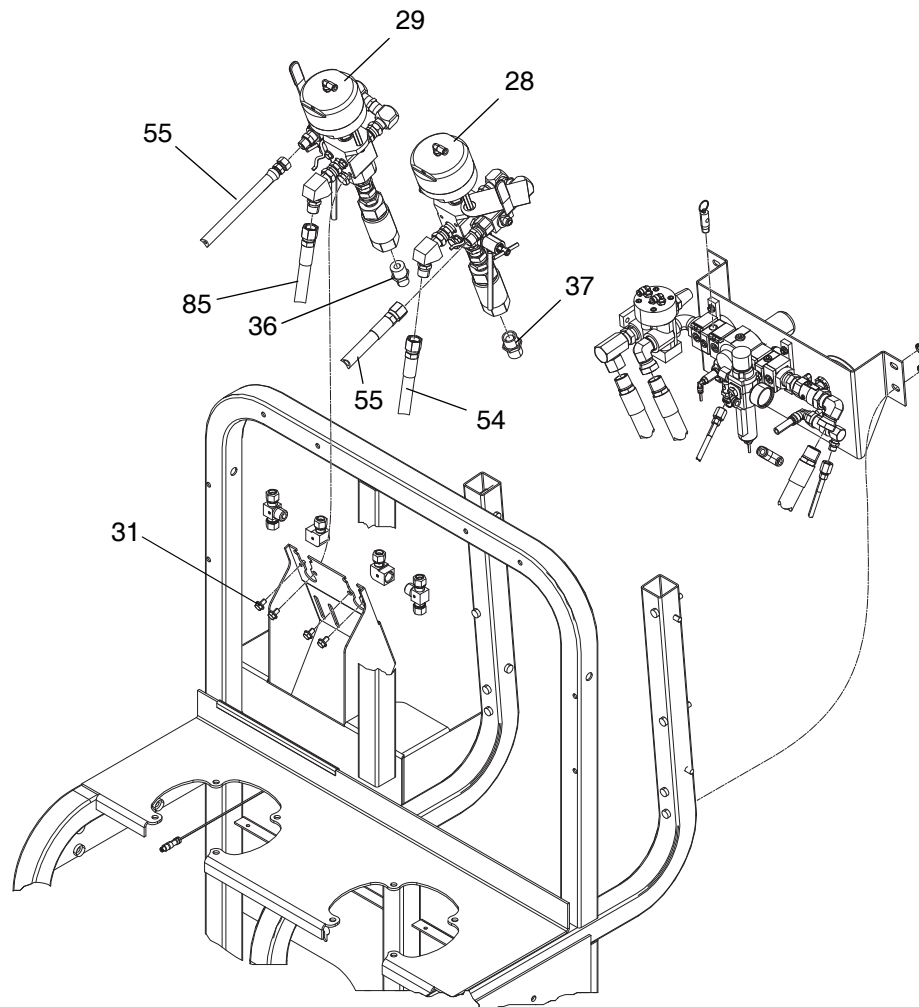

FIG. 6

Sensors



Replace Fluid Pressure Sensor

1. Close main air shutoff valve on air supply line and on system.
2. Follow **Pressure Relief Procedure**, page 9.
3. Open control box cover. See **User Interface/Control Box**, page 15.
4. Disconnect pressure sensor (831) from dosing valve. See **Ratio Control Valve Assemblies (28, 29)** on page 76.
5. Disconnect other end of pressure sensor (831) from FCM (507). See **Control Box (16)** on page 73.
6. Replace with new fluid pressure sensor, and reconnect pressure sensor to FCM and dosing valve.

Hose Bundle Temperature Sensor (93)

1. Disconnect the M8 cable connection going into the hose bundle.
2. Open up the hose bundle wrap and insulation until sensor (93) can be removed easily without pulling on cable.
3. Remove sensor (93).

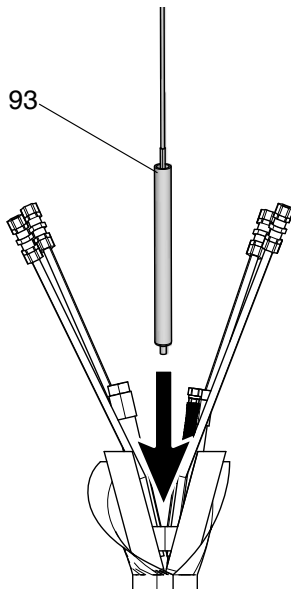

4. Push new sensor fully into insulated portion of hose bundle.
5. Close insulation and hose bundle wrap and re-tape. Ensure there is no stress on the cable.
6. Reconnect M8 connector.

Replace Temperature (RTD) Sensors

This procedure applies to:

- Tank sensors mounted in the side of each tank near the bottom (209). See parts illustration on page 58.
- Glycol heater for hose outlet manifold sensor (100). See parts illustration on page 54.

1. **Close main air shutoff valve** on air supply line and on system.
2. Follow **Pressure Relief Procedure**, page 9.
3. Disconnect the M8 cable connection.
4. Loosen the compression nut. Pull sensor straight out of fitting (82 or 208).
5. Remove fitting (82 or 208).

NOTE: The compressed ferrule cannot be removed from the sensor. A new compression fitting must be used.

6. Apply thread sealant then replace compression fitting (82 or 208). Tighten fitting in place.
7. Position sensor (100 or 209):
 - **Tank:** Insert sensor, leaving 5/8 in. (15.8 mm) sheath outside fitting.
 - **Heater manifold:** Insert sensor, leaving 1/8 in. (3.2 mm) sheath outside fitting.
8. Install compression nut on sheath hand-tight then tighten an additional 3/4 turn.

Pump Assembly (System Module)



Prior to servicing the pump assembly you must first remove either the entire pump assembly or the displacement pump and air motor individually.

Remove Pump Assembly

1. Follow **Pressure Relief Procedure**, page 9.
2. Close ball valve at metering pump inlet.
3. Disconnect fluid inlet line from the displacement pump. Leave line connected to the tank.
4. Disconnect air motor.
 - a. Disconnect sensor cable, air line, and ground wire from air motor.
 - b. Remove mounting screws (5) and washers (4) holding air motor (2 or 3) to mounting bracket. See FIG. 7 on page 28.
5. Use lift ring on air motor to remove pump assembly.



To avoid serious injury from falling objects caused by the lift ring breaking, do not lift pump assembly by the lift ring when the total weight of the pump assembly exceeds 550 lb (250 kg).

6. Refer to Xtreme Displacement Pump manual 311762 to service or repair the displacement pump. Refer to your XL Air Motor manual to service or repair the air motor.
7. Reconnect ground wire and sensor cable. Follow steps in reverse order to reinstall pump assembly.

Remove Displacement Pump

Follow these instructions for removing only the displacement pump; the air motor will remain installed.

1. Follow **Pressure Relief Procedure**, page 9.
2. Close ball valve on tank outlet.
3. Disconnect fluid inlet line from the displacement pump. Leave line connected to the tank.
4. Remove clip (2b), and slide coupling cover (2c) up to remove coupling (2a).

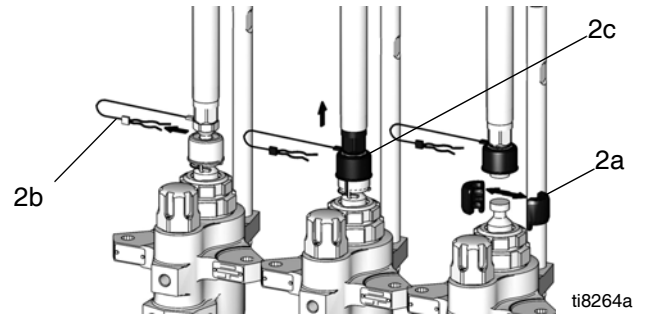

5. Use a wrench to hold the tie rod flats to keep the rods from turning. Unscrew the nuts (2e) from the tie rods (2d) and carefully remove the displacement pump (2f).

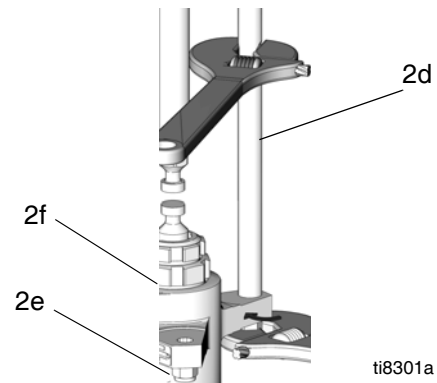

6. Refer to the Xtreme Displacement Pump manual 311762 to service or repair the displacement pump.
7. Follow steps in reverse order to reinstall displacement pump.

Remove Air Motor

1. Follow **Pressure Relief Procedure**, page 9.
2. Disconnect displacement pump from air motor. See steps 2 and 3 under **Remove Displacement Pump**, page 27.
3. Disconnect sensor cable, air line, and ground wire from air motor.
4. Remove mounting screws (5) and washers (4) holding air motor (2 or 3) to mounting bracket.

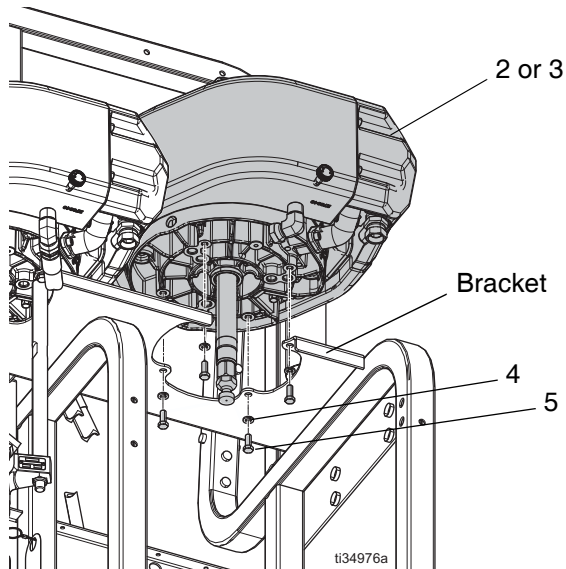

FIG. 7

5. Refer to your XL Air Motor manual to service or repair the air motor.
6. Reconnect ground wire and sensor cable. Follow steps in reverse order to reinstall air motor.

Pail Feed RAM Pump Assembly (Feed Module)

NOTE: See Pail Feed RAM Pump assembly (227) in parts breakdown beginning on page 58.

See your Supply Systems manual for service and repair instructions and parts.

Flush Pump



1. Follow **Pressure Relief Procedure**, page 9.
2. Disconnect pump inlet line (154) and air lines (57, 60) from flush pump.
3. Disconnect fluid outlet line.
4. Remove four screws (153) that attach flush pump (8) to bracket (152) and remove flush pump.

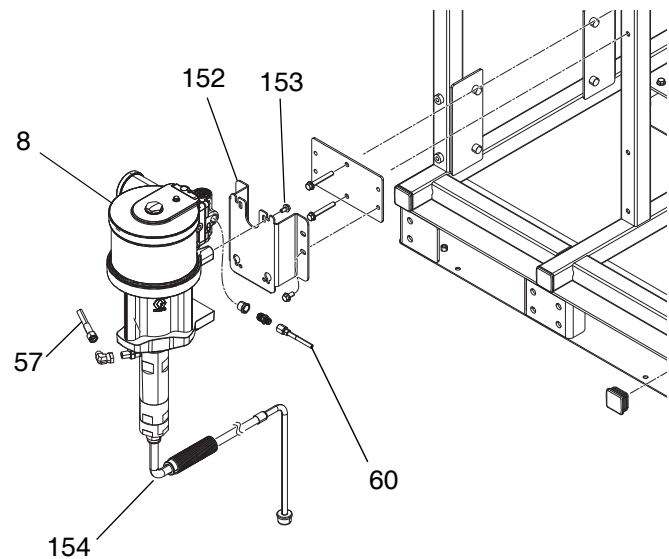

5. Refer to your Merkur Pump Assembly manual to service or repair flush pump 257463.
6. Follow steps in reverse order to reinstall flush pump.

Heaters

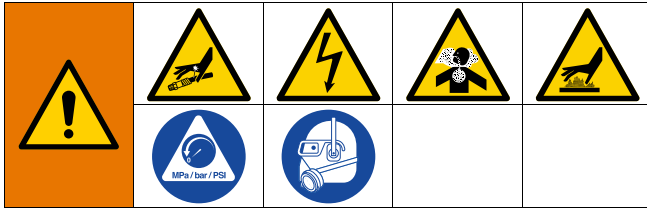

See applicable heater manual for wiring, repair, and parts information. See **Warnings** on page 4.

Service and Repair

1. Wait for heaters to cool before beginning to repair the heaters.
2. Follow **Pressure Relief Procedure**, page 9.
3. Turn off power.
4. Disconnect fluid lines and electrical wiring from fluid heater.
5. Refer to heater manual to service or repair heater.
6. Reconnect fluid lines and electrical wiring.

Replace

1. Wait for heaters to cool before replacing the heaters.
2. Follow **Pressure Relief Procedure**, page 9.
3. Turn off power.
4. Disconnect fluid lines and electrical wiring from fluid heater.
5. **System Module Heaters:** See FIG. 8. Loosen four mounting screws, lock washers, and plain washers on back of heater (12 or 13) that secure it to the system frame. Slide heater up and remove from mounting plate.
6. **Feed Module Heaters:** See page 59. Remove 2 screws (224) then remove heater (226) from feed module frame.
7. Replace heater. Follow steps in reverse order to install new heater.

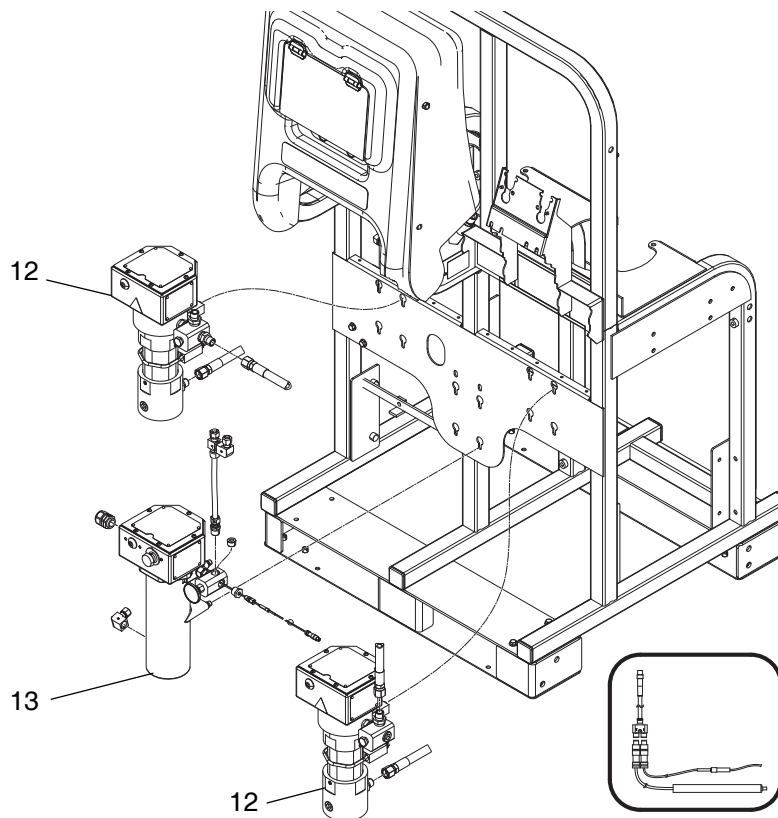

FIG. 8: Heaters on System Module

Replace Radar Level Sensor



NOTE: Order radar level sensor kit 26C587. See **Feed Modules** on page 58 for kit contents.

NOTE: Tank level sensors changed in 2014. The old sensors were red. The new sensors are blue. The blue sensors can be used as direct replacements for the red sensors.

1. With the tank empty, close the tank air supply ball valve then open the valve on the tank lid to de-pressurize the tank. See FIG. 9.

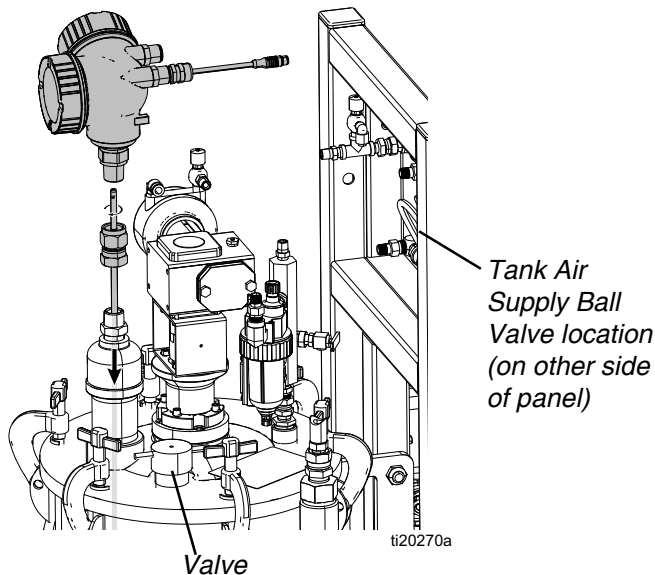

FIG. 9: Level Sensor Installation

2. Disconnect cable at the bottom of the feed module.
Always use the new cable supplied with the sensor. It has different connections than the old sensor.
3. Disconnect 3/4 in. union that holds the level sensor on top of the tank.
4. Pull the old sensor straight up out of the tank.
5. Remove plugs from new sensor and discard plugs. Move fittings from old sensor to new sensor.
6. If the sensor rod was removed for shipping, apply blue thread-lock to the threads in the end of the rod.

7. Feed the rod into the sensor head and screw the threaded end into the sensor head.
8. Use a wrench to hold the 3/8 in. flats on the sensor rod.
9. Tighten to approximately 25 - 30 in-lb (2.8 - 3.4 N•m). Do not over-tighten.
10. Reconnect sensor cable.
11. See **Set Up a New Radar Level Sensor**, page 31.

Set Up a New Radar Level Sensor

Level sensors need to have three settings setup after installing on the tank of the PFP machine. The tank must be empty, or the level needs to be at least below the bottom of the installed probe with the tank cover closed.

1. Open the sensor head cover over the display:
 - a. Loosen the securing clamp with an Allen wrench (if clamp is present).
 - b. Unscrew the round cover and pull away.

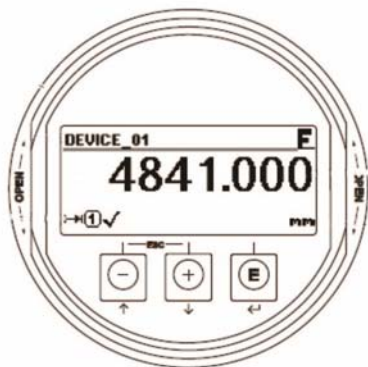
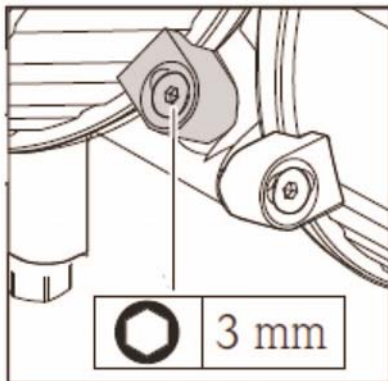

ti24380a

NOTE: Use the operating keys to navigate within the operating menu and to select options from a list.

Key	Meaning
	<p>“Minus” Key</p> <ul style="list-style-type: none"> In a selection list, this key will move the selection bar upward. In an input matrix, this key will move the selection bar backward.
	<p>“Plus” Key</p> <ul style="list-style-type: none"> In a selection list, this key will move the selection bar downward. In an input matrix, this key will move the selection bar forward.
	<p>“Enter” Key</p> <ul style="list-style-type: none"> Opens the marked sub-menu or parameter. Confirms a changed parameter value.
	<p>“Escape” Key combination (press keys simultaneously)</p> <ul style="list-style-type: none"> Closes a parameter without accepting the changes. Quits the current menu layer and returns to the next higher layer.

2. Turn power on the machine. Set **EMPTY CAL**, then **FULL CAL**, then do a mapping of the Empty Tank.
3. Set **EMPTY CAL** to .666 meters:
 - a. Press **E**, then **+**, **+**, to get to **Set Up**. Then press **E** to get to **EMPTY CAL**, then press **E**.
 - b. Press **+** until decimal point (.) appears, then press **E**.
 - c. Press **+** until 6 appears, then press **E**.
 - d. Press **+** until 6 appears, then press **E**.
 - e. Press **+** until 6 appears, then press **E**.
 - f. Press and hold **E** until the hourglass appears, then release.

4. Set **FULL CAL** to 0.418 meters.
 - a. Press **+** to get to **FULL CAL**, then press **E**.
 - b. Press **+** until decimal point (.) appears, then press **E**.
 - c. Press **+** until 4 appears, then press **E**.
 - d. Press **+** until 1 appears, then press **E**.
 - e. Press **+** until 8 appears, then press **E**.
 - f. Press and hold **E** until the hourglass appears, then release.
5. Map **EMPTY TANK**.
 - a. Press **+** to get to **MAPPING**, then press **E**.
 - b. Press **E** to get to **CONFIRM DISTANCE**.
 - c. Press **+** until **TANK EMPTY** appears, then press **E**.
 - d. Press **+** under the check mark to confirm, **END OF SEQUENCE** will appear. Press and hold **E** until the hourglass appears, then release.
 - e. You are now finished. Press **+** and **-** together until the hourglass appears, then release.
6. The transmitter display should show nothing in the tank. Check the level display on the PFP machine control. It should also show the tank as empty.
7. These settings can now be locked from display control so they will not be inadvertently changed.
8. Set display to lock ON:
 - a. Turn display counter-clockwise to release it as shown below (2).
 - b. Set the dip switch to the lock position as shown below (3).
 - c. Replace display (4).
 - d. Replace screw on lid (5).
 - e. Engage cover securing clamp.

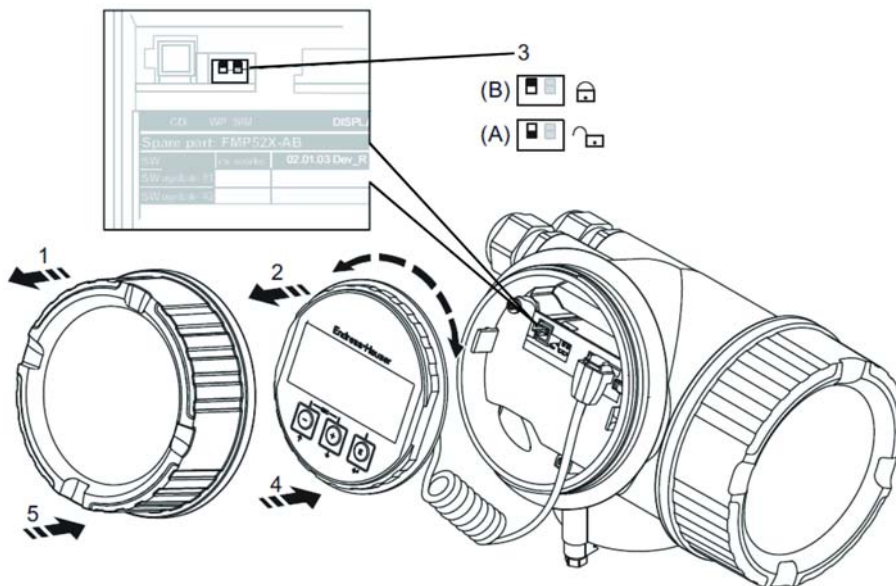

Electrical Schematics

Non-Hazardous Location Schematic

AC Power Schematic

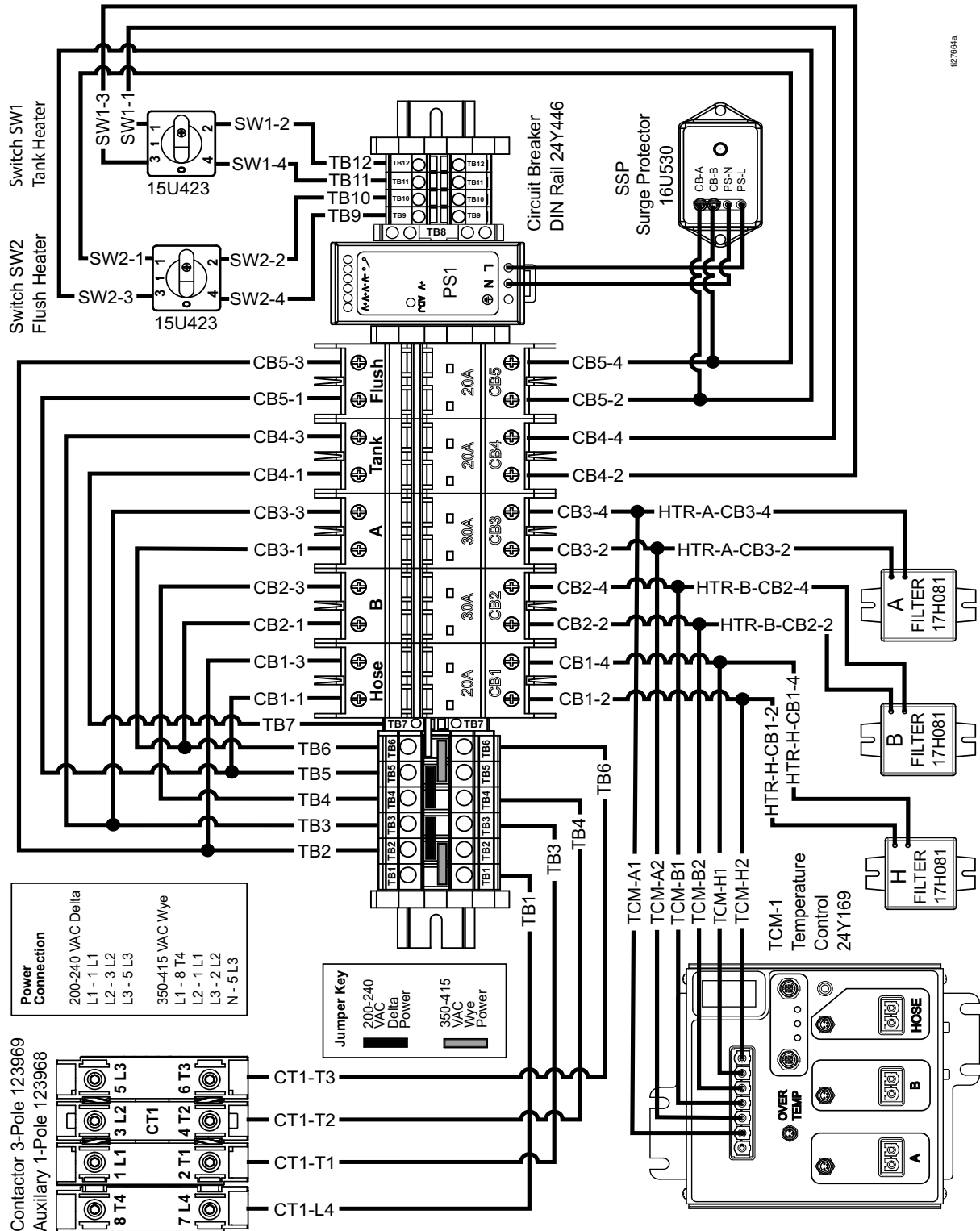

127664a

Heater Schematic

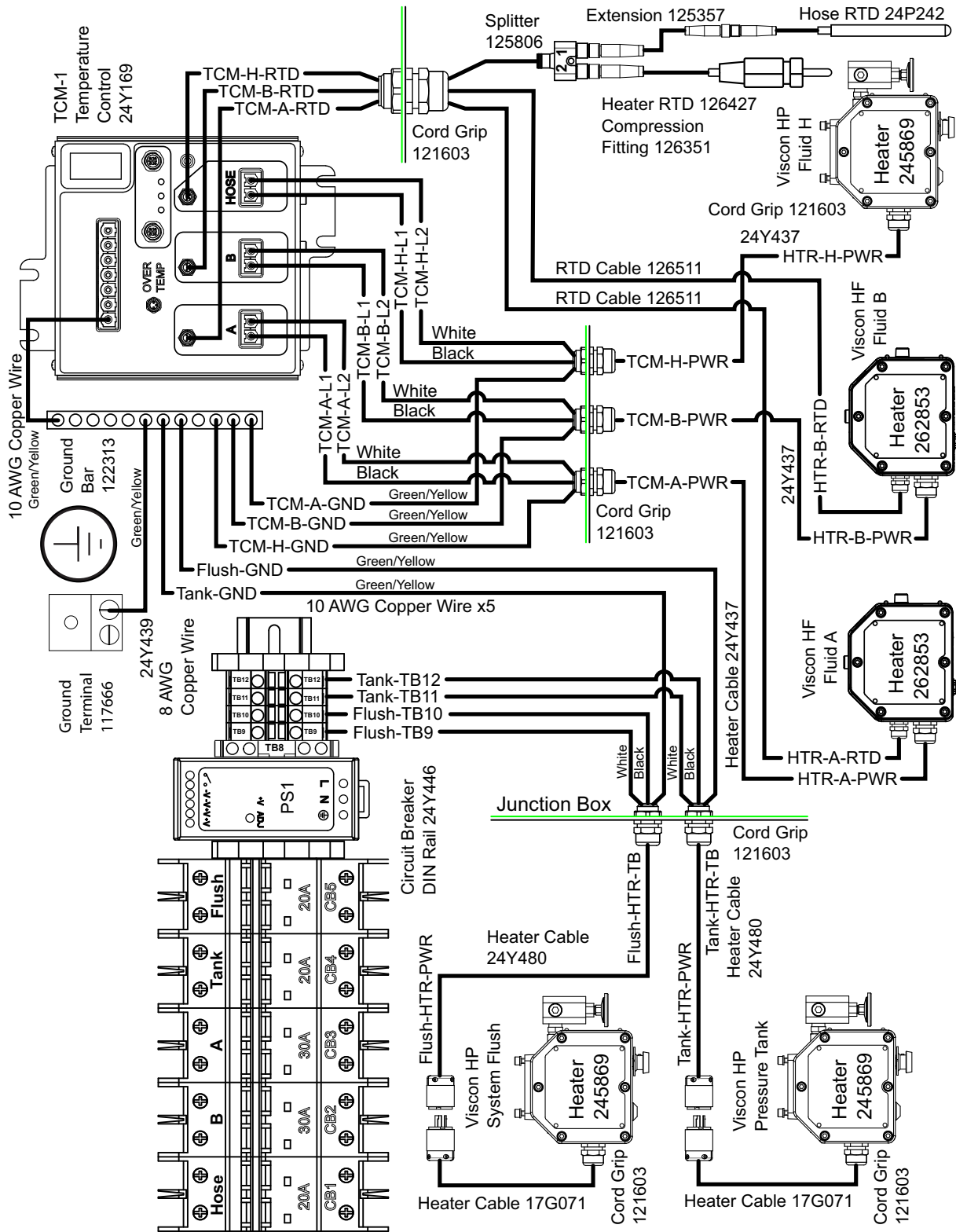

CAN Network Schematic

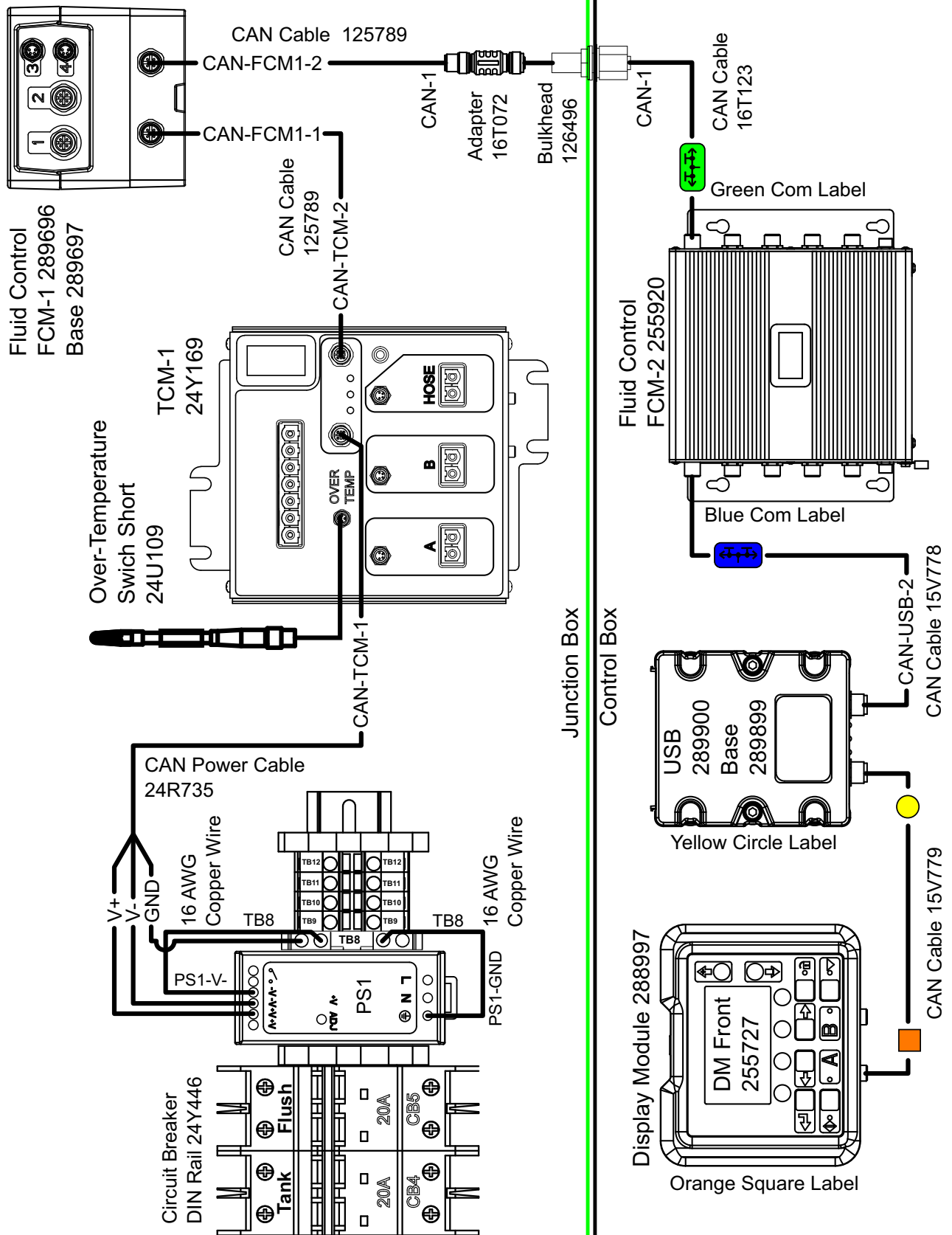

Sensor Schematic Junction Box

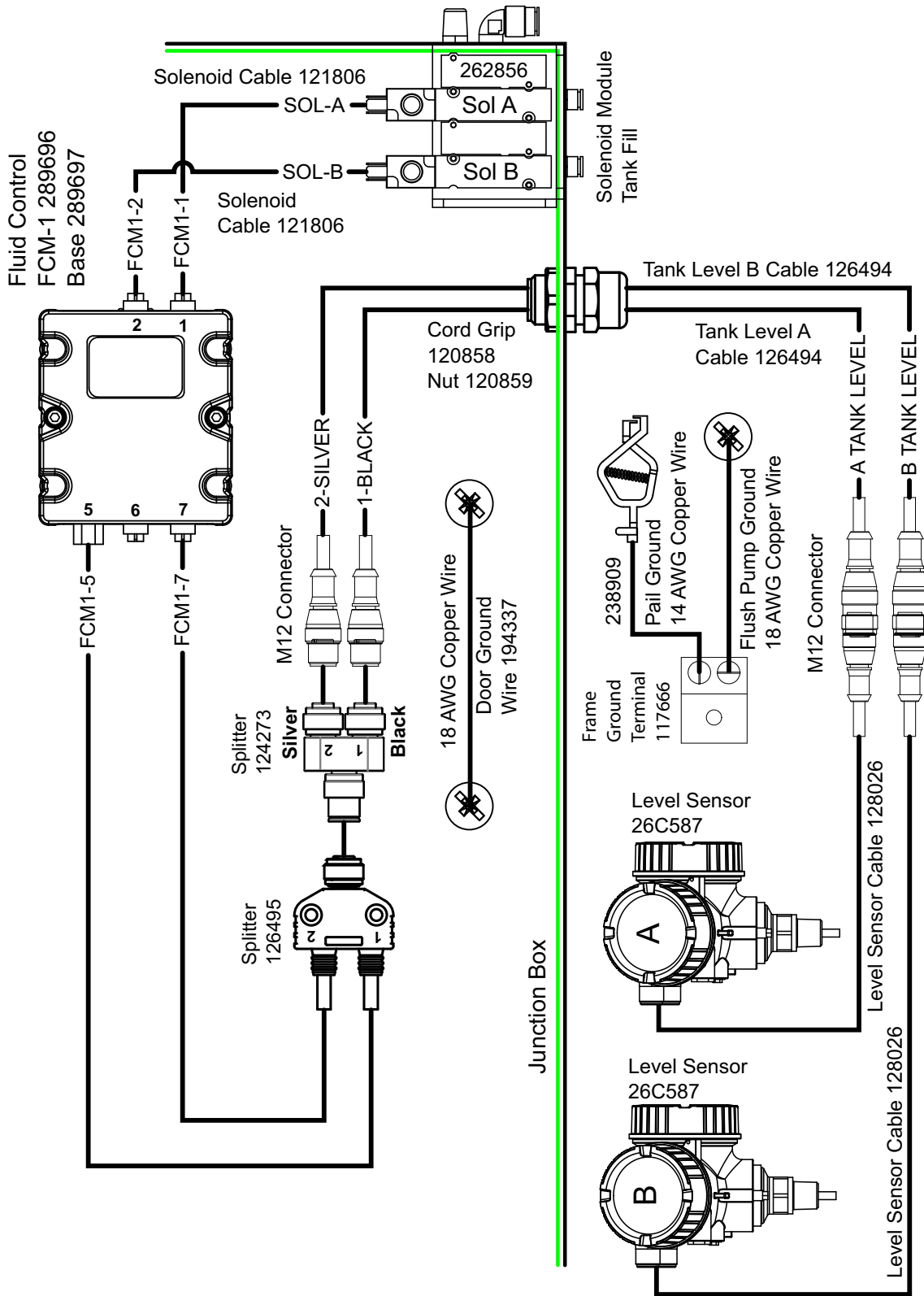

Sensors Schematic Control Box

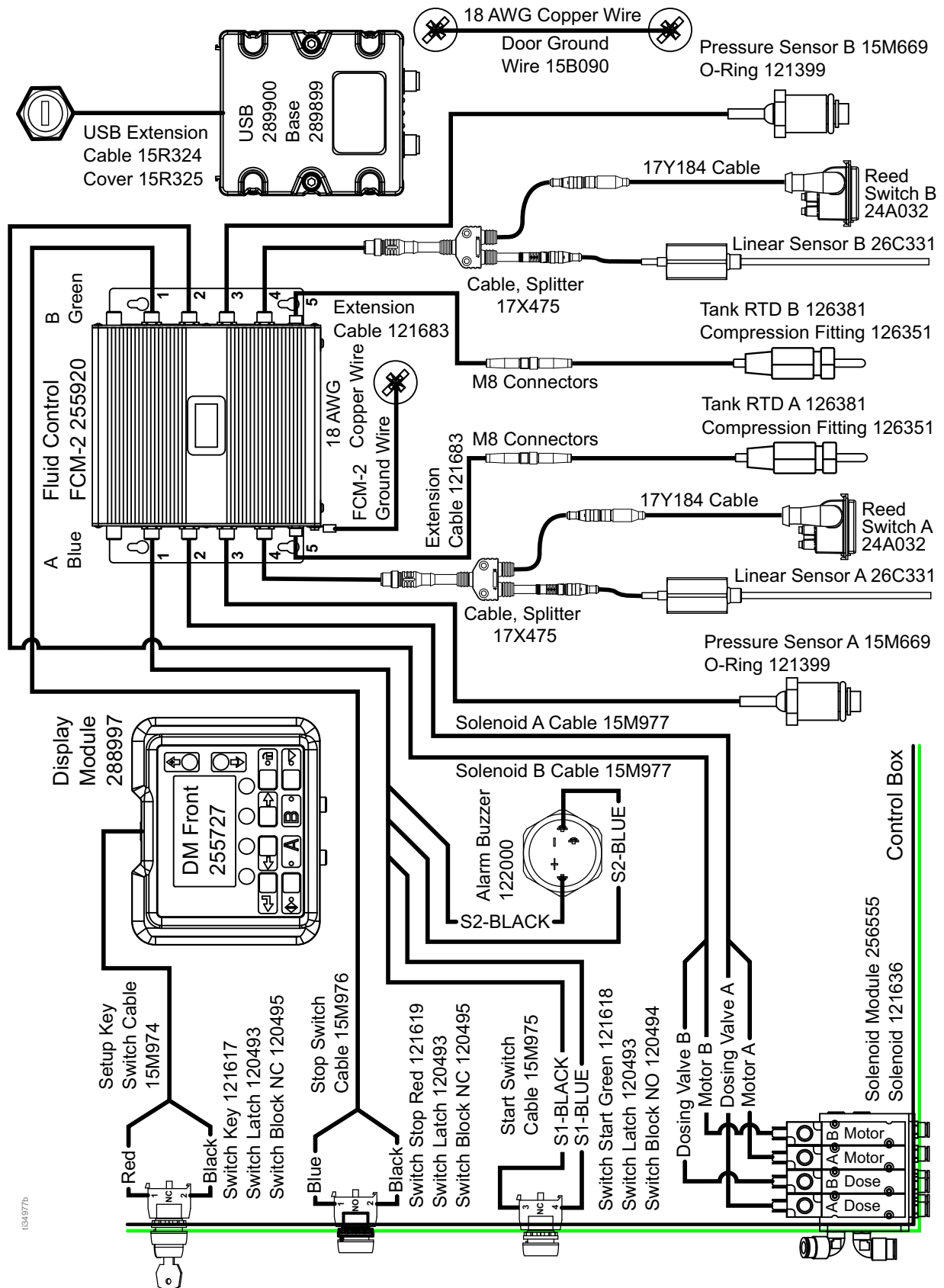

104977b

Non-Hazardous XM PFP Air Logic Schematic

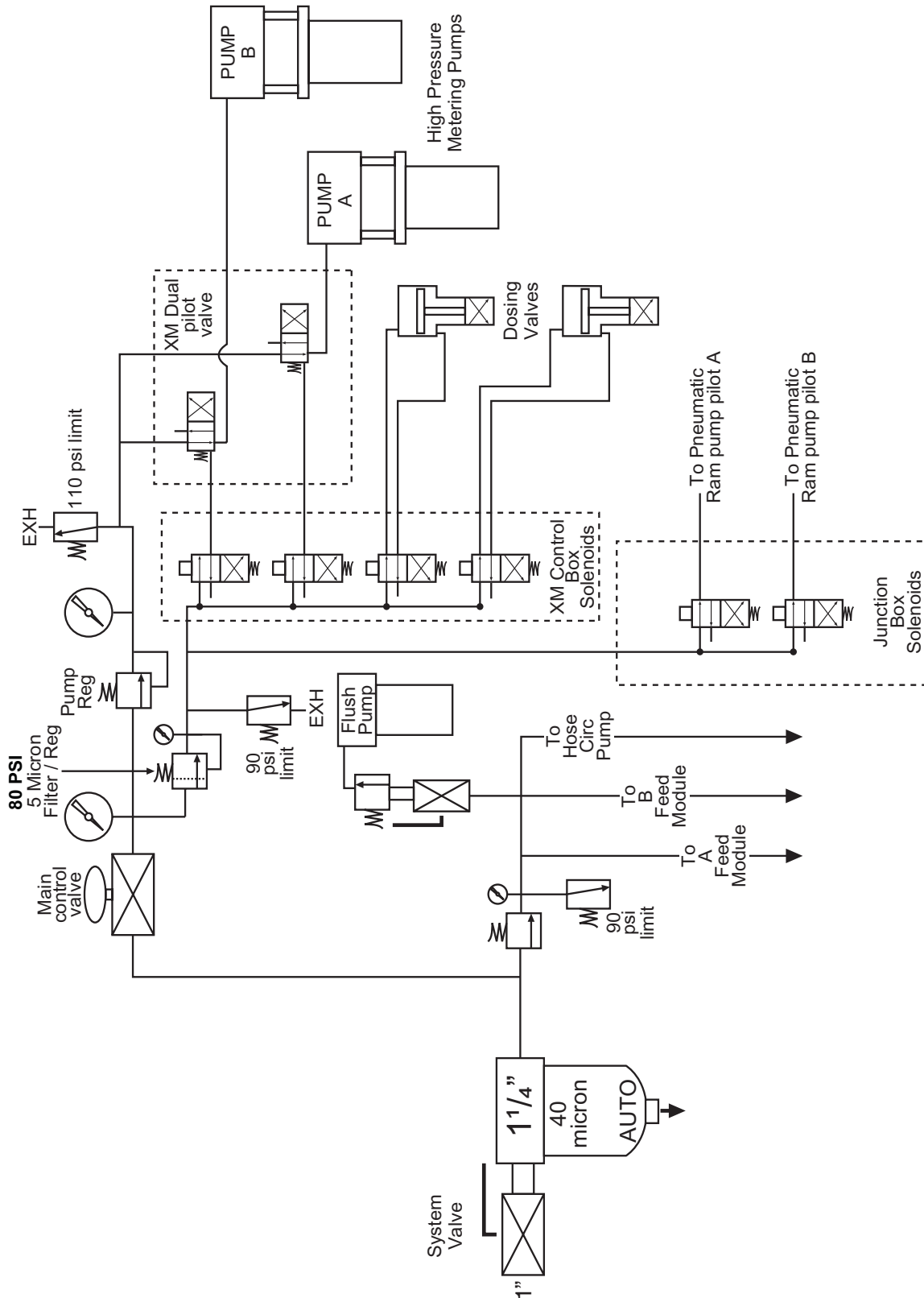

Feed Module Air Controls Schematic

Non-Hazardous Locations

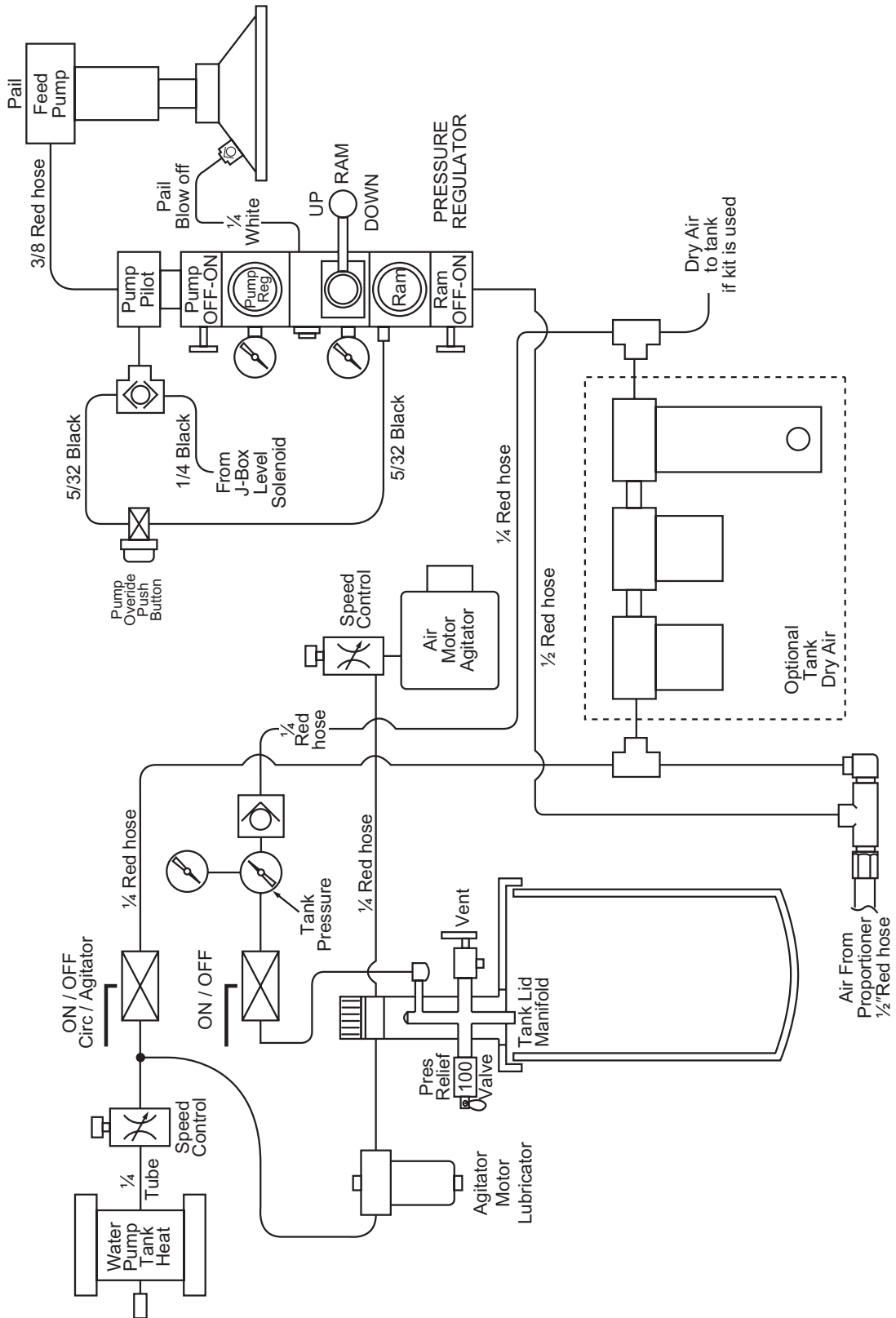

Hazardous Location Schematics

AC Power Schematic Explosion Proof Box

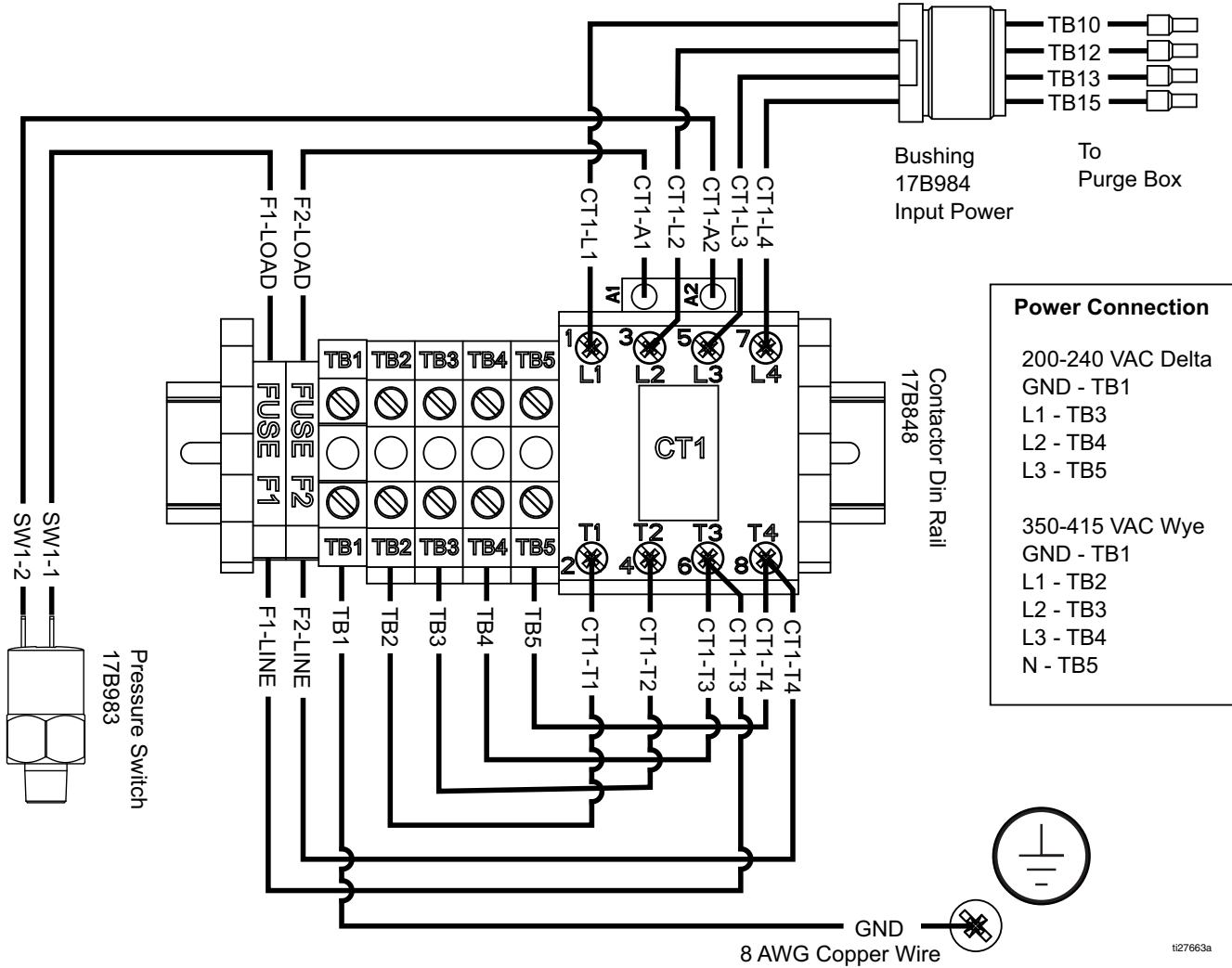

AC Power Schematic Purge Box

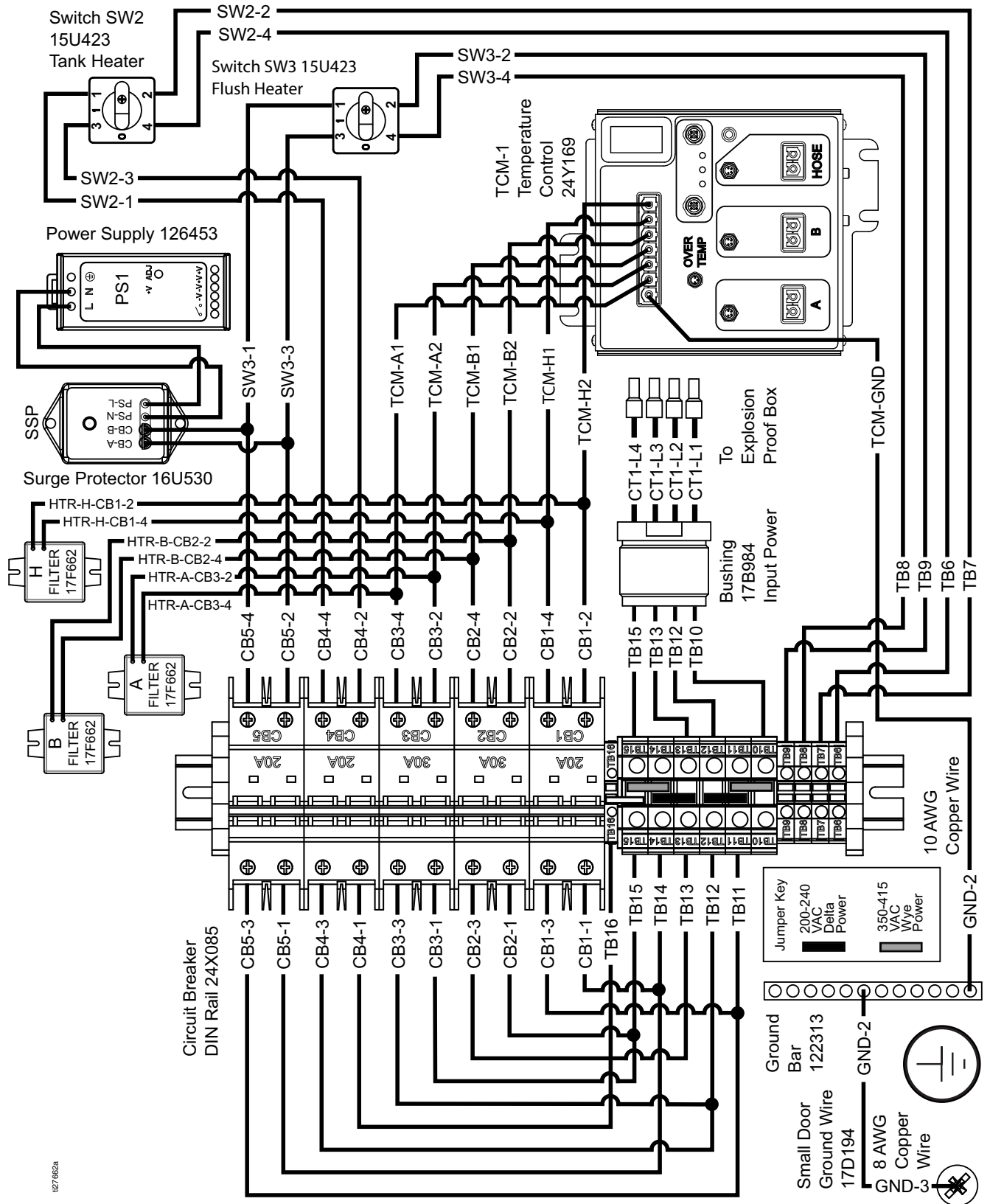

Heater Schematic Purge Box

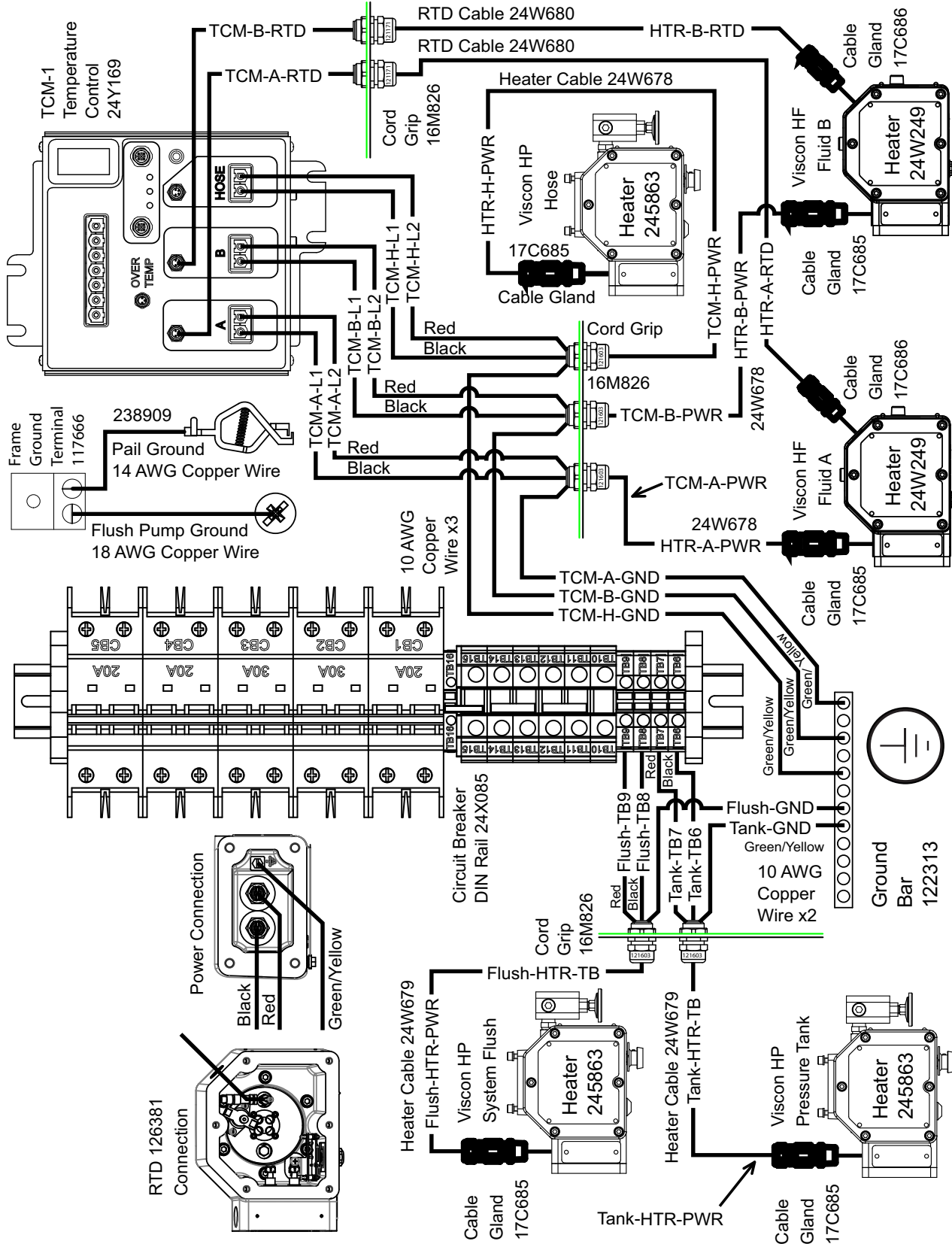

CAN Network and DC Power Schematic

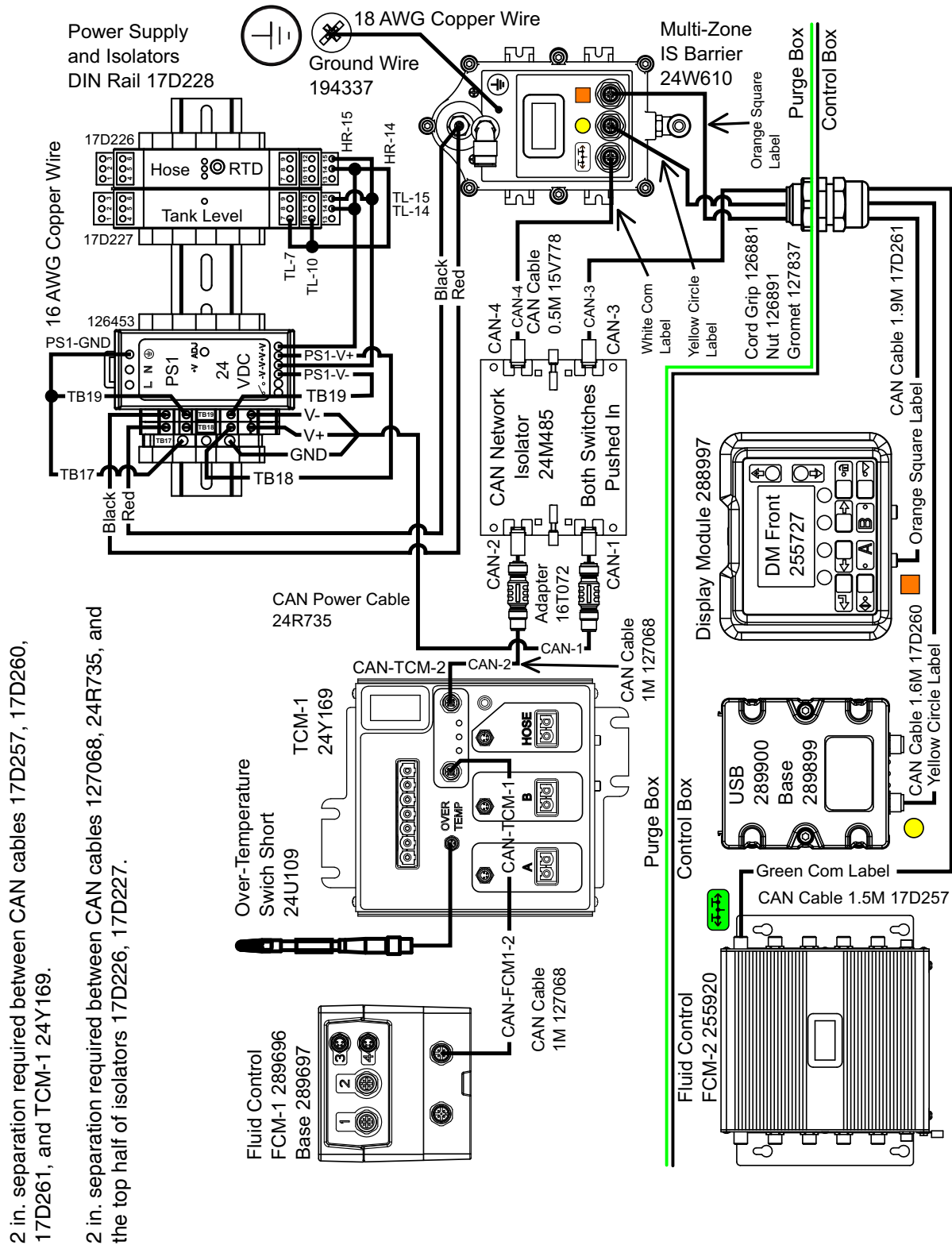

2 in. separation required between CAN cables 17D257, 17D260, 17D261, and TCM-1 24Y169.

2 in. separation required between CAN cables 127068, 24R735, and the top half of isolators 17D226, 17D227.

Sensors Schematic Purge Box

2 in. separation required between sensor cables 17D201, 17D202 and CAN network isolator 24M485 on previous page.

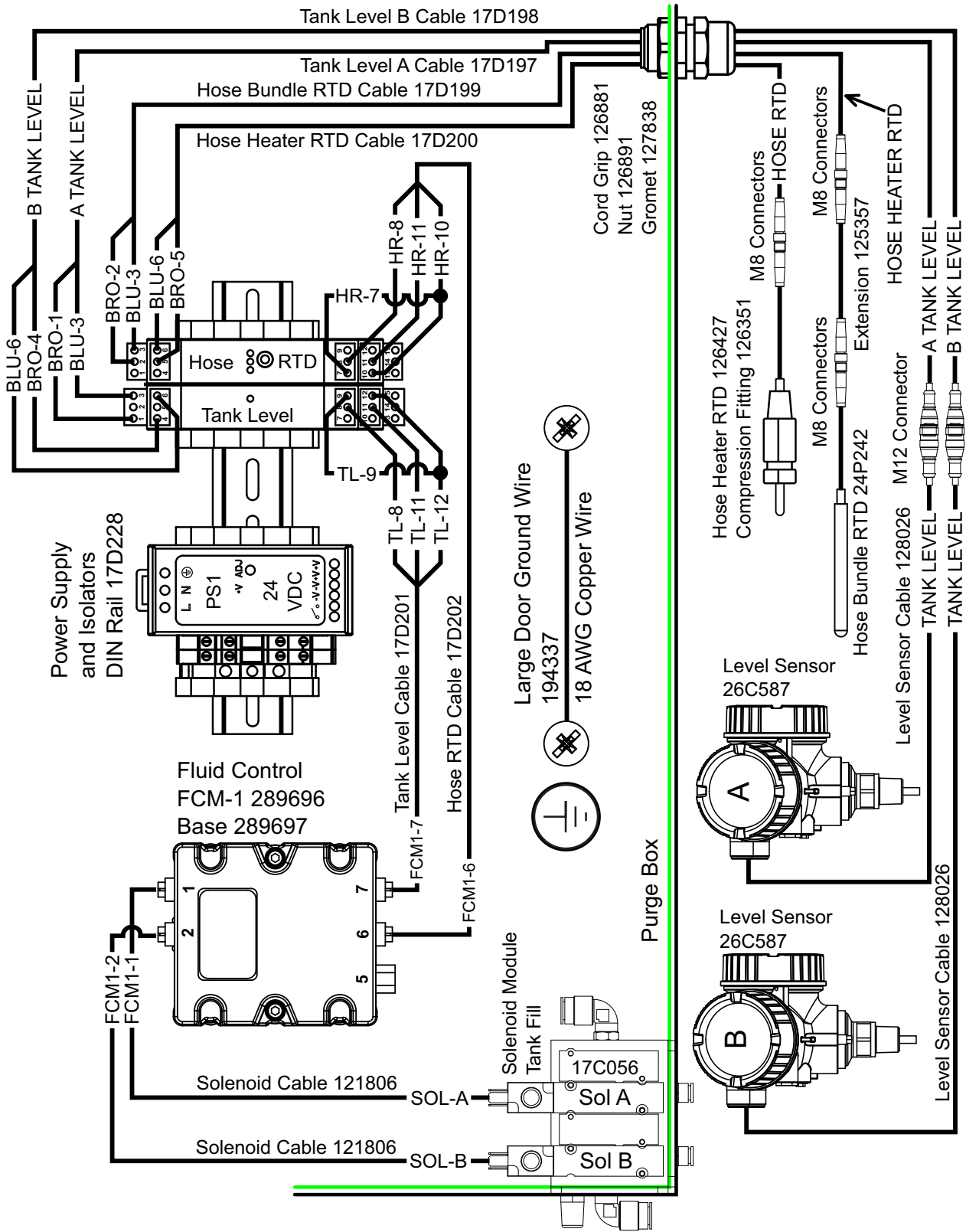

Sensors Schematic Control Box

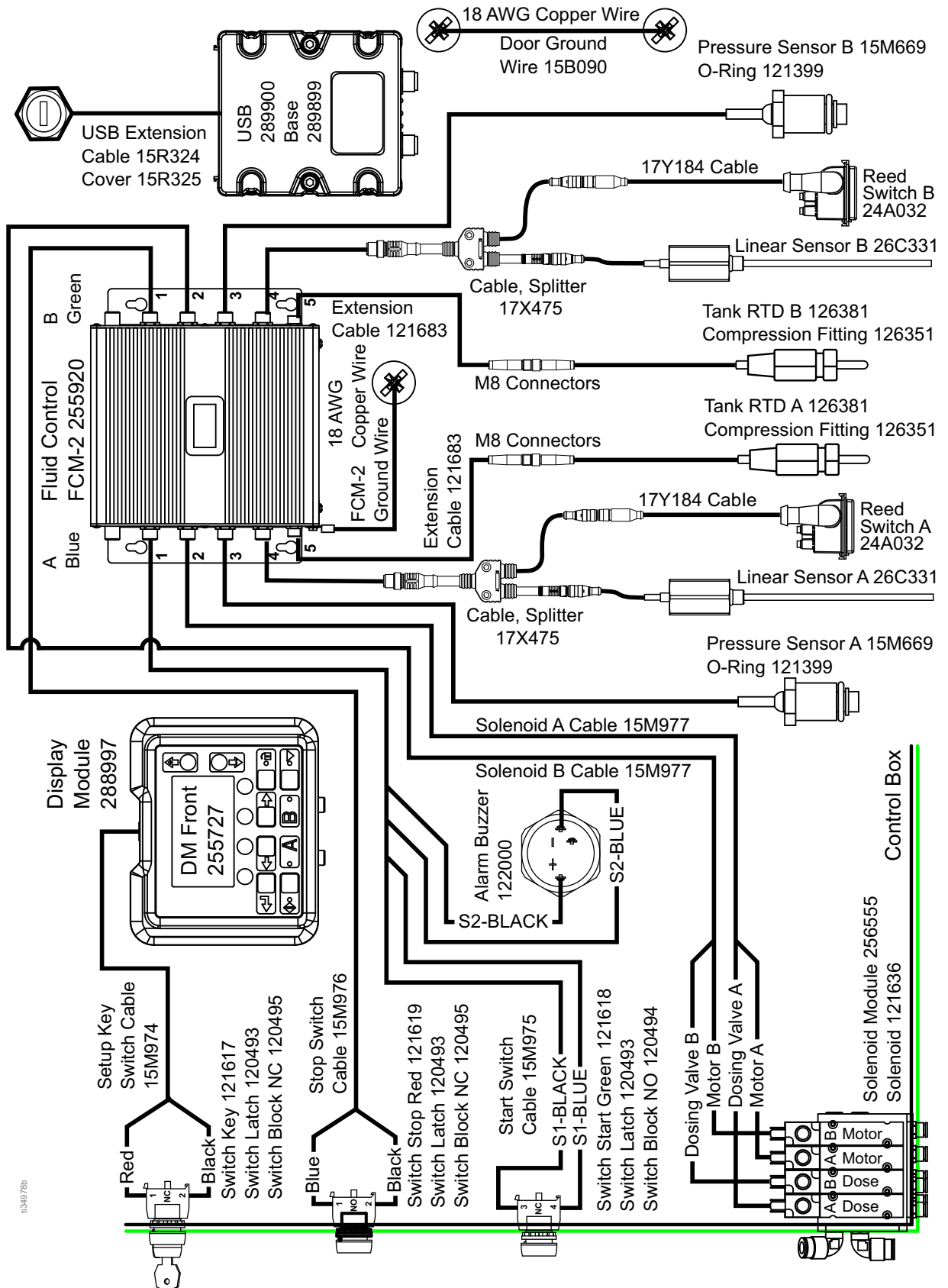

034978b

Hazardous XM PFP Air Logic Schematic

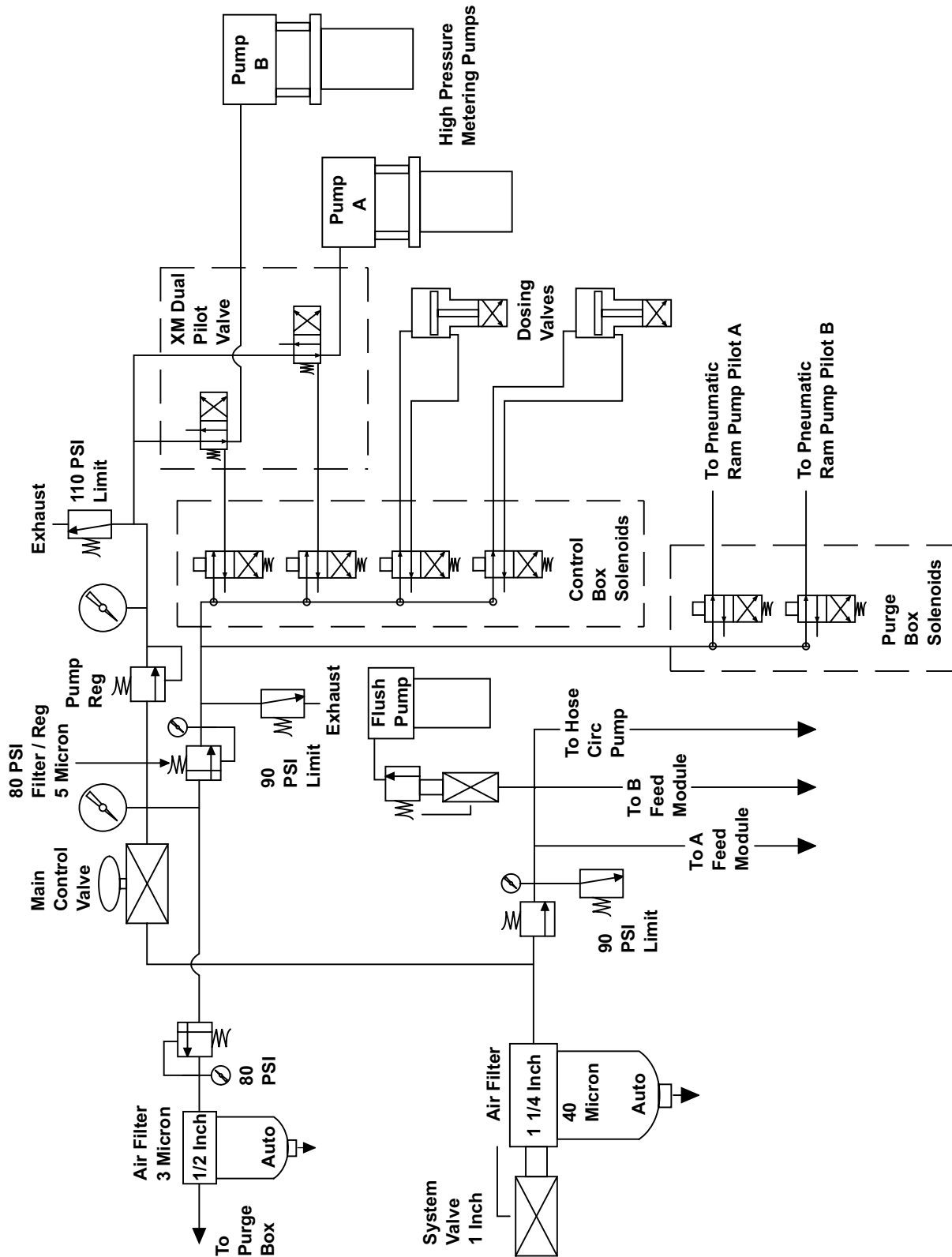

Feed Module Air Controls Schematic

Hazardous Locations

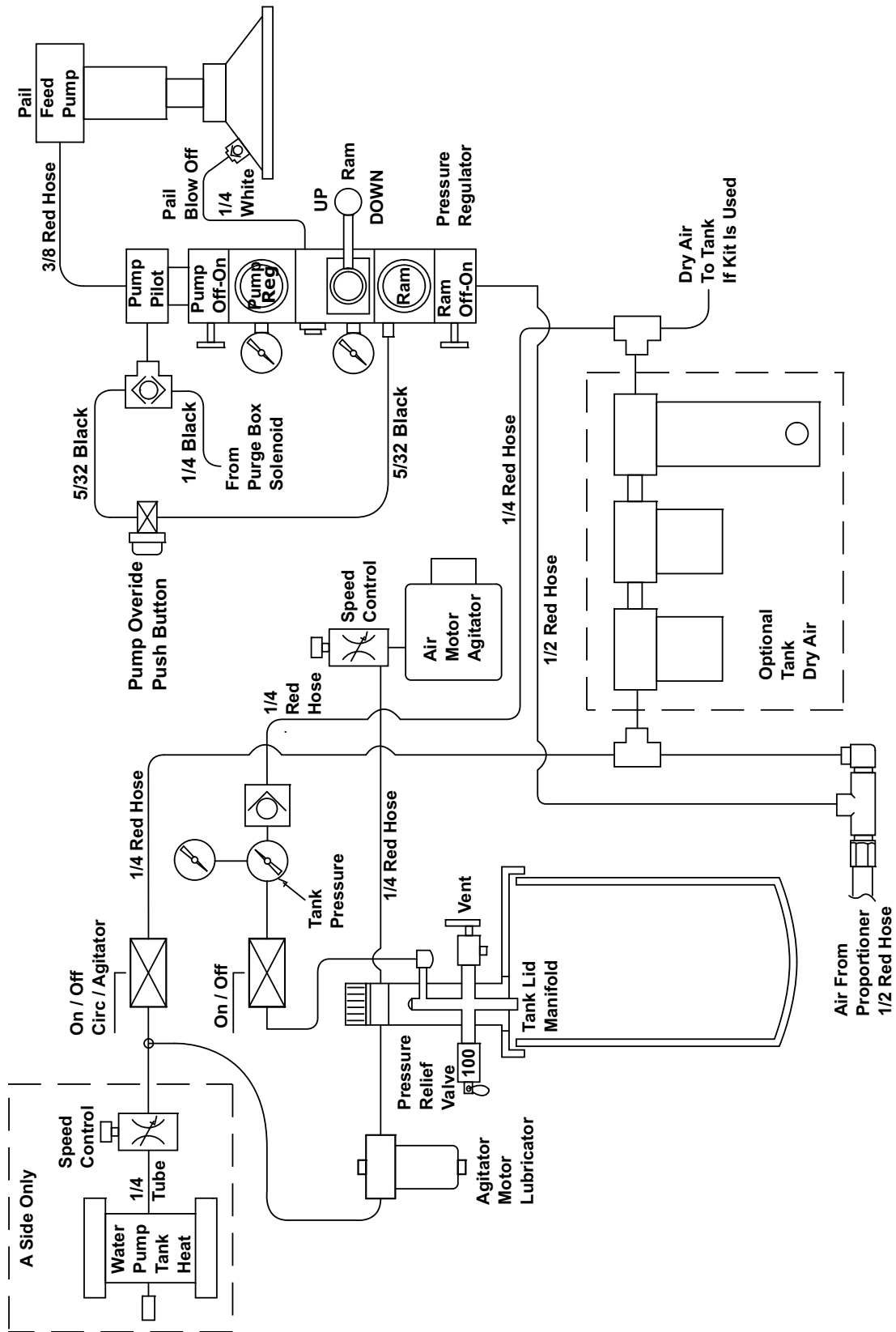

Hazardous Location Purge Box Air Controls Schematic

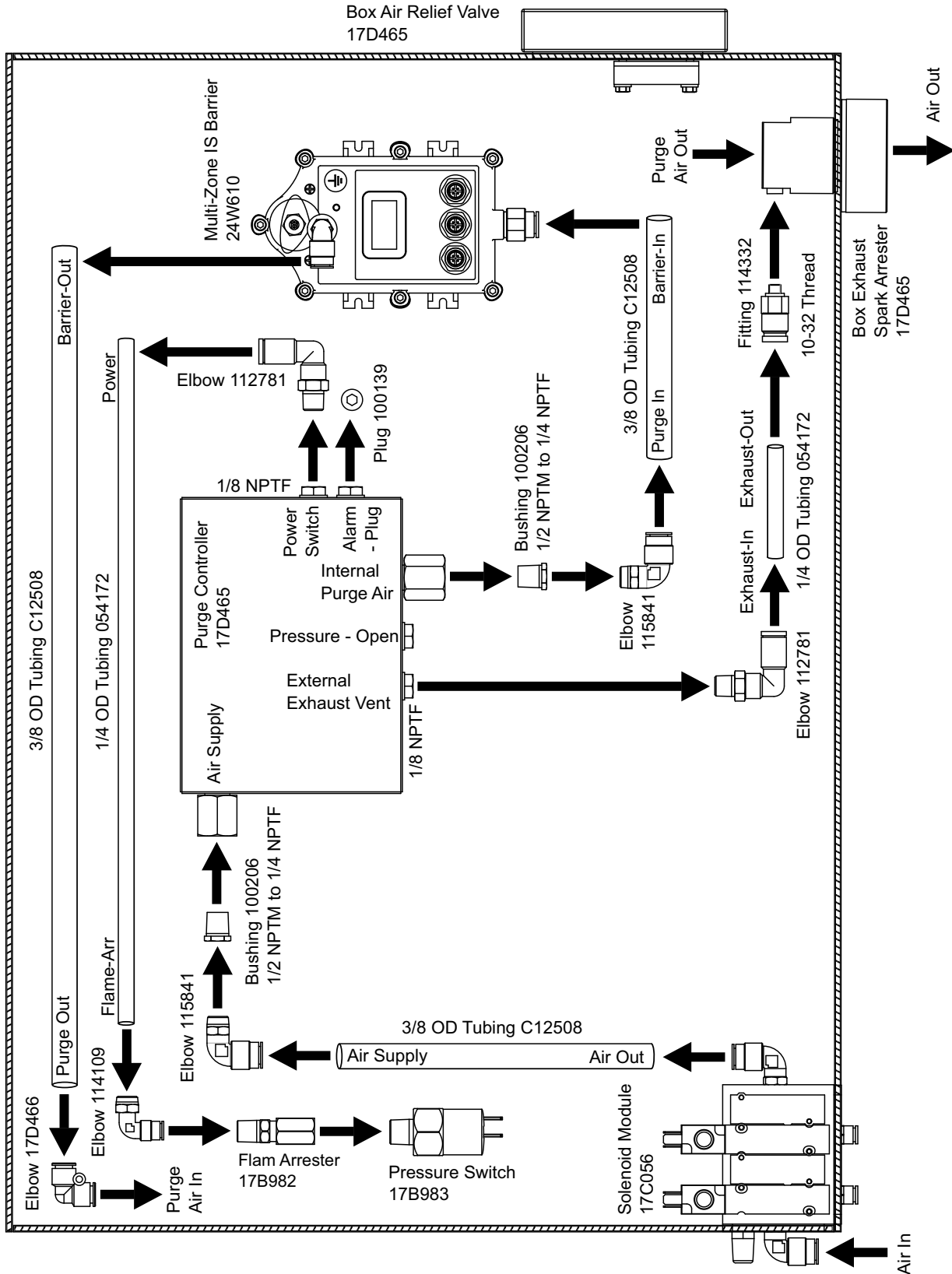

Parts

System	Location	Ratio Range	Item and Quantity				
			(1) Base System	(2) Feed Skid	(2a) Feed Module	(3) Hose Bundle	Included Accessories
262869	Non-Hazardous	1.5:1 to 4:1	262878	24P202	24Y097 (A)	16T121	
24W626		1:1 to 1.5:1			24Y098 (B)		
262943	Hazardous	1.5:1 to 4:1	262941	24W987	--- (NFS)	16T121	24X113 Ex Hot Water Flush
262945		1:1 to 1.5:1			24Y098 (B)		

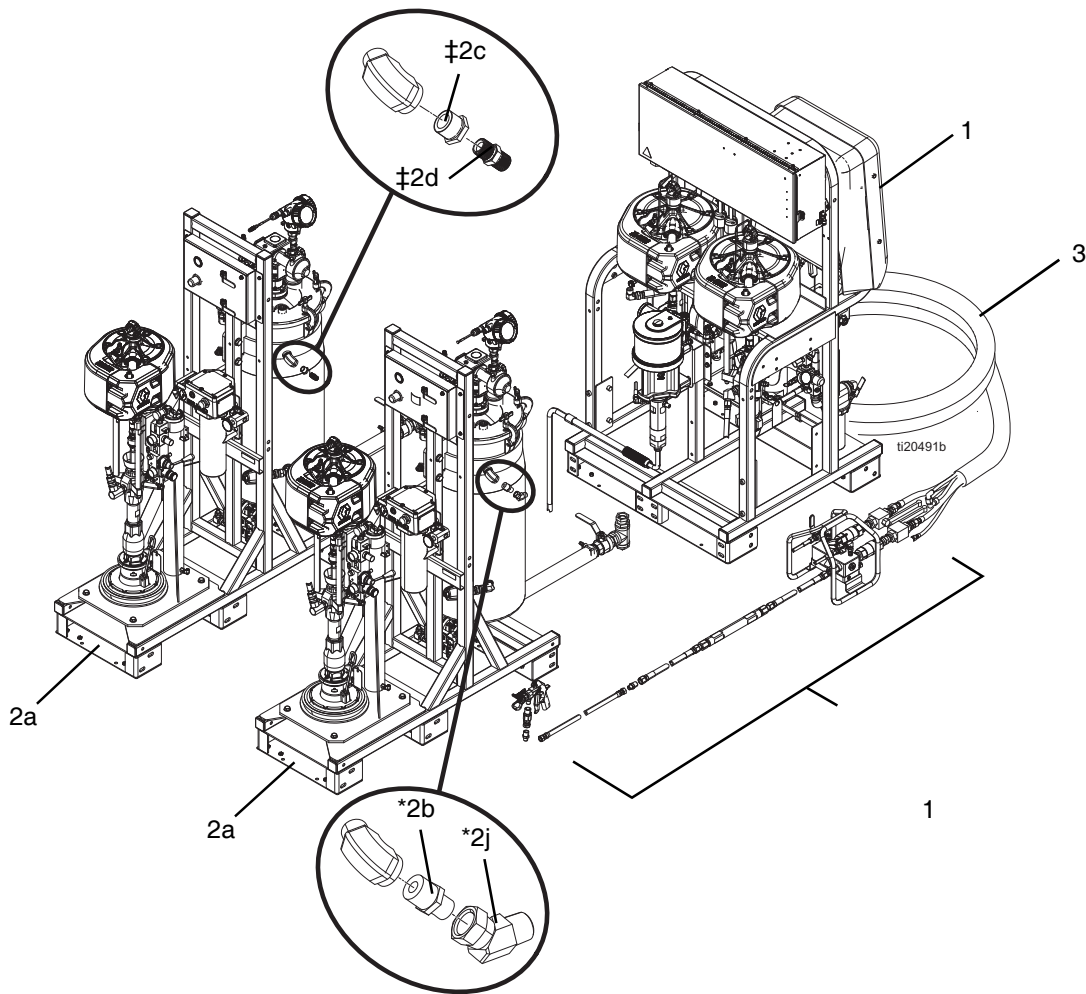

Ref.	Part	Description	Qty.
2b*	C20461	NIPPLE, reducing	1
2c‡	100505	BUSHING	1
2d‡	156849	NIPPLE	1
2f◆	15U654	LABEL, A/B Identification	1
2g◆	061134	HOSE, nylon	2.5
2h◆	---	CABLE TIE	8
2j	222297	UNION, adapter	1

--- Not for sale.

◆ Not shown.

✕ Not included.

All machines are set up for 1/2" ID A and 3/8" ID B circulation return hoses. All machines come with a kit to convert to 1/2" A and 1/2" B return hoses for materials with very high viscosity B material.

XM PFP System Subassemblies

Non-Hazardous Location Base System (262878)

Hazardous Location Base System (262941)

Page 1 of 5

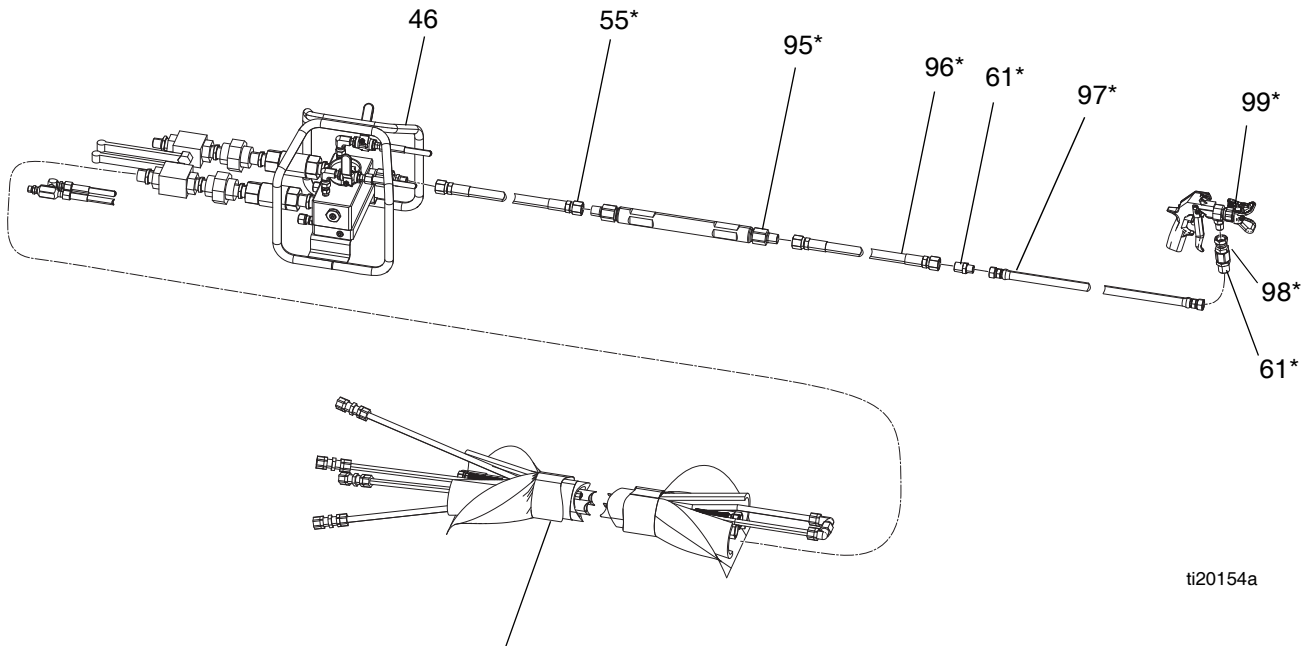

Heated Hose Bundle 16T121 (3/4 x 1/2) included with assemblies 262869 and 262943.

Heated Hose Bundle 16T122 (3/4 x 3/4) included with assembly 262945 and 24W626.

NOTE: Apply pipe sealant to all non-swiveling pipe threads.

* *Mix Replacement Kit 24P833*

Base System (262878, 262941) page 2 of 5

Set air regulator to 80 psi
(550 kPa, 5.5 bar)

262941 hazardous unit only

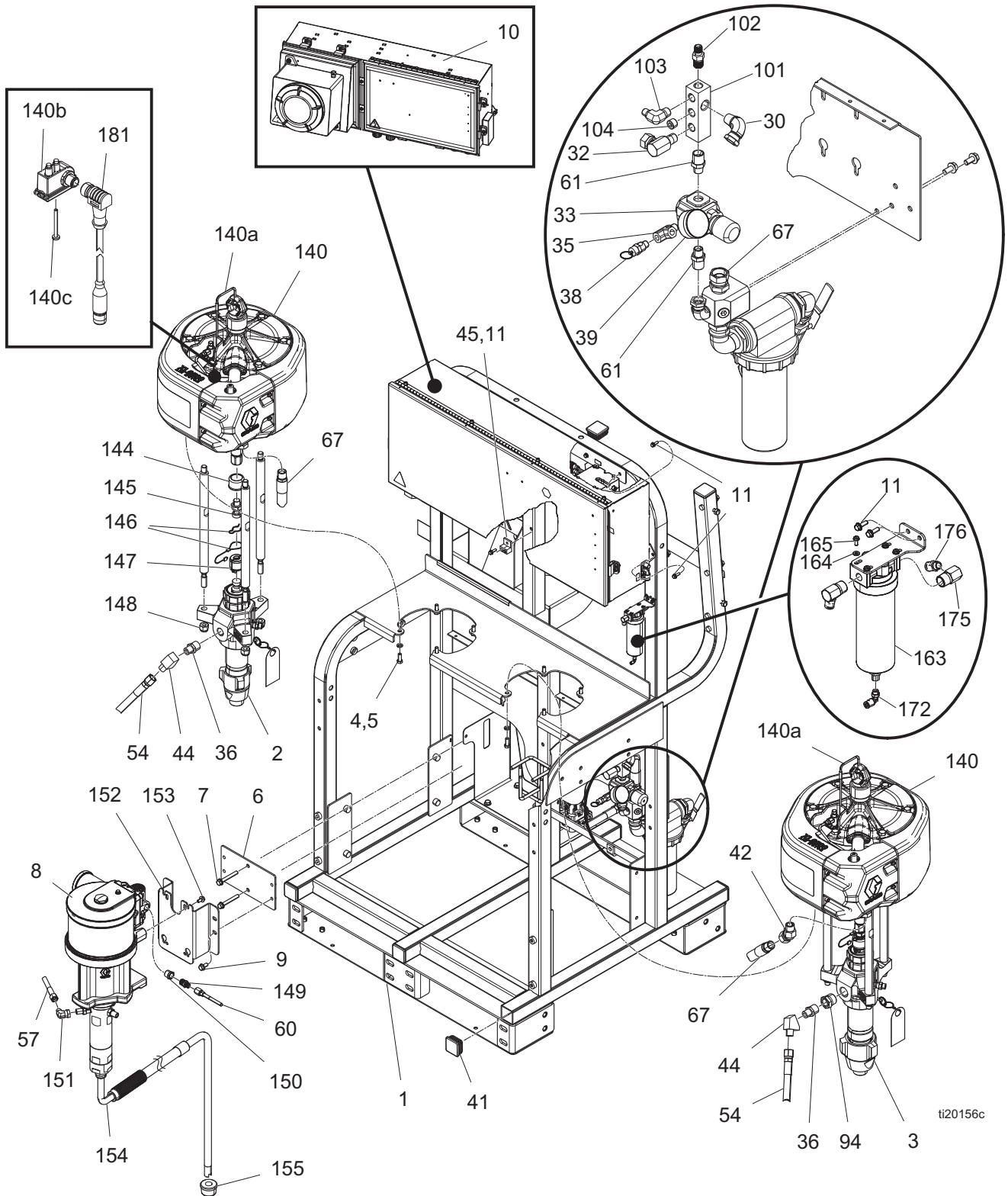

ti20156c

262941 only

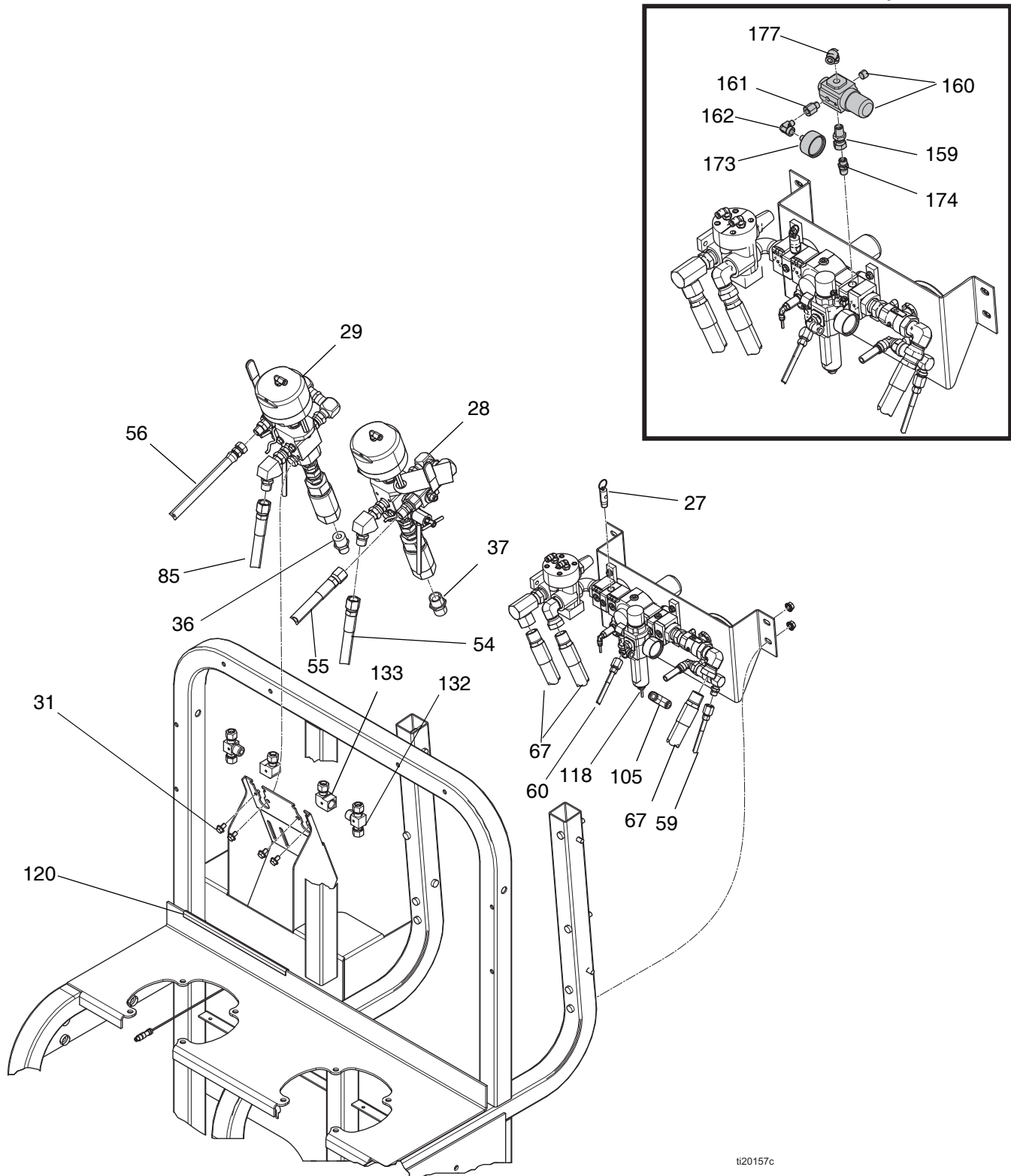

ti20157c

Base System (262878, 262941) page 4 of 5

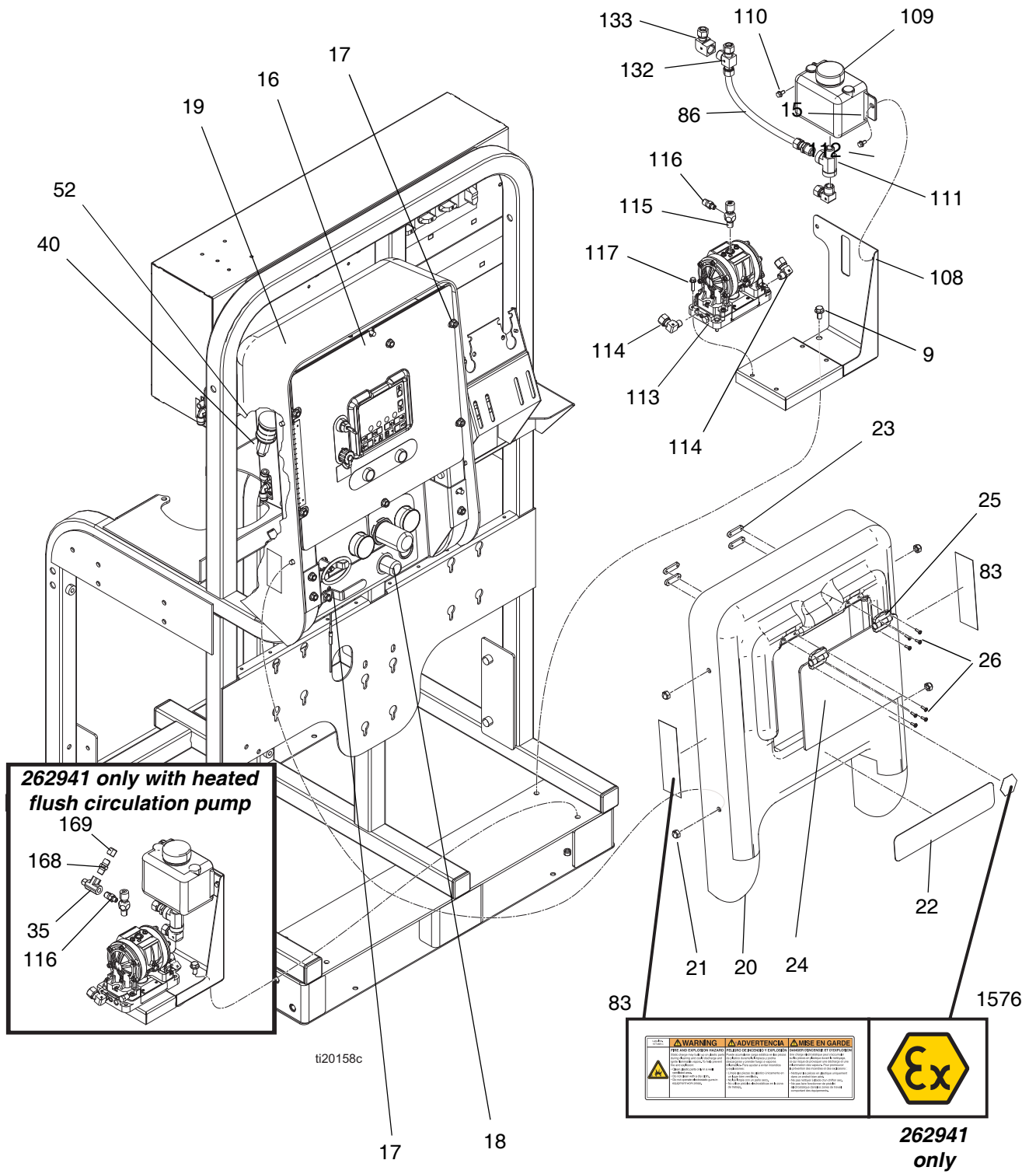

Base System (262878, 262941) page 5 of 5

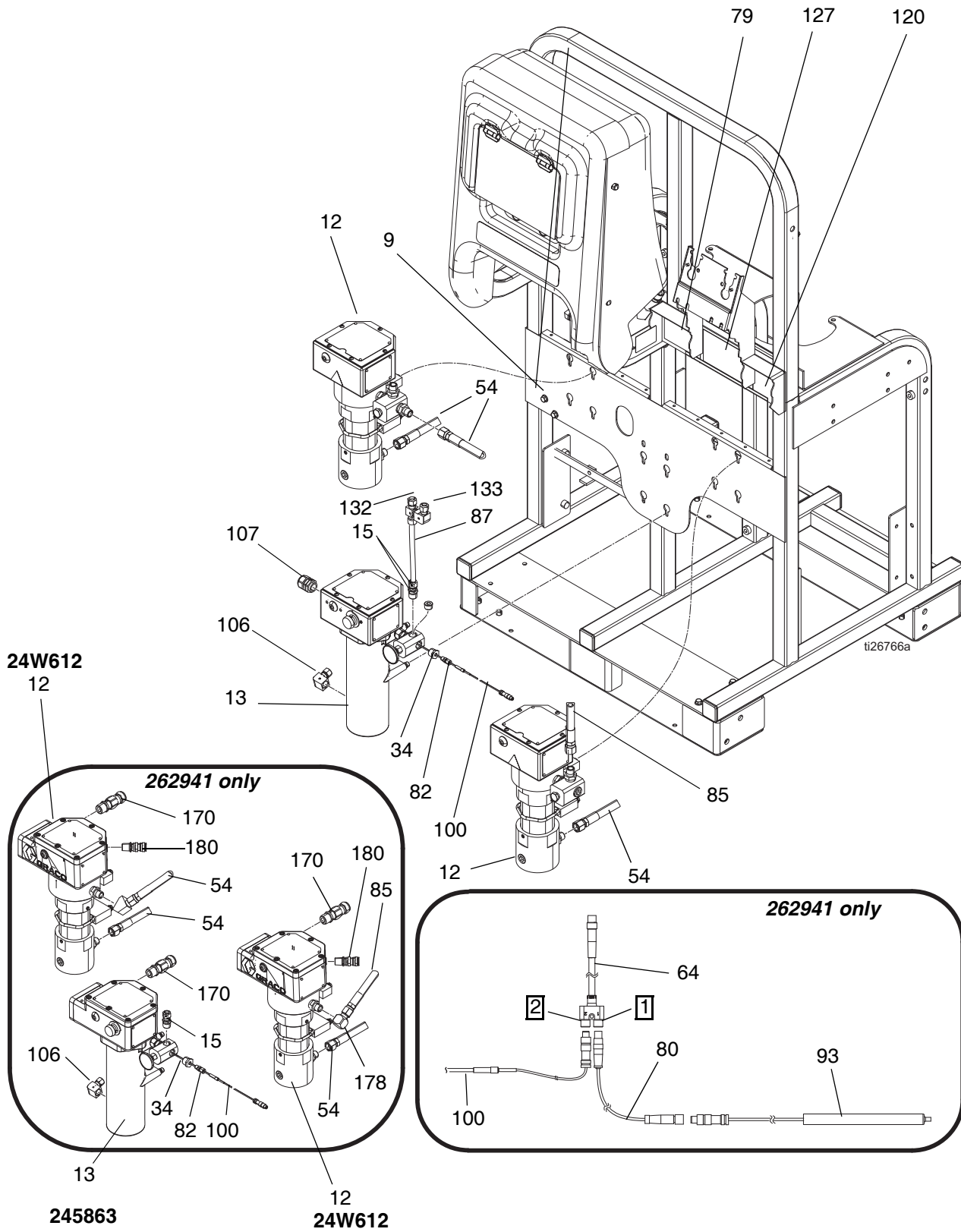

Base System (262878, 262941)

Ref.	Part	Description	Qty.	Ref.	Part	Description	Qty.
				37	160032	FITTING, nipple Model 262878	2
1	---	FRAME	1	38	116643	VALVE, safety, relief, air	1
2	L180C9	PUMP; B side lower	1	39	101689	GAUGE, press, air	1
3	L220C9	PUMP; A side lower	1	40	121688	CONNECTOR, 3/8 npti x 3/8 tube	1
4	100133	WASHER, lock, 3/8	8			ptc	
5	100101	SCREW, cap, hex head	8	41	115313	PLUG, tube	8
6	256169	PLATE, flush pump	1	42	105281	3/4 npt, 45 degree	1
7	121488	SCREW, hex head, flanged	2	44	15M987	FITTING, elbow, 60 degree	2
8	W30CAS	PUMP, solvent, 6.0 in, 75 cc; see 312794	1	45	117666	TERMINAL, ground	1
9	112395	SCREW, cap, flange head	8	46	262893	MANIFOLD, mix; see manual 3A2988	1
10	24Y247	JUNCTION BOX; see page 71	1	47	---	SEALANT, pipe, stainless steel	1
	24W074	PURGE BOX, explosion proof; 262941 only, see page page 64	1	48	---	LUBRICANT, thread	1
11	113796	SCREW, flanged, hex head Model 262878	6	49	---	SEALANT, anaerobic	1
		Model 262941	10	50	206995	FLUID, TSL, 1 qt.	1
12	262853	HEATER, Viscon HF	2	52	108636	MUFFLER	1
	24W612	HEATER, Viscon HF; 262941 only	2	53▲	15X393	LABEL, warning, USB, all languages	1
13	245869	HEATER, Viscon HP	1	54	H75003	HOSE, coupled, 7250 psi, 0.50 in. ID, 3 ft	3
	245863	HEATER, Viscon HP; 262941 only	1	55	H75004	HOSE, coupled, 7250 psi, 0.50 in. ID, 4 ft	3
14	24P899	FILTER, air, 1-1/4, assembly, page 75	1			Model 262878	3
15	126899	FITTING, compression, straight	2			Model 262941	3
16	255771	BOX, control, air/electric, see Control Box (16) , page 73	1	56	H73806	HOSE, coupled, 7250 psi, 0.375 in. ID, 6 ft	1
17	112958	NUT, hex, flanged	10			(Model 262878 only)	
18	255761	MODULE, air controls, upper	1	57	H42506	HOSE, coupled, 4500 psi, 0.25 in. ID, 6 ft	1
19	---	COVER, shroud, rear	1	58	205418	HOSE, coupled, air, 1/2 x 6 ft	2
20	256177	COVER, shroud, front	1	59	16P244	HOSE, coupled, air, 5/16 x 3 ft	2
21	117623	NUT, cap, 3/8-16	4	60	248208	HOSE, coupled, air, 5/16 x 4 ft	1
22	---	LABEL, XM PFP	1	61◆	159239	FITTING, nipple, pipe, reducing	4
23	15T567	NUT, backup plate, hinge	4	62	17L724	FLASH DRIVE, USB, 2.0	1
24	15T568	DOOR, control shroud	1	63	121456	CONNECTOR, power, male, 3 pin	1
25	121471	HINGE, friction, positioning	2	64	125806	CABLE, splitter, M8, 4-pin, female/female/male, 1.5 m	1
26	112380	SCREW, mach, pan head	8	65	126511	CABLE, GCA, M8, 4-pin, 1.5 m, male/female	2
27	113498	VALVE, safety, 110 psi	1	66	16T123	CABLE, GCA, CAN, male/female, 1.0 m	1
28	---	VALVE, ratio control, left; see page 76	1	67	240900	HOSE, coupled, air, 30 in. x 3/4 in.	3
29	---	VALVE, ratio control, right; see page 76	1	68	054172	TUBE, nylon, round, black, 1/4 in.	26.5
30	C19024	FITTING, elbow, swivel	1	69	054175	TUBE, nylon, round, natural, 1/4 in.	8.5
31	111801	SCREW, cap, hex head	8	70	551390	SIGHTGLASS, beaker, graduated	10
32	217430	FITTING, swivel, union, 90 degree	1	71	---	STRAP, tie	20
33	15T536	REGULATOR, air, 3/8 npt	1	73	238909	WIRE, grounding assembly	1
34	100329	BUSHING, pipe	1	74	C12508	TUBING, nylon, round, black, 3/8 in.	4.7
35	116504	FITTING, tee, run Model 262878	1				
		Model 262941	2				
36	C20461	FITTING, nipple, reducing, hex Model 262878	3				

Parts

Ref.	Part	Description	Qty.	Ref.	Part	Description	Qty.
76	109025	TERMINAL, ring	1	118	054760	TUBE, polyurethane, round, black	5
79	16P856	LABEL, codes, alerts; all languages	1	119	100028	WASHER, lock	1
80	125357	CABLE, M8, 4-pin, male/female, 1 meter	1	120	115901	TRIM, edge, protection	2
81	126494	CABLE, M12, 5p, 4-wire with drain	2	121	16T171	STRAP, frame connector	2
82	126351	FITTING, compression, thermocouple	1	122	100679	SCREW, cap, hex head	8
83▲	15T468	LABEL, warning	2	123	115211	SCREW, cap, hex head	2
85◆	H75002	HOSE, coupled, 7250 psi, 0.5 in. (12 mm) ID, 2 ft	1	124	---	SCREW, hex head with serrated face flange base, 1/2-13	8
86	---	TUBE, 0.375 in. (9.5 mm) ID blue nylon	6	125	109570	WASHER, plain	20
87	---	TUBE, 0.375 in. (12 mm) ID red nylon	1.5	126	112731	NUT, hex, flanged	10
88	114601	CONDUIT, flexible, non-metallic	3.5	127▲	15W598	LABEL, warning	1
92	15T258	TOOL, wrench, Xtreme, 145/290	1	128	15U654	LABEL, identification, A/B	1
93	24P242	SENSOR, RTD, 1k ohm, insulated	1	129	---	FLUID, ethylene glycol/water	2
94	158586	FITTING, bushing	1	131	16F366	FITTING, 1/4 in. x 1/4 in. push to connect	2
95◆	16T316	MIXER, static, assembly, page 80	1	132	126346	FITTING, tee, tube x tube x nptm	2
96◆	H75010	HOSE, coupled, 7250 psi, 0.50 ID, 10 ft	1	133	126345	FITTING, elbow, tube x nptf	2
97◆	H73803	HOSE, coupled, 7250 psi, 0.375 ID, 3 ft	1	135	121683	CABLE, M8, 4-pin, male/female, 3 meter	2
98◆	24P834	SWIVEL, straight	1	136	122032	NUT, wire	2
99◆	262854	GUN, spray	1	137	15V778	CABLE, CAN, female-female, 20 in.	1
100	126427	SENSOR, RTD, 1K ohm, 4 pin, 8 in.	1	138	15V779	CABLE, CAN, female-female, 34 in.	1
101	158990	MANIFOLD, air	1	140	XL65D2	MOTOR, 6500 with sensor	2
102	165198	FITTING, nipple, reducing	1	140a	26C331	LINEAR SENSOR ASSEMBLY	
103	121858	FITTING, elbow, 3/8 npte x 1/4 npte	1	140b	24A032	REED, switch	
104	101754	PLUG, pipe	1	141	100133	WASHER, lock	8
105	119798	CONNECTOR, tee, push-tube	1	142	100101	SCREW	8
106	126896	FITTING, elbow, tube	1	143	257150	ROD, tie	6
107	121603	GRIP, cord, 0.51-0.71, 3/4	1	144	197340	COVER, coupler	2
108	16T745	BRACKET, water circulation, mount	1	145	15H392	ROD, adapter	2
109	16R871	BOTTLE, overflow, 1/2npt	1	146	244820	CLIP, hairpin lanyard	2
110	113161	SCREW, flange, hex head	2	147	244819	COUPLING, assembly rod	2
111	108126	FITTING, tee, street	1	148	101712	NUT, nyloc	6
112	126898	FITTING, elbow	1	149	157350	ADAPTER, 3/8 x 1/4	1
113†	24P835	PUMP, diaphragm, 205	1	150	100081	BUSHING	1
114	126897	FITTING, elbow	2	151	116395	UNION, 90 degree, 1/4 male x 3/8 swivel	1
115	206264	VALVE, needle	1	152	256561	PLATE, mount, pump	1
116	151519	FITTING, nipple, reducing; Model 262878 and 24W648	1	153	111799	SCREW, M8 x 1.25 x 16 mm	4
	16D939	FITTING, nipple, reducing; Model 262941	1	154	256421	HOSE, siphon	1
117	15R472	FASTENER, hex head, flanged, 1/4 x 1	4	155	181073	STRAINER, inlet	1
				156	24X461	KIT, circulation, 1:1 fitting	1
				157†	190451	UNION, adapter	1
				158†	162505	FITTING, union, swivel	1
				159†	156823	FITTING, union, swivel	1
				160†	116513	REGULATOR, air	1
				161†	16T421	ADAPTER, pipe hex	1
				162†	112307	FITTING, street elbow	1
				163†	234402	KIT, filter, air	1

Ref.	Part	Description	Qty.
164 †	102360	WASHER, flat	4
165 †	---	SCREW, mach, slot hex washer hd, 10-24 x 1/2 in.	4
166 †	24P834	SWIVEL, straight, PTFE	1
167 †	---	NIPPLE, 3/8 - 1/4 npt x 2.6 in.	1
168 †	156971	FITTING, nipple short	1
169 †	---	FITTING, cap, hex, 1/4 npt(f)	1
170 †	24W678	CABLE, assembly, armored	3
171 †	---	BRACKET, air filter	1
172 †	112698	ELBOW, male, swivel	1
173 †	113911	GAUGE, pressure, air	1
174 †	162453	FITTING, 1/4 npsm x 1/4 npt	1
175 †	166999	FITTING, elbow, street, 1/2M x 1/4F	2
176 †	122161	FITTING, air	2
177 †	115841	FITTING, elbow	1
178 †	158683	FITTING, elbow, 90°	1
179 †	17D946	LABEL, cord wrap	1
180 †	24W680	CABLE, assembly, armored	2
181	17Y184	CABLE, GCA, M12-5P	2

--- Not for sale.

▲ Replacement Danger and Warning labels, tags and cards are available at no cost.

† 262941 only.

◆ Included in mix line and gun kit 24P833.

24X461 1:1 Fitting Kit

Use to convert the B side recirculation parts on 262941 for 1:1 ratio materials. See manual 334939 for detailed instructions.

Feed Modules

Page 1 of 2

B Side Feed Module, 24Y098

A Side Feed Module, hazardous area unit, see items 226 and 325

A Side Feed Module, 24Y097

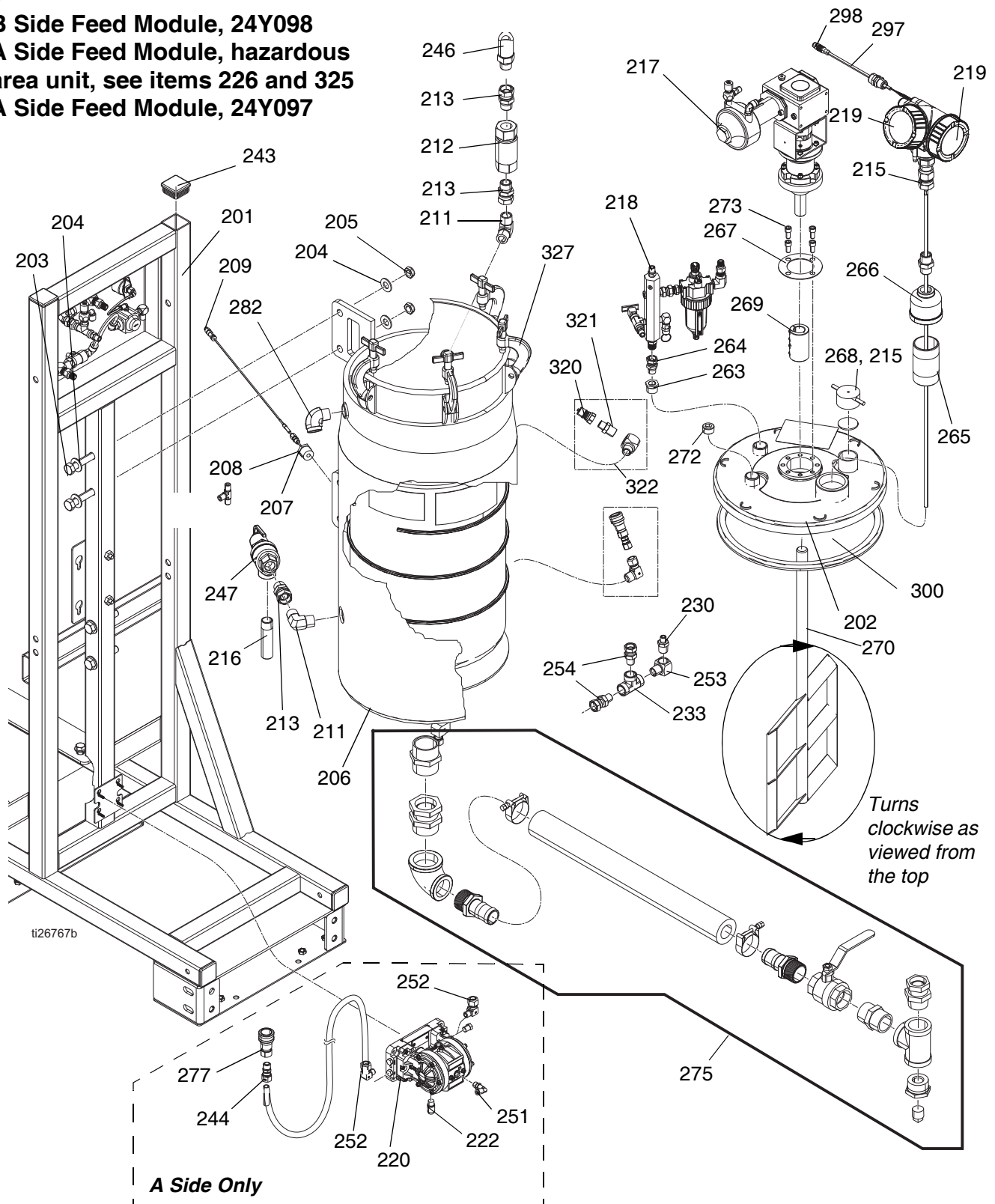

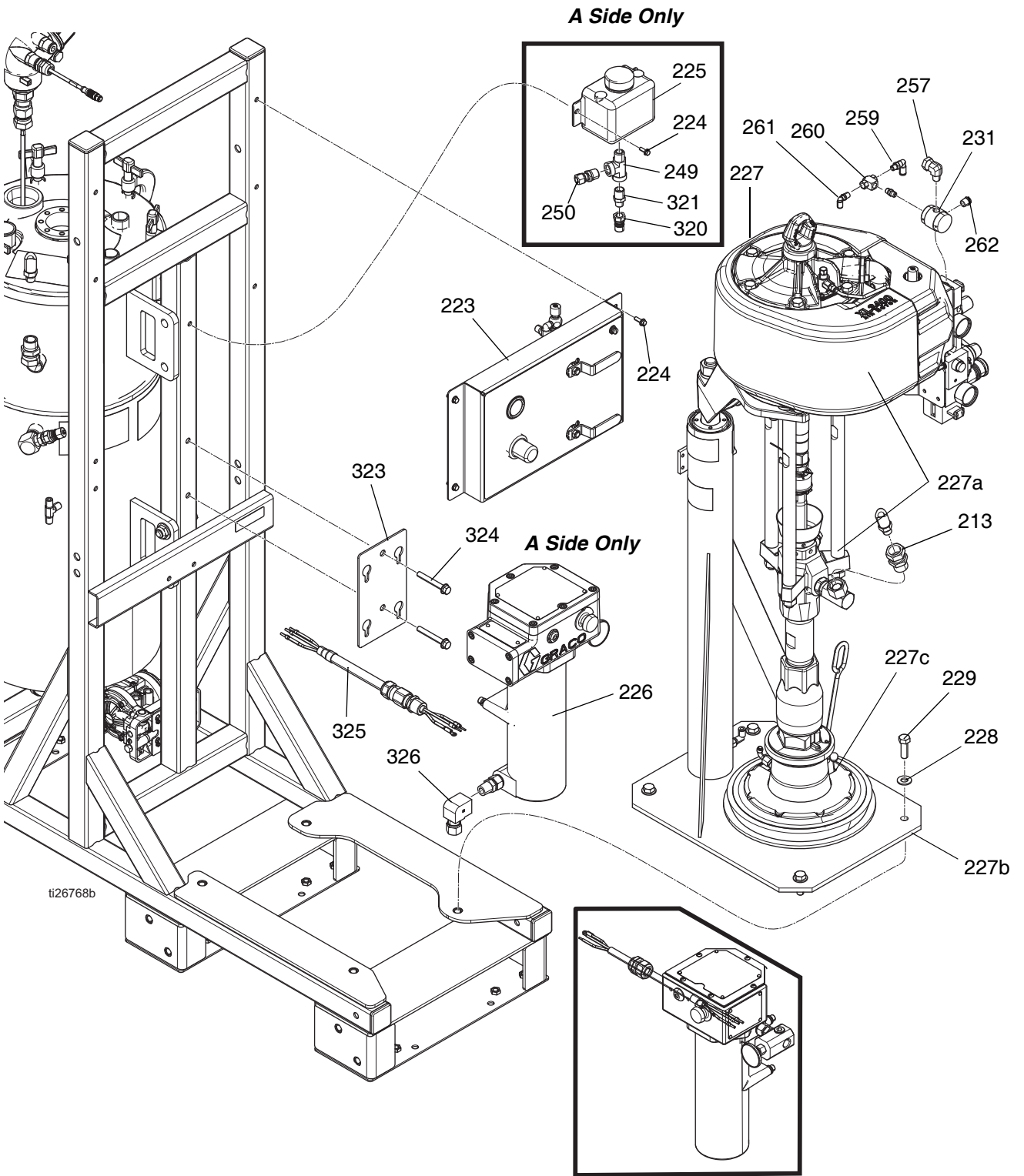

Feed Modules Continued

Ref.	Part	Description	Qty.	Ref.	Part	Description	Qty.
201	---	FRAME	1	227b	257620	S20 RAM, see 313527	1
202	24M683	TANK, pressure, assembly	1	227c	16U676	PLATEN, pail, see 3A3113	1
203	---	BOLT, hex head, 3.25 in. long, 5/8-11	4	228	GC2041	WASHER, flat, std, 1/2	4
204	111841	WASHER, plain 5/8	8	229	100017	SCREW, cap, hex head	4
205	---	NUT, self-locking hex, nylon insert, 5/8-11	4	230	117426	INSERT, tube	6
206	16R869	COVER, tank wrap	1	231	104633	VALVE, pilot	1
207	---	BUSHING, pipe, hex head, 3/4 npt x 1/8 npt, steel	1	232	---	SEALANT, pipe, stainless steel	1
208	126351	FITTING, compression, thermocouple	1	233	103475	FITTING, tee, pipe	1
209	126381	SENSOR, RTD, 1k ohm, 4 pin, 3 in.	1	234	---	TUBE, 0.375 in. (9.5mm) ID red nylon	3.8
210	126898	FITTING, elbow	2	235	---	TUBE, 0.375 in. (9.5mm) ID blue nylon	4.2
211	295847	FITTING, elbow, 90, 3/4 mpt	2	236	205418	HOSE, coupled	1
212	16T481	VALVE, check (see page 82)	1	237	109130	HOSE, coupled, 48 in.	1
213	157785	FITTING, swivel	4	238	16P244	HOSE, coupled, 3 feet	3
215	171988	GASKET, inspection cap	1	239	15B772	HOSE, air, 18 inch	3
216	16T619	FITTING, nipple, thread on one end	1	240	054172	TUBE, nylon, round	12
217	24P885	AGITATOR, assembly, air (see page 77)	1	241	054753	TUBE, nylon, round, black	8
218	---	MANIFOLD, assembly, air (see page 79)	1	242	---	TUBE, 0.275 in. ID black nylon	5.5
219	26C587	SENSOR ASSEMBLY, level	2	243	115313	PLUG, tube	6
220	24P835	PUMP, diaphragm	1	244	126900	FITTING, 1/2 tube x 3/8 npt(m)	1
221	100016	WASHER, lock	4	246	215241	HOSE, 3/4 in. x 6 ft, 6000 psi (41 MPa, 410 bar)	1
222	102040	NUT, lock, hex	4	247	16T244	VALVE, pressure relief, 3/4 in. female npt	1
223	---	PANEL, assembly, air, all (A) side supply modules, page 81	1	248	---	TIE, cable, 14 in.	20
	---	PANEL, assembly, air, Model 24Y098 (B) side, page 81	1	249	108126	FITTING, tee, street	1
224	113796	SCREW, flanged, hex head	8	250	126899	FITTING, compression, straight	2
225	16R871	BOTTLE, overflow, 1/2 npt	1	251	112782	ELBOW, swivel, 90 degree	1
226	245869	HEATER, Viscon, non-hazardous area (A) side only, Model 24Y097	1	252	126897	FITTING, elbow	2
	245863	HEATER, Viscon; (A) side hazardous area unit	1	253	115764	FITTING, elbow, 90 degree	1
227◆	262868	SUPPLY, unit, 40:1, 0 volt, S20, 20L	1	254	190451	UNION, adapter	2
227a	26C434	PUMP AND MOTOR, see pump manual	1	255	---	LABEL, part description	1
				257	116395	FITTING, swivel, elbow	1
				258	103656	FITTING, pipe, hex	1
				259	198171	FITTING, elbow	1
				260	593538	VALVE, shuttle 1/8 nptf	1
				261	112781	ELBOW, swivel, 90 degree	1
				262	24K976	MUFFLER, 1/4 npt	1
				263	100505	BUSHING, pipe	1
				264	155665	UNION, adapter	1
				265	16R985	FITTING, nipple, 2 npt	1

Ref.	Part	Description	Qty.	
266	16R983	FITTING, adapter, 2 npt to 3/4 npt	1	--- Not for sale.
267	24P837	GASKET, agitator	1	◆ See Supply Systems manuals 313526 and 313527 for detailed instructions and parts list for the S20 Supply Unit (262868).
268	210575	CAP, filler	1	★ Included in radar level sensor kit 26C587. See Replace Radar Level Sensor on page 30.
269	16T245	COUPLING, shaft, one piece clamp	1	** Included in pressure tank assembly 24M683.
270	26C543	BLADE, agitator	1	NOTE: 26C587 Level sensor with the blue head replaces the 24P884 sensor with the red head. 26C587 includes (298).
272	102726	PLUG, pipe headless	1	
273	109212	SCREW, socket cap head	1	
274	115219	FITTING, tee, 1/4 npt	1	
275	262820	KIT, fluid outlet, flexible; see page page 83	1	
276	126900	CONNECTOR, male	1	
277	126692	CONNECTOR, male	1	
282	122327	FITTING, elbow, street; 3/4-14 npt	1	
296	156172	FITTING, union, swivel	1	
297	260067	FITTING, strain relief	1	
298★	127172	CABLE, M12, 5-pin, 4-wire	1	
299	102726	PLUG, pipe, headless	1	
300	117571	GASKET, santoprene	1	
320	17D307	FITTING, nipple, quick coupling	1	
321	159239	FITTING, nipple, pipe, reducing	1	
322	158683	FITTING, elbow, 90 degree	1	
323	17D024	BRACKET, mount, Viscon Heater	1	
324	121488	SCREW, hex head, flanged	2	
325	24Y438	CABLE, assembly, armored, (non-hazardous), (A) side only	1	
	24W679	CABLE, assembly, hazardous area (A) side only	1	
326	126896	ELBOW, 1/2 in. tube x 1/2 nptf	1	
327**	420036	CLAMP, pressure pot	6	

Heated Hose Bundle

16T121 - 3/4 in. x 1/2 in.

16T122 - 3/4 in. x 3/4 in.

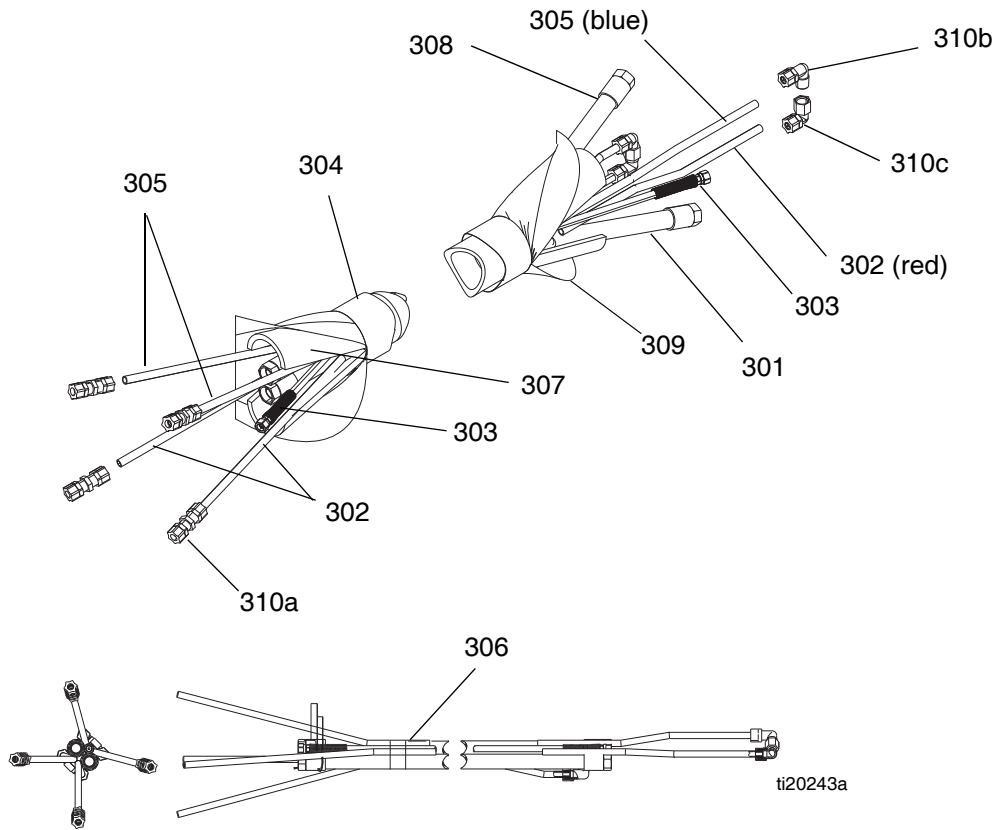

Ref.	Part	Description	Qty.	Ref.	Part	Description	Qty.
301	H77550	HOSE, coupled, 3/4 in., 6500 psi Model 16T121	1	311◆	16U111	KIT, fittings, hose connection	1
		Model 16T122	2	311a◆	C20487	NIPPLE, hex	2
302	16X027	KIT, tube, 0.375 (9.5mm) ID red nylon	2	311b◆	158491	NIPPLE	1
303	H42550	HOSE, coupled, 4500 psi, 1/4 in. ID, 50 ft (15.2 m)	1	311c◆	156823	UNION, swivel	2
304	---	LABEL, identification	1	311d◆	156971	NIPPLE, short	1
305	16X028	KIT, tube, 0.375 in. (9.5mm) ID blue nylon	2			--- <i>Not for sale.</i>	
306	---	TAPE, electrical	1			◆ <i>Not shown.</i>	
307	---	TUBE, insulation, 2-5/8 in. ID, 50 ft (15.2 m)	1				
308	H75050	HOSE, coupled, 7250 psi, 1/2 in. ID, 50 ft (15.2 m); <i>Model 16T121 only</i>	1				
309	16T138	JACKET, scuff, 50 ft (15.2 m)	1				
310	16U666	KIT, tube fittings	1				
310a	126894	UNION, 1/2 in. tube x 1/2 in. tube	4				
310b	126898	ELBOW, 1/2 in. tube x 1/2 nptm	2				
310c	126896	ELBOW, 1/2 in. tube x 1/2 nptf	2				

Base System (262878, 262941) Subassemblies

System Air Controls Module (255761)

NOTE: For Feed Module Air Panel (262860) parts, see page 81.

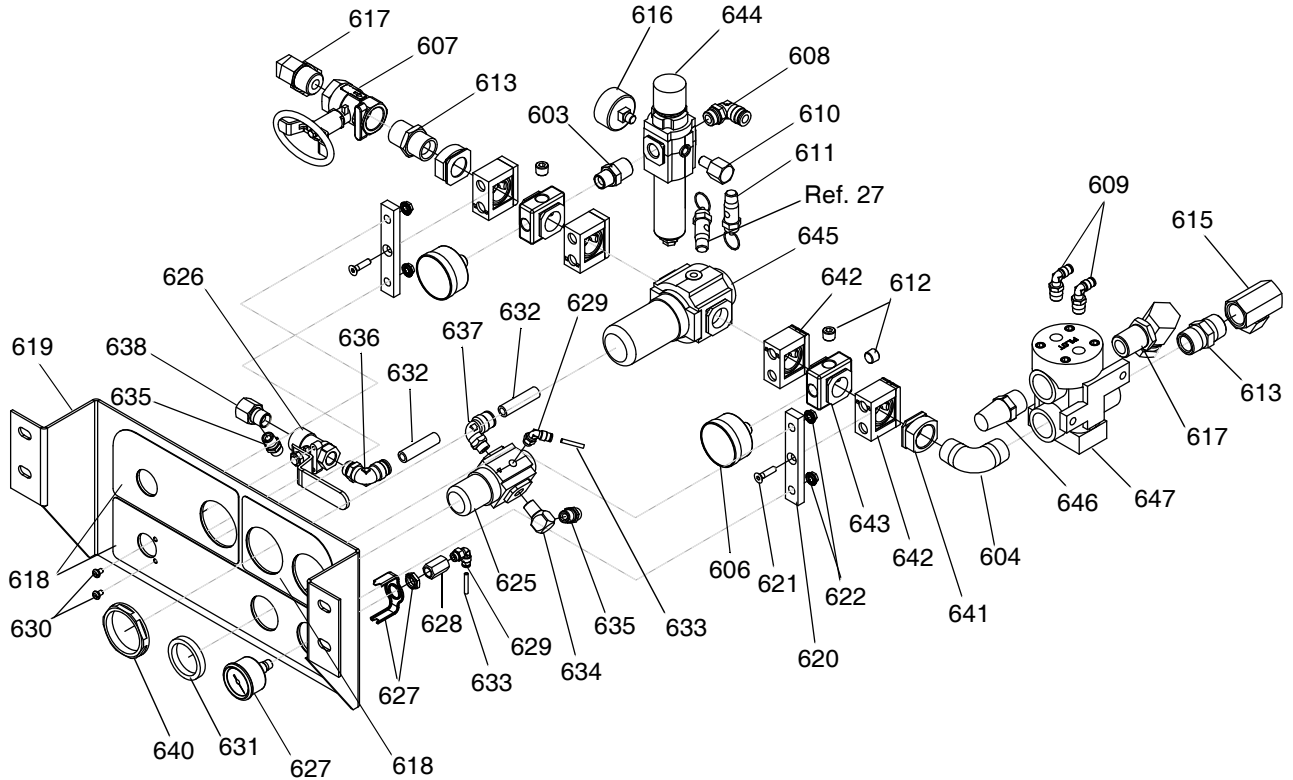

Ref.	Part	Description	Qty.	Ref.	Part	Description	Qty.
603	157350	NIPPLE, pipe; 1/2 x 3/8 npt	1	629	114151	ELBOW, male, swivel	2
604	108307	ELBOW, pipe, male	1	630	100264	SCREW, machine, pan head	2
606	101689	GAUGE, press, air	2	631	116514	NUT, regulator	1
607	117346	VALVE, ball, vented	1	632	054760	TUBE, polyurethane, round, black; 1.25 in.	-
608	114316	ELBOW, male, swivel	1	633	---	TUBE, polyurethane, round; 0.6 ft.	-
609*	114109	ELBOW, male, swivel; 1/4 OD tube	2	634	100840	ELBOW, street	1
610	158962	ELBOW, street; 1/4(f) x 1/8(m)	1	635	162453	FITTING; 1/4 npsm x 1/4 npt	2
611	116643	VALVE, safety, relief, air	1	636	114114	ELBOW, male, swivel	1
612	100721	PLUG, pipe	3	637	114128	ELBOW, male, swivel	1
613	119992	PIPE, nipple; 3/4 x 3/4 npt	2	638	164259	ELBOW, street	1
615	156589	ADAPTER, union; 90 deg.	1	640★	122336	NUT, panel, regulator	1
616	113911	GAUGE, pressure, air	1	641★	113440	ADAPTER	2
617	160327	ADAPTER, union; 90 deg.	2	642★	113431	CLAMP, quick	4
618	15T119	LABEL, control	1	643★	113442	BLOCK, porting	2
619	---	BRACKET, air controls	1	644★	15R488	REGULATOR	1
620	15R437	BRACKET, adapter, air controls	2	644a	123454	FILTER, element; 5 micron	1
621	121432	SCREW, machine, hex flat head	2	645★	15R487	REGULATOR	1
622	115942	NUT, hex, flange head	4	646★	15R486	MUFFLER	1
625	116513	REGULATOR, air	1	647★	15R485	VALVE, dual pilot	1
626	121457	VALVE, ball, air, panel mounted	1				
627	121424	GAUGE, pressure, panel mount, 1.5 in.	1				
628	100451	COUPLING	1				

★ Parts included in Air Controls Kit 255772 (purchase separately).

--- Not for sale.

Purge Box (Hazardous Area Machines)

Page 1 of 4

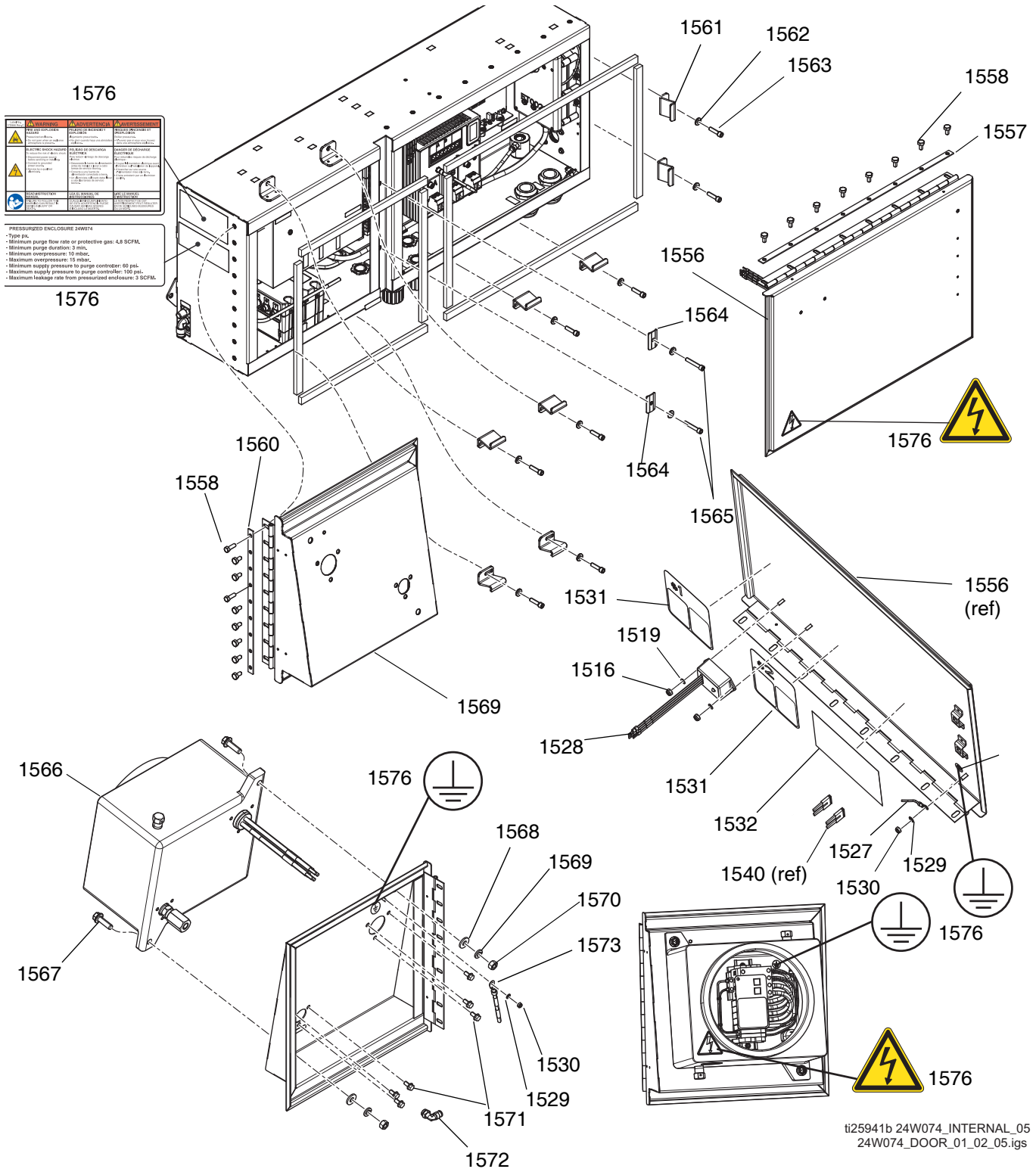

ti25941b 24W074_INTERNAL_05
24W074_DOOR_01_02_05.igs

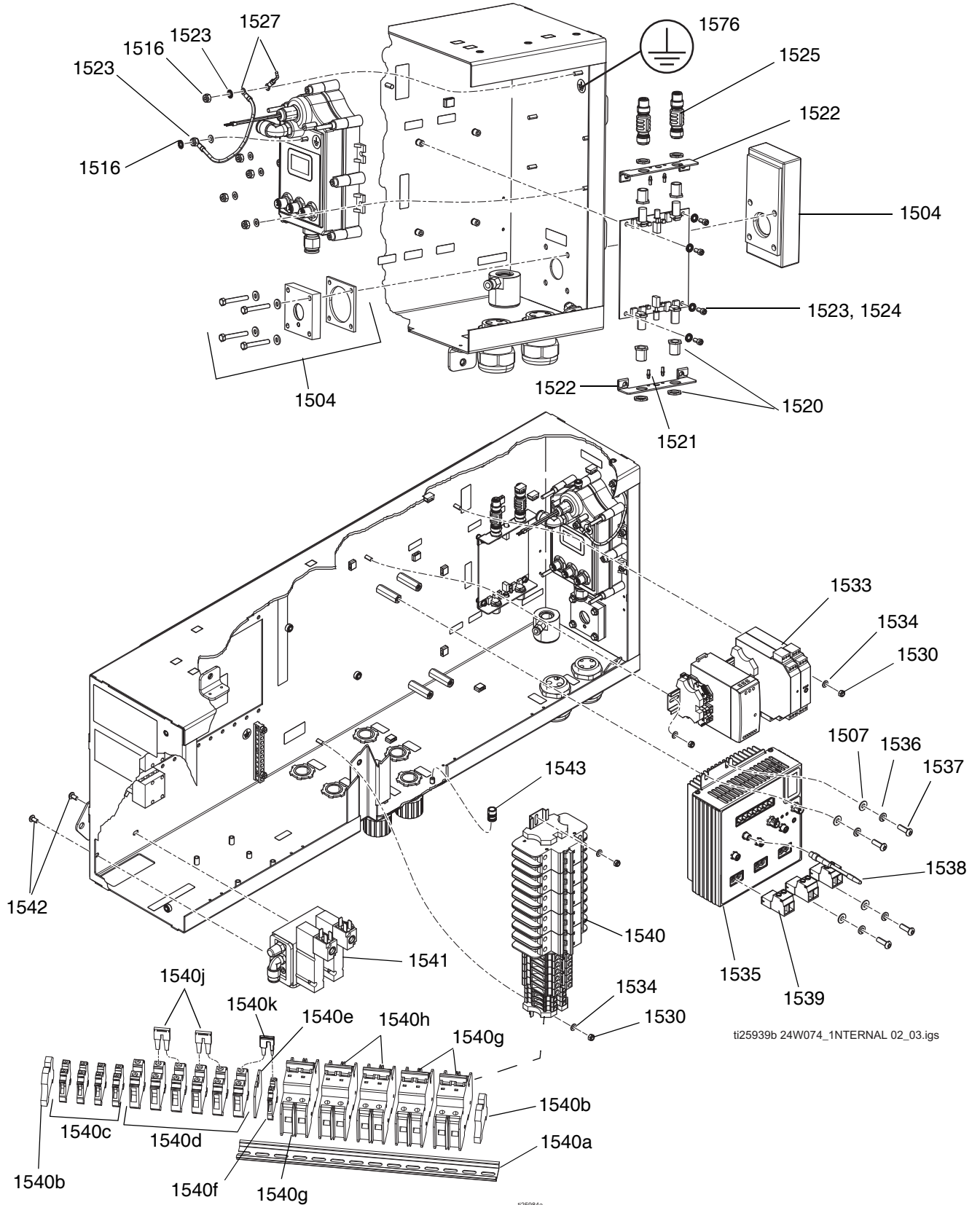

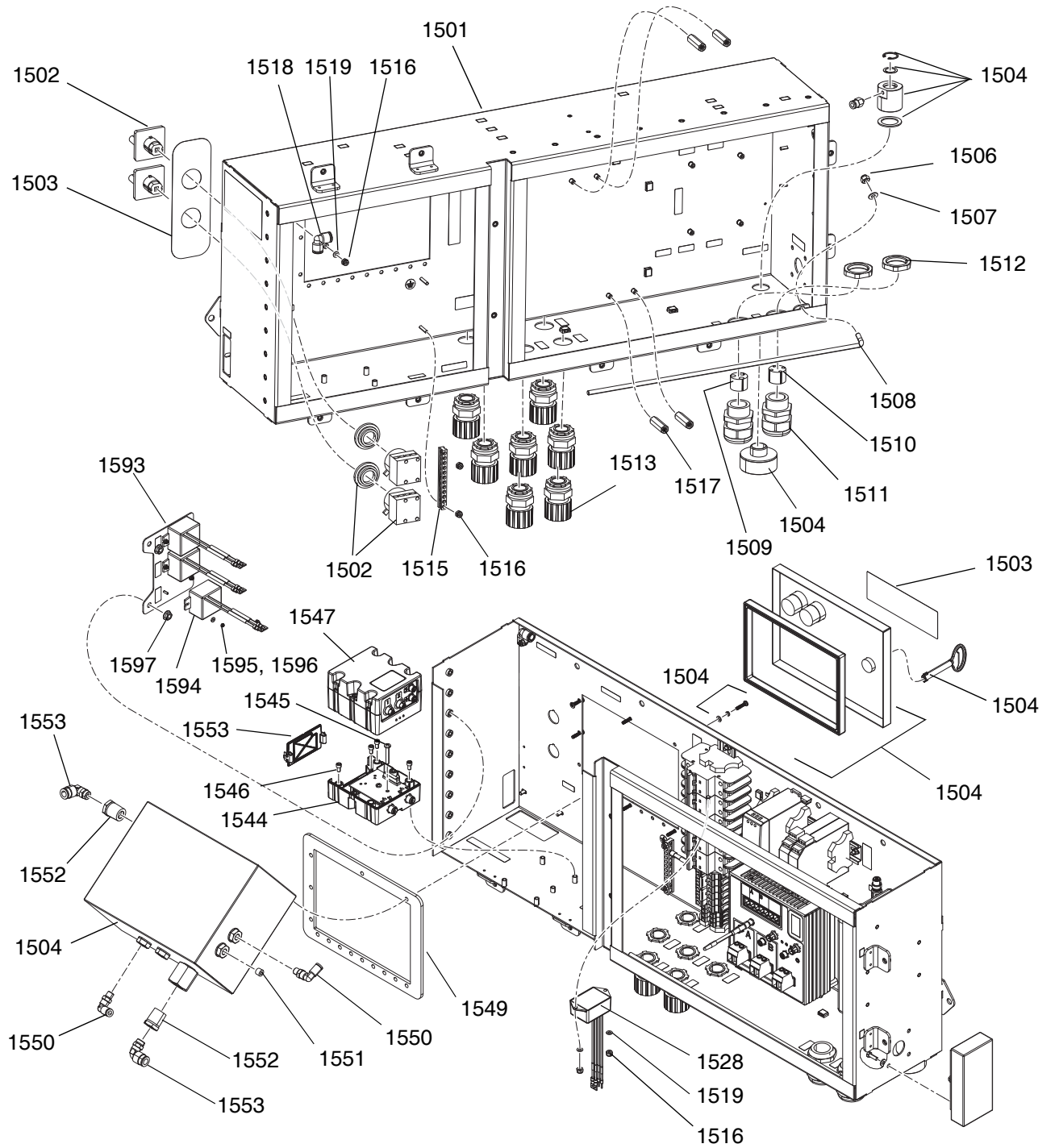

ti26761a 24W074_INTERNAL 01_04

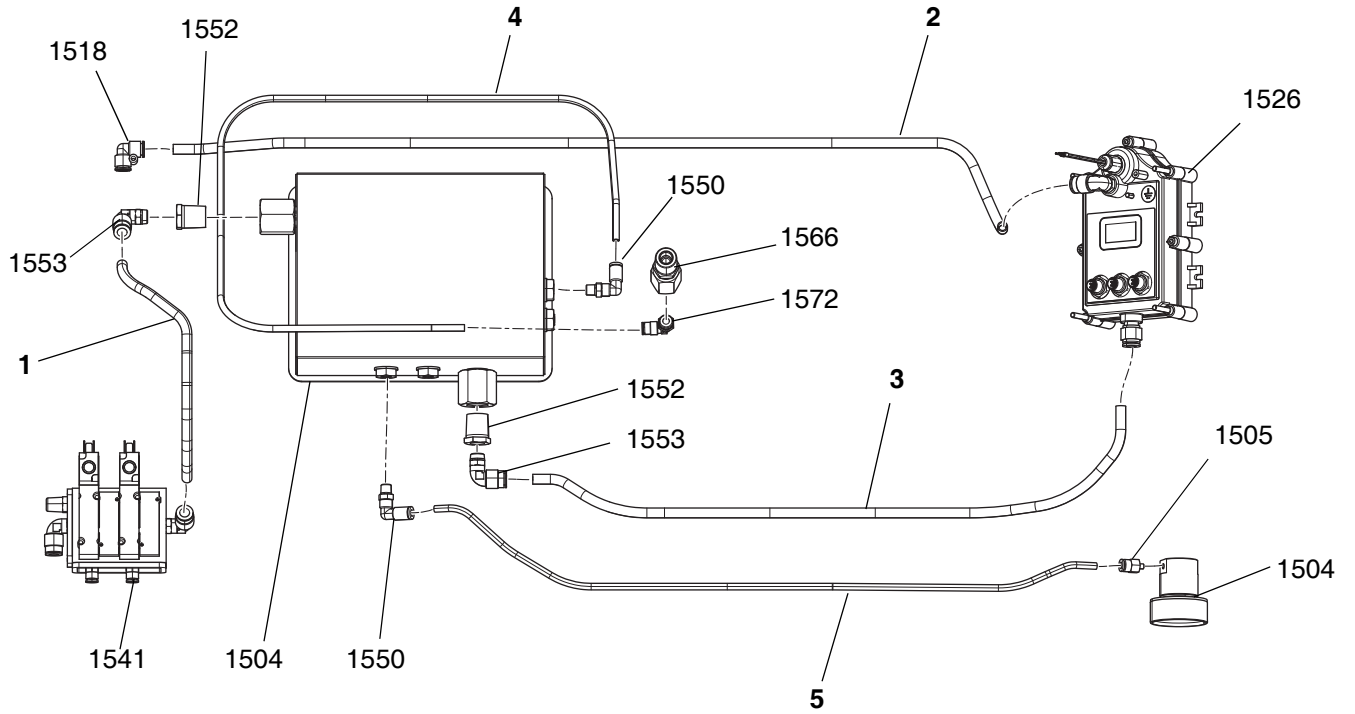

ti25945a 24W074_AIRLINES

Tubing	Ref	Length in (mm)
1	1574	13 (330.2)
2		35 (889)
3	1575	26 (660.)
4		39 (990.6)
5		30 (762)

Purge Box (Hazardous Area Machines)

Ref.	Part	Description	Qty.	Ref.	Part	Description	Qty.
1501	24W069	ENCLOSURE	1	1539	24R754	CONNECTOR, power, male, 2 pin	3
1502	15U423	SWITCH, 2P, 25A	2	1540	24X085	RAIL, purge, circuit breakers; includes 1540a-1540k	1
1503	17D815	LABEL, purge box, XM PFP, haz loc	1	1540a	514014	RAIL	1
1504	17D465	CONTROL BOX, purge	1	1540b	120838	BLOCK, clamp end	2
1505	114332	FITTING, connector, male	1	1540c	17D195	BLOCK, terminal	4
1506	102040	NUT, lock, hex	1	1540d	126382	COVER, end	6
1507	100086	WASHER, plain	5	1540e	24X086	BLOCK, terminal, 2 cond, 6.2 mm	1
1508	24W820	BRACE, prop, door	1	1540f	17A314	CIRCUIT, breaker, 2P, 20A, UL489, AB	1
1509	127837	GROMMET, CAN, 3 cable	1	1540g	17A316	CIRCUIT, breaker, 2P, 30A, UL489, AB	3
1510	127838	GROMMET, sensor, 4 cable	1	1540h	126384	BRIDGE, plug-in, jumper	
1511	126881	BUSHING, strain relief	2	1540j	24X087	BRIDGE, plug-in jumper, reducing	2
1512	126891	NUT, bushing	2	1540k	24R755	CONNECTOR, power, female, 7 pin	1
1513	16M826	CORD, grip, 3/4 in	7	1541	17C056	MODULE, solenoid, pfp, exp proof	1
1515	122313	BAR, ground, kit	1	1542	106084	SCREW, mach, pnh	2
1516	109466	NUT, lock, hex	13	1543	24W821	MAGNET, prop, door	1
1517	17D464	NUT, coupling, hex, 1/4-20 x 1.5	4	1544	289697	MODULE, GCA, cube, base	1
1518	17D466	FITTING, push connect, 3/8 3/8 90	1	1545	126687	SCREW, mach, pnh	1
1519	107584	WASHER, plain	10	1546	104371	SCREW, cap sch; 10 x.375	4
1520	24M485	BOARD, assy, GCA, CAN ISO, IS	1	1547	289696	MODULE, GCA, cube, FCM	1
1521	121645	LIGHT	4	1548	277674	ENCLOSURE, cube door	1
1522	16N621	BRACKET, board, circuit	2	1549	24W073	GASKET, controller, purge	1
1523	102063	WASHER, lock, ext	6	1550	112781	ELBOW, swivel,90°	2
1524	103229	SCREW, cap sch	4	1551	100139	PLUG, pipe	1
1525	16T072	ADAPTER, cable, CAN,IS TO NON IS	2	1552	100206	BUSHING, pipe	2
1526	24W610	MODULE, XMPFP, exp atmosphere	1	1553	115841	FITTING, elbow	2
1527	194337	WIRE, grounding, door	2	1555	17B838	STRIP, foam neoprene 0.313 x .625	9.5
1528	16U530	MODULE, surge protector	2	1556	24W052	ENCLOSURE, door, large	1
1529	100718	WASHER	2	1557	24W070	ENCLOSURE, hinge, backer, long	1
1530	115483	NUT, lock	6	1558	100333	SCREW, cap, hex hd	17
1531	17D814	LABEL, power, XM PFP, haz loc	1	1559	24W054	ENCLOSURE, door, small	1
1532	127111	ENVELOPE, packing, self-adhesive	1				
1533	17D228	RAIL, purge, haz loc, isolation	1				
1534	116876	WASHER, flat	4				
1535	24Y169	MODULE, gca, mzhp	1				
1536	100016	WASHER, lock	4				
1537	112689	SCREW, button hd	4				
1538	24U109	CABLE, over-temp, switch short	1				

Ref.	Part	Description	Qty.	Ref.	Part	Description	Qty.
1560	24W072	ENCLOSURE, hinge, backer, short	1	1593	17F587	BRACKET, line filter	1
1561	17C058	LATCH, enclosure, hd	8	1594	17F662	FILTER, line, ssr, assembly	3
1562	331103	WASHER, washer	10	1595	188773	WASHER, flat	6
1563	C19810	SCREW, cap, socket hd	8	1596	C27076	NUT	6
1564	24W116	LATCH, enclosure, center	2	1597	115942	NUT, hew, flange head	2
1565	596936	SCREW, cap, socket hd, 1/4 x 1.5	2	--- Not for sale.			
1566	17B850	BOX, power, explosion proof, page 70	1	▲ Replacement Danger and Warning labels, tags and cards are available at no cost.			
1567	124431	SCREW, head, washer, hex, 3/8-16	2				
1568	100023	WASHER, flat	2				
1569	100133	WASHER, lock, 3/8	2				
1570	100307	NUT, hex	2				
1571	113161	SCREW, flange, hex hd	6				
1572	114109	FITTING, elbow, male, swivel	1				
1573	17D194	CABLE, ground, box, purge	1				
1574	C12508	TUBING, nylon, round	6.2				
1575	054172	TUBE, nylon, rd	5.75				
1576▲	17D866	LABEL, safety, purge box, multi	1				
1577	121000	CABLE, CAN, f x f, 0.5m	1				
1578	121806	CABLE, solenoid	2				
1579	127068	CABLE, CAN, female/female 1.0m	2				
1580	17D197	CABLE, sensor, ISO to level, A	1				
1581	17D198	CABLE, sensor, ISO to level, B	1				
1582	17D199	CABLE, sensor, ISO to RTD, hose	1				
1583	17D200	CABLE, sensor, ISO to RTD, heater	1				
1584	17D201	CABLE, sensor, ISO to FCM 3, tank level	1				
1585	17D202	CABLE, sensor, ISO to FCM3, RTD	1				
1586	17D257	CABLE, I.S. CAN, fem-fem, 1.5m	1				
1587	17D260	CABLE, GCA, I.S., CAN, m/f, 1.6m	1				
1588	17D261	CABLE, male A to fem B code, 1.9m	1				
1589	24R735	CABLE, CAN power, m12 fem, pigtail	1				
1590	17D867	LABEL, cord wrap, XM PFP, haz loc	1				
1591	125871	TIE, cable, 7.5 in	21				

Explosion Proof Power Box (Hazardous Area Machines)

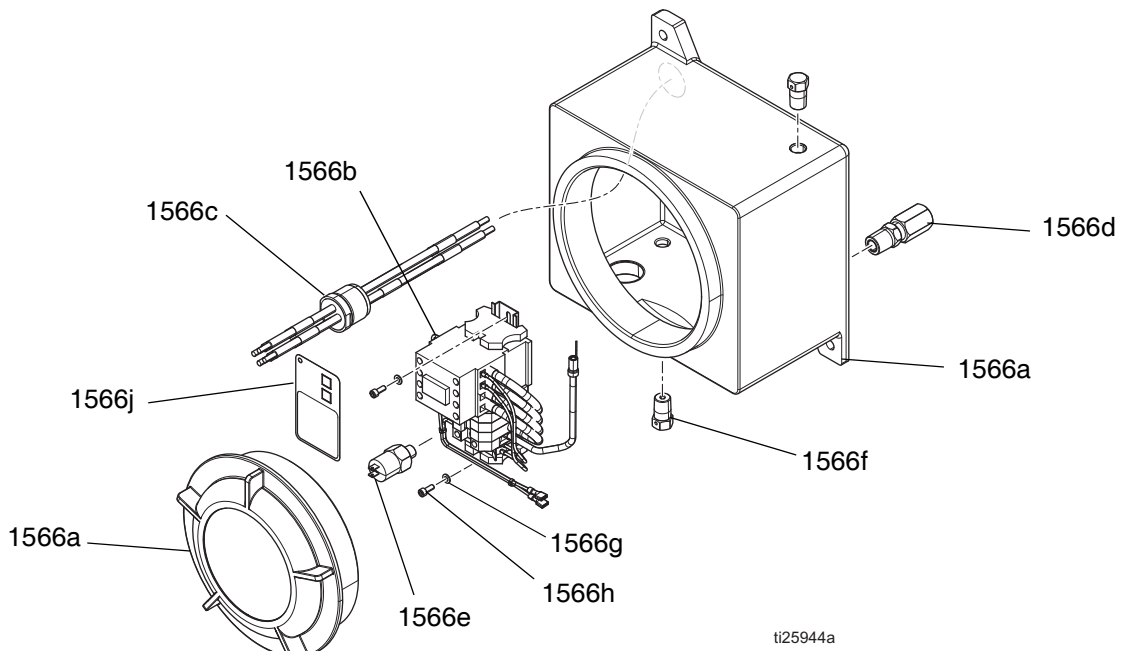

ti25944a

Ref.	Part	Description	Qty.
1566a	17B849	BOX, explosion proof	1
1566b	17B848	RAIL, power, disconnect	1
1566c	17B984	BUSHING, line	1
1566d	17B982	FITTING, arrester, flame	1
1566e	17B983	SWITCH, pressure	1
1566f	24X158	BREATHER, drain	2
1566g	116876	WASHER, flat	2
1566h	120039	FASTENER, schs, 10-32 x 1/2 in.	2
1566j	17D816	LABEL, hang tag, XM PFP, haz	1
1566k	125871	TIE, cable 7.5 in	1

Junction Box (Non-Hazardous Area Machines)

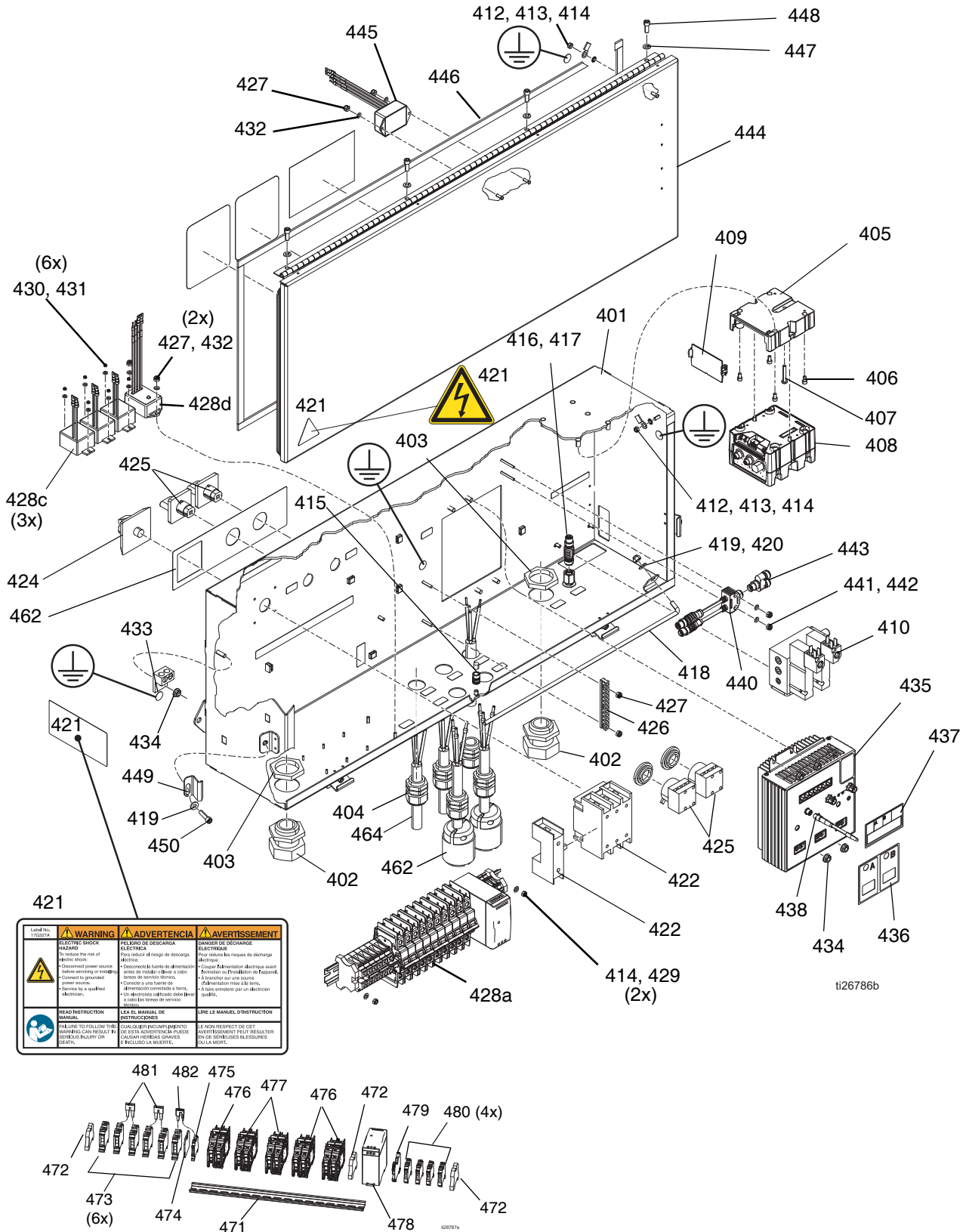

Parts

Junction Box (Non-Hazardous Area Machines)

Ref.	Part	Description	Qty.				
401	---	ENCLOSURE, weldment	1	435	24Y169	MODULE, gca, mzhp	1
402	120858	BUSHING, strain relief, m40 thread	2	436	17F844	LABEL, ID, multi-zone, lower a b	1
403	120859	NUT, strain relief, m40 thread	2	437	17F921	LABEL, ID, multi-zone, upper a b	1
404	121603	GRIP, cord,.51-.71,3/4	5	438	24R754	CONNECTOR, power, male, 2 pin	3
405	289697	MODULE, gca, cube, base	1	439	24U109	CABLE, over-temp, switch short	1
406	104371	SCREW, cap sch 10x.375	4	440	126495	CABLE, splitter, 4-20ma, 2 circuit	1
407	126687	SCREW, mach, pnh	1	441	151395	WASHER, flat	2
408	289696	MODULE, GCA, cube, FCM	1	442	C19862	NUT, lock, hex	1
409	277674	ENCLOSURE, cube door	1	443	124273	CONNECTOR, splitter	1
410	---	MODULE, solenoid, pfp	1	444	17G504	DOOR, weldment	1
410a	121636	VALVE, solenoid	2	445	16U530	MODULE, sys surge protector	1
410b	15A798	GASKET, outlet	1	446	070689	STRIP, foam, neoprene	8
410c	15A799	GASKET, inlet	1	447	100016	WASHER, lock	4
411	106084	SCREW, mach, pnh	2	448	121112	SCREW, cap, socket head	4
412	555629	WASHER, #10 external tooth lock	2	449	17G423	CLAMP, door latch	4
413	194337	WIRE, grounding, door	1	450	C19810	SCREW, cap, socket hd	4
414	115483	NUT, lock	4	451	24Y439	WIRE, chassis ground	1
415	24W821	MAGNET, prop, door	1	452	125789	CABLE, can, f x f, 0.5M	2
416	126496	CONNECTOR, thru, m12, mxf, reverse key	1	453	126494	CABLE, M12, 5p, 4 wire with drain	2
417	16T072	ADAPTER, cable, can, is to non is	1	454	121806	CABLE, solenoid	2
418	24W820	BRACE, prop, door	1	455	24R735	CABLE, can power, m12 fem, pigtail	1
419	331103	WASHER, washer .562 .250 .060 .st	5	456	126511	CABLE, gca, m8, 4-pin, 1.5m, m x f, mold	2
420	102040	NUT, lock, hex	1	457	125806	CABLE, splitter, m8, 4-pin, ffm 1.5M	1
421▲	17G327	LABEL, safety, junction	1	458	16T439	LABEL, cord wrap	1
422	123969	SWITCH, disconnect, 100 amp	1	460	125871	TIE,cable,7.50 inch	14
423	123968	SWITCH, disconnect, 100 amp	1	462	24Y480	CABLE, assembly, junction box	2
424	123967	KNOB, operator disconnect	1	464	24Y437	CABLE, assembly, Viscon heater	3
425	15U423	SWITCH, 2p, 25a	2	471	16T119	RAIL, mounting, 16 in.	1
426	122313	BAR, ground, kit	1	472	120838	BLOCK, clamp end	3
427	109466	NUT, lock, hex	6	473	126382	BLOCK, terminal	6
428	24Y446	RAIL, breaker assembly	1	474	126383	COVER, end	1
428a	24Y294	RAIL, circuit breaker (includes 471-482)	1	475	24X086	BLOCK, terminal, 2 cond, 6.2 mm	1
428b	24R755	CONNECTOR, power, female	1	476	17A314	CIRCUIT, breaker, 2P, 20A, UL489, AB	3
428c	17H081	FILTER, line, ssr assembly	3	477	17A316	CIRCUIT, breaker, 2P, 30A, UL489, AB	2
428d	16U530	MODULE, system surge protector	1	478	126453	POWER SUPPLY, 24V	1
428e	123410	FERRULE, wire, 10 awg	24	479	24R722	BLOCK, terminal PE, quad, AB	1
429	116876	WASHER, flat	2	480	17D195	BLOCK, terminal, 2 cond, 8.2 mm	4
430	188773	WASHER, flat	6	481	126384	BRIDGE, plug-in, jumper	2
431	C27076	NUT	6	482	24X087	BRIDGE, plug-in, jumper, rdng	1
432	107584	WASHER, plain	2	▲ Replacement Danger and Warning labels, tags and cards are available at no cost.			
433	117666	TERMINAL, ground	1	--- Not for sale. *Not shown.			
434	115942	NUT, hex, flange head	5	● Base electronic components do not have XM PFP-specific software installed. Therefore, use software upgrade token (506) to install software before use.			

† Includes software token (506) and instruction sheet.

Control Box (16)

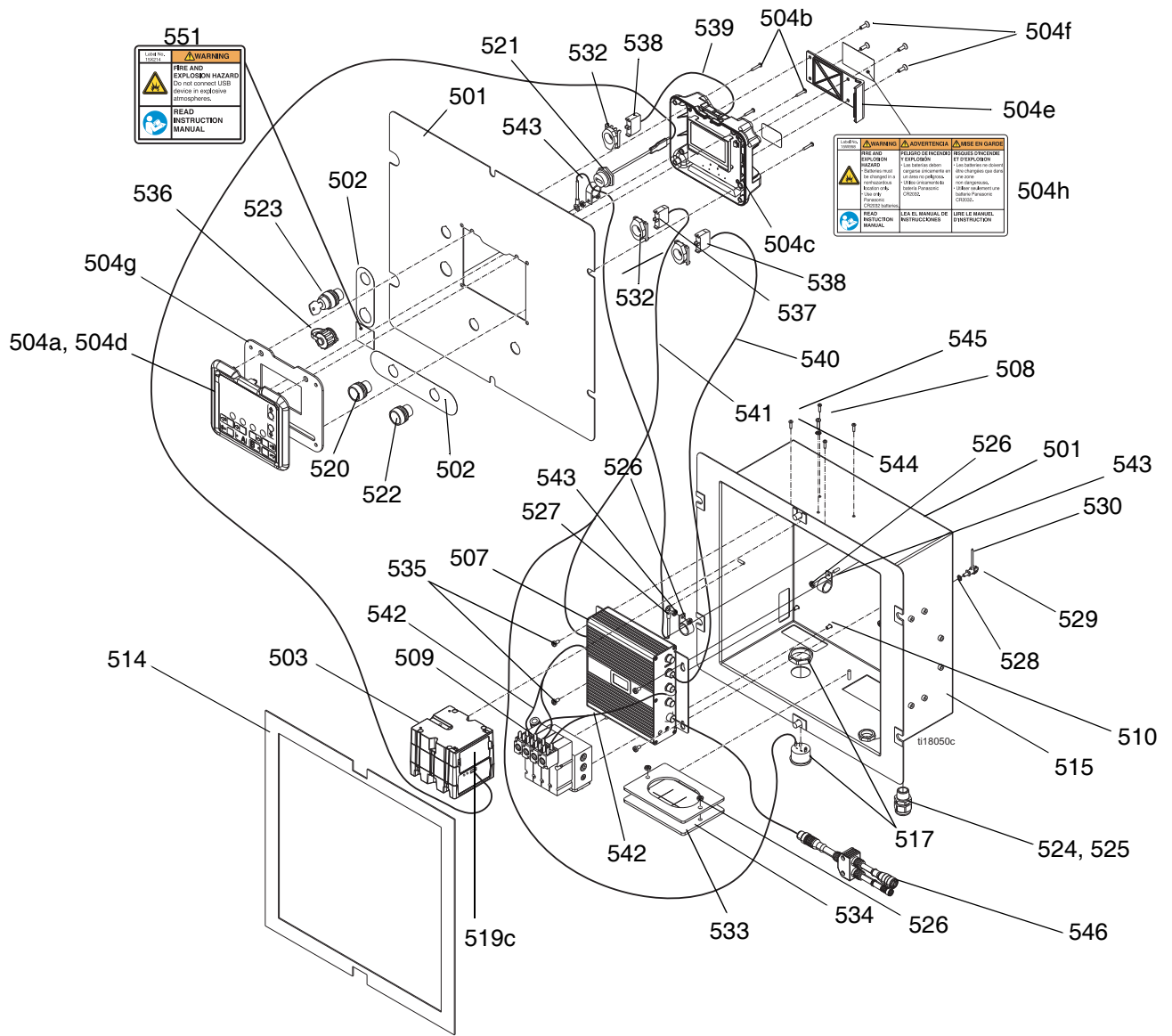



Parts

Ref.	Part	Description	Qty.	Ref.	Part	Description	Qty.
501	---	BOX, control	1	531*	172953	LABEL, designation	2
502	---	LABEL, control display	1	532	120493	LATCH, mounting	3
503†	262641	KIT, replacement, USB (includes 506, 519)	1	533	15H189	BOOT, wire feed through	1
504‡	257484	MODULE, display, kit	1	534	15G816	COVER, plate, wire	1
504a	15M483	SHIELD, membrane, display (qty. 10)	1	535	110637	SCREW, machine, pan head	4
504b	---	SCREW, pan hd, #6 x 7/8 in.	4	536	15R325	COVER, dust, bulkhead, receptacle	1
504c‡	288997	CASE, rear, display module, IS version	1	537	120494	BLOCK, switch, normally open	2
504d	255727	CASE, front, data module	1	538	120495	BLOCK, switch, normally closed	4
504e	277463	COVER, access, low level display	1	539	15M974	HARNESS, key switch	1
504f	113768	SCREW, socket, flat head	4	540	15M975	HARNESS, start/alarm	1
504g	15R458	GASKET, control, front	1	541	15M976	HARNESS, stop	1
504h	15W958	LABEL, warning, panel battery	1	542	15M977	HARNESS, solenoid	1
505†	262642	KIT, replacement, display (includes 504, 506)	1	543	121988	RETAINER, routing, wire harness	1
506	17E110	TOKEN, software	1	544	195875	SCREW, machine, pan head	1
507†	262643	KIT, replacement, FCM (includes 506, 518)	1	545	102063	WASHER, lock	1
508	---	SCREW, pan head	4	546	15U542	CABLE, motor	2
509	256555	MODULE, solenoid, IS version	1	551▲		LABEL, warning, lock	1
509a	121636	VALVE, solenoid, din connector	4		15X214	English	-
509b	15A798	GASKET, solenoid, outlet	1		15X393	LABEL, warning, USB	---
509c	15A799	GASKET, solenoid, inlet/exhaust	1	‡	122829	CONDUIT, 0.75 ft (not shown)	-
510	106084	SCREW, machine, pan head	2	▲ Replacement safety labels, tags, and cards are available at no cost.			
514	15R379	GASKET, box, control	1	--- Not for sale.			
515	---	LABEL	1	* Not shown.			
516*	15B056	LABEL, air motor/dosing valve	1	‡ Base electronic components do not have XM PFP-specific software installed. Therefore, use software upgrade token (506) to install software before use.			
517	122000	ALARM, panel mount	1	† Includes software token (506) and instruction sheet.			
518‡	255920	MODULE, fluid control	1				
519‡	257088	MODULE, USB, assy.	1				
519a	289899	BASE	1				
519b‡	289900	MODULE, USB	1				
519c	277674	DOOR, module	1				
520	121618	SWITCH, start, push button, green	1				
521	15R324	HARNESS, USB, plug/bulkhead; 32 in.	1				
522	121619	SWITCH, stop, push button, red	1				
523	121617	SWITCH, 2 position, key, controls	1				
523a*	123412	KEY, replacement	1				
524	117745	BUSHING, strain relief (pair)	1				
525	117625	NUT, locking	1				
526	113505	NUT, keps, hex head	6				
527	15B090	WIRE, grounding, door	1				
528	---	WASHER, lock, external, 1/4 in.	1				
529	15R343	CLAMP, ground, electrical	1				
530	---	WIRE, copper	3				

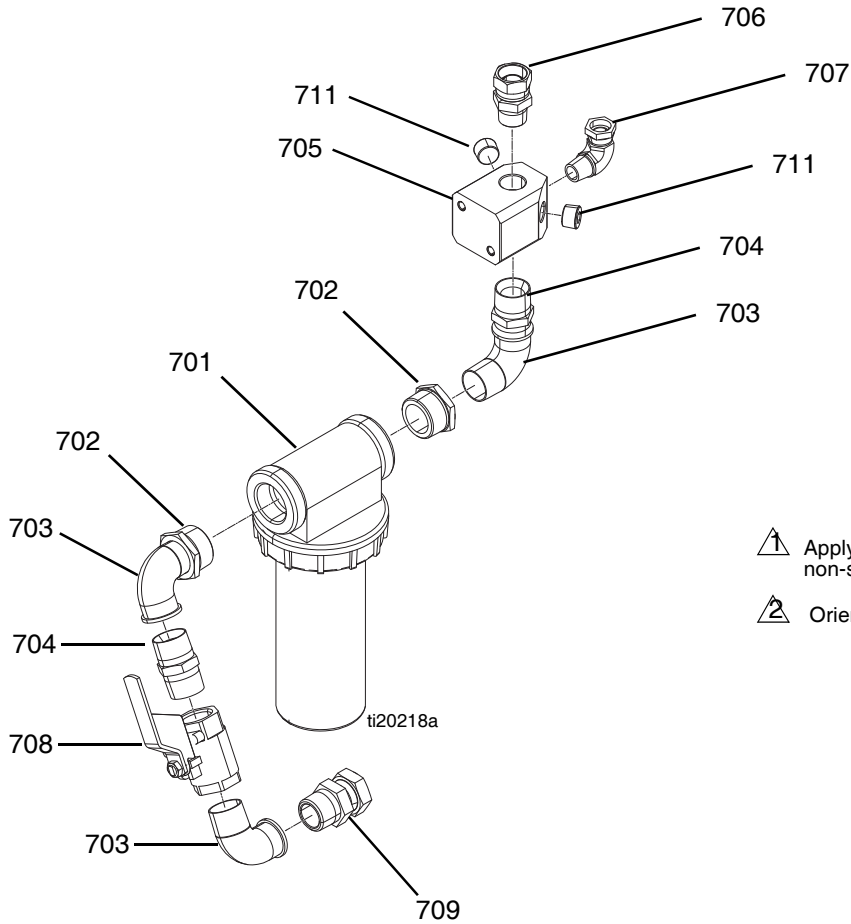
Air Filter (24P899)



-  Apply PTFE tape and/or pipe sealant to all non-swiveling pipe threads.
-  Orient fittings approximately as shown.

Ref.	Part	Description	Qty.
701	16T236	FILTER, air, 1-1/4, auto drain	1
701a◆	106204	FILTER ELEMENT	1
702	C19662	BUSHING, 1-1/4 x 1 npt carbon steel	2
703	110300	FITTING, elbow, street, pipe	3
704	158585	FITTING, nipple	2
705	16R951	MANIFOLD, air distribution	1
706	157785	FITTING, swivel	1
707	C19024	FITTING, elbow, swivel	1
708	113163	VALVE, ball, vented, 1.00 in.	1
709	160022	FITTING, union, adapter	1
710	---	SEALANT, pipe, stainless steel	1
711	100361	PLUG, pipe	2

--- Not for sale.

◆ Not shown.

Ratio Control Valve Assemblies (28, 29)

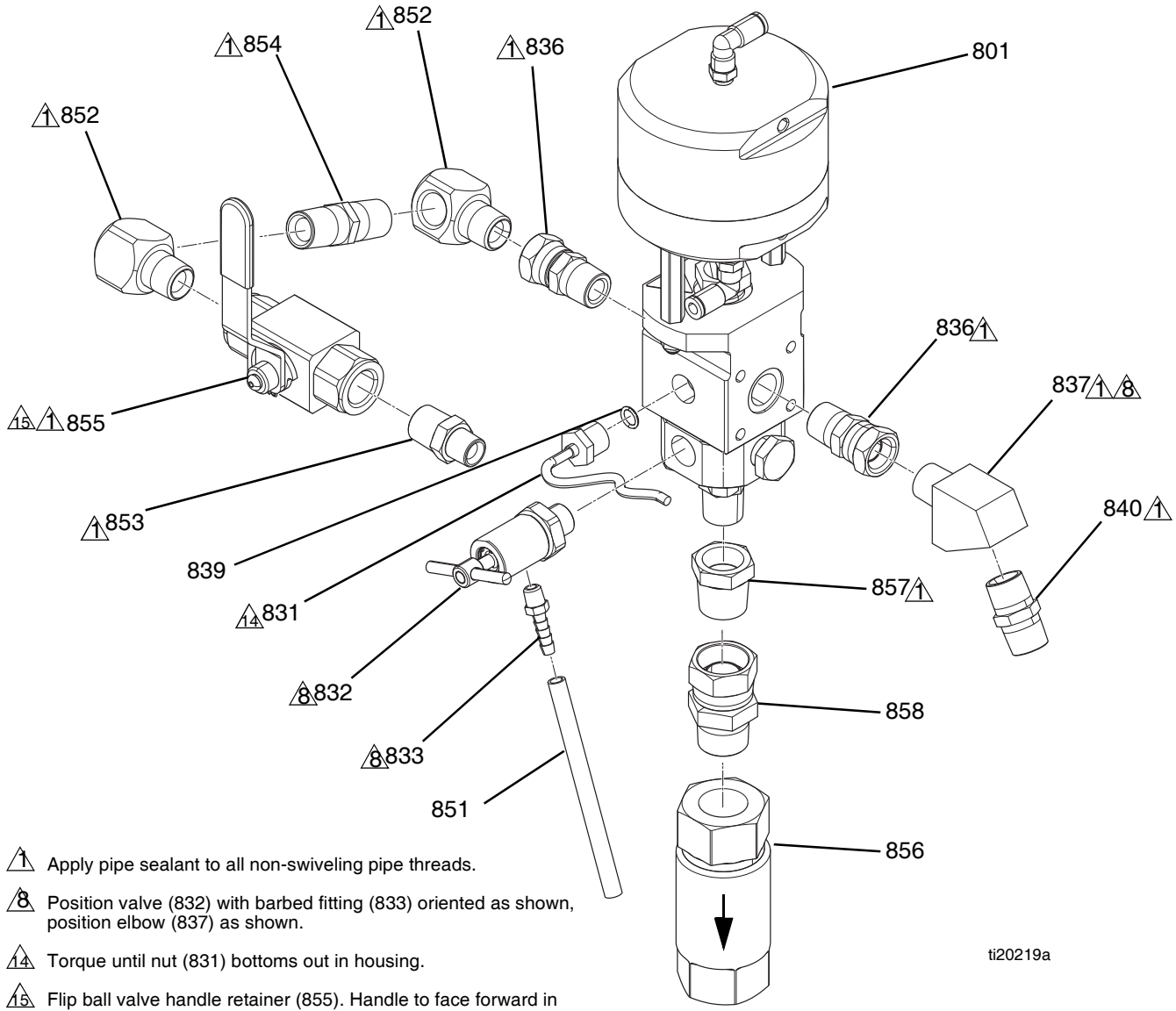

- ▲ Apply pipe sealant to all non-swiveling pipe threads.
- ⊗ Position valve (832) with barbed fitting (833) oriented as shown, position elbow (837) as shown.
- ▲ Torque until nut (831) bottoms out in housing.
- ▲ Flip ball valve handle retainer (855). Handle to face forward in open position.

ti20219a

Ref.	Part	Description	Qty.	Ref.	Part	Description	Qty.
801†	255478	VALVE, dosing	1	853	159239	FITTING, nipple, pipe, reducing (B side only)	1
831	15M669	SENSOR, pressure, fluid outlet	1	854	156877	FITTING, nipple, long	1
832	262872	VALVE, pressure, bleed, PFP	1	855	262739	VALVE, ball, 1/2 in.	1
833	116746	FITTING, barbed, plated	1	856	16T481	VALVE, check; see page 82	1
836	156684	FITTING, union, adapter	2	857	502033	FITTING, bushing, pipe	1
837	15M987	FITTING, elbow, 60 degree	1	858	157785	FITTING, swivel	1
839	121399	PACKING, o-ring	1				
840	158491	FITTING, nipple (B side only - Qty 1) (A side only - Qty 2)					
851	116750	TUBE, nylon	1				
852	158683	FITTING, elbow, 90 degree	2				

† See Dosing Valve Instructions - Parts manual referenced on page 4 for further details.

Feed Module Sub-Assemblies

Air Powered Agitator (24P885)

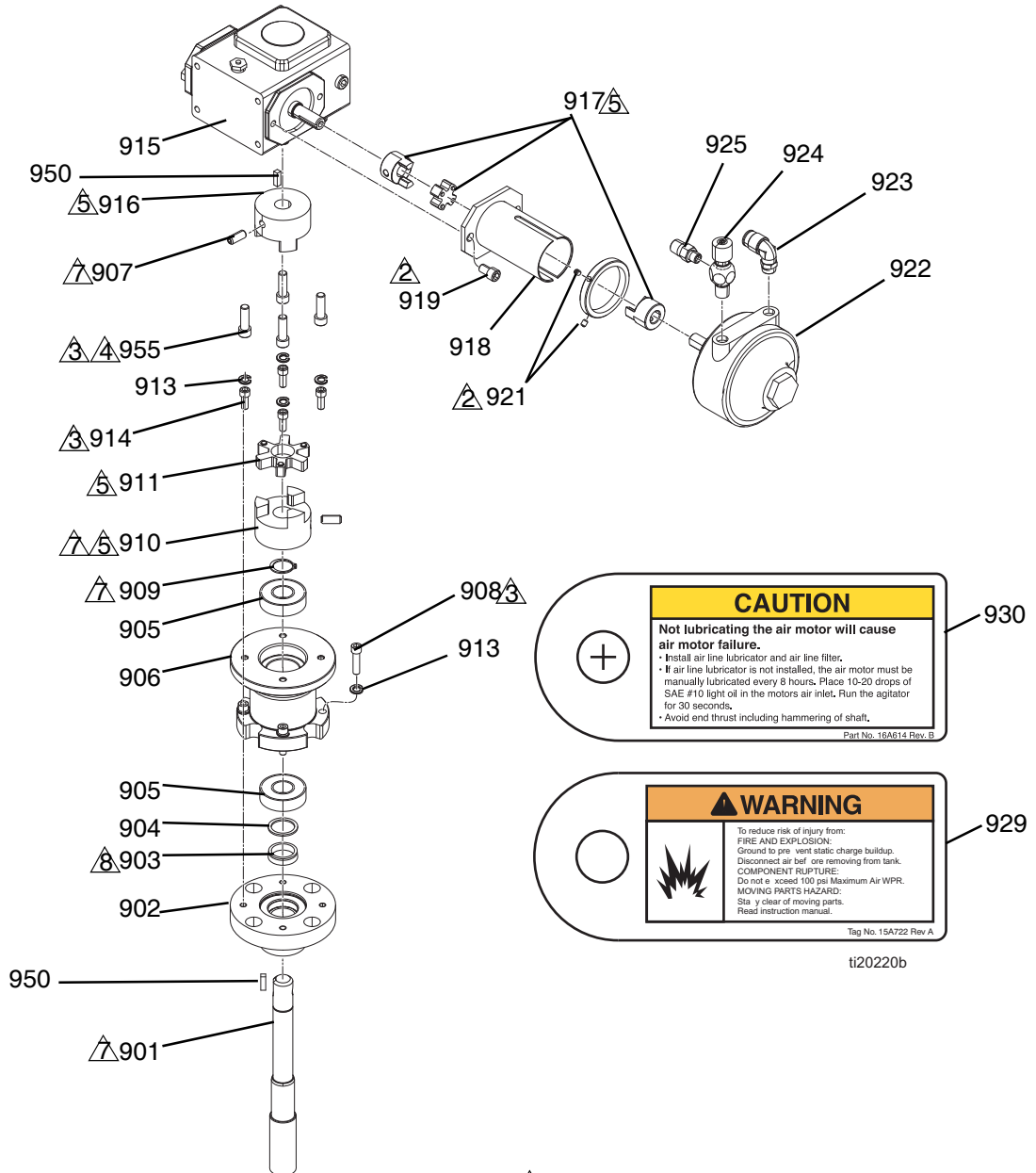

- 1 Apply pipe sealant to all non-swiveling pipe threads.
- 2 Apply low strength threadlocker.
- 3 Apply blue thread locker.
- 4 Remove four screws from gear reducer (915), pass them through bracket (912) and back into gear reducer (915) then torque to 150-170 in-lb (17-19 N•m).

- 5 Leave a 0.015 in. gap between each half of couplings (910, 911, 916, 917).
- 7 When ordering a replacement coupling: Remove set screw supplied with couplings (910, 916) and discard. Replace with set screw (931).
- 8 Open side of u-cup seal (903) must face down inside housing (902).

CAUTION

Not lubricating the air motor will cause air motor failure.

- Install air line lubricator and air line filter.
- If air line lubricator is not installed, the air motor must be manually lubricated every 8 hours. Place 10-20 drops of SAE #10 light oil in the motor's air inlet. Run the agitator for 30 seconds.
- Avoid end thrust including hammering of shaft.

Part No. 16A614 Rev. B

WARNING

To reduce risk of injury from:

FIRE AND EXPLOSION:
Ground to prevent static charge buildup. Disconnect air before removing from tank.

COMPONENT RUPTURE:
Do not exceed 100 psi Maximum Air WPR.

MOVING PARTS HAZARD:
Stay clear of moving parts. Read instruction manual.

Tag No. 15A722 Rev. A

ti20220b

Air Powered Agitator (24P885)

Ref.	Part	Description	Qty.
901	16P919	SHAFT, agitator, upper	1
902	16U219	HOUSING, agitator	1
903	122772	SEAL, 0.875 in. ID x 1.125 in. OD, PTFE	1
904	15Y360	SPACER, shaft, agitator, ASME	1
905	122774	BEARING, ball, 3/4bore x 1-3/4 dia. x 1/2	2
906	16P920	HOUSING, bearing, agitator	1
907	---	SCREW, socket head set screw, 5/16-18 x 0.75	2
908	112222	SCREW, socket cap head	4
909	122776	RING, retaining, external, 0.750 in.	1
910	122761	HOUSING, alignment, hub	1
911	122760	COUPLING, alignment, disk, TPE	1
912	16P922	BRACKET, adapter, agitator	1
913	C19209	WASHER, lock	8
914	101682	SCREW, socket cap head	4
915	181794	GEAR, reducer	1
916	16P923	COUPLER, adapter	1
917	100828	COUPLING, flexible	1
918	16T063	COLLAR, mounting	1
919	116940	SCREW, cap, socket head, 5/16-18	2
920	181849	COLLAR	1
921	101118	SCREW	2
922	111310	MOTOR, air, rotary	1
923	115841	FITTING, elbow	1
924	206264	VALVE, needle	1
925	191872	FITTING, nipple, reducing	1
926	---	SEALANT, pipe, stainless steel	1
927	---	SEALANT, low strength thread locker	1
928	---	SEALANT, blue thread locker	1
929▲	15A722	TAG, warning, agitator	1
930▲	16A614	TAG, label, caution	1
955	120376	KEY, square	2

--- Not for sale.

▲ Replacement Danger and Warning labels, tags and cards are available at no cost.

Tank Air Manifold Assembly (218)

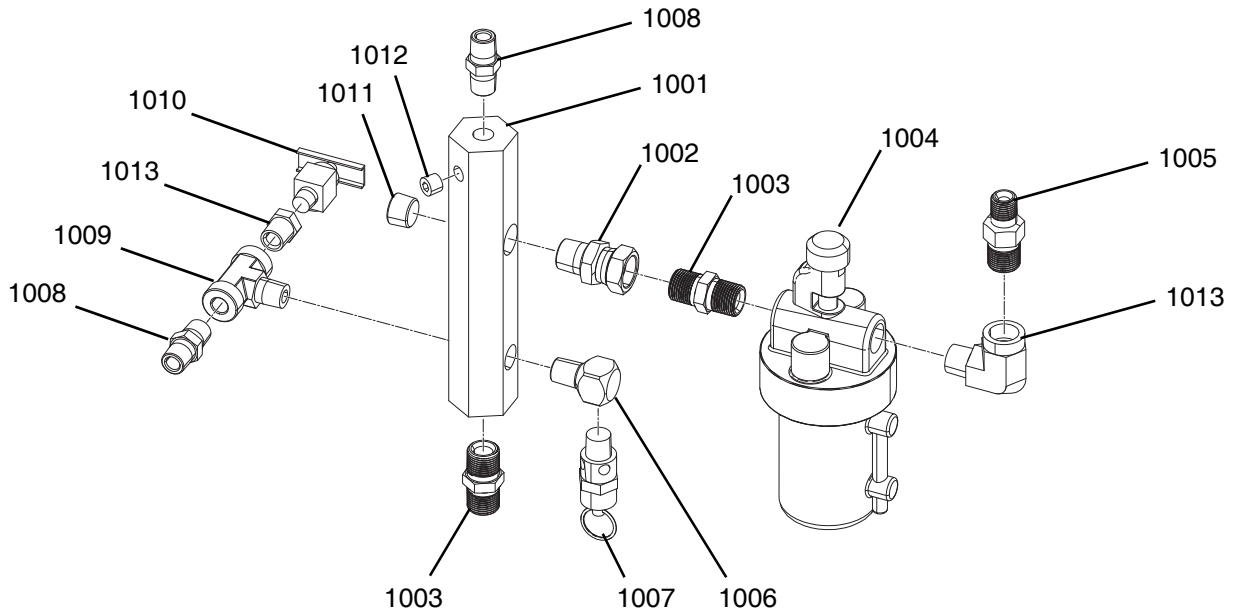



- Apply pipe sealant to all non-swiveling pipe threads.
- Orient all fittings as shown.

Ref.	Part	Description	Qty.
1001	189016	MANIFOLD, air, inlet	1
1002	155665	UNION, adapter	1
1003	156849	PIPE, nipple	2
1004	214847	LUBRICATOR, air line	1
1005	165198	FITTING, nipple, reducing	1
1006	100840	FITTING, elbow, street	1
1007	116643	VALVE, safety, 90 psi	1
1008	156971	FITTING, nipple, short	2
1009	108638	FITTING, pipe, tee	1
1010	101759	FITTING, drain cock	1
1011	101754	PLUG, pipe	1
1012	100139	PLUG, pipe	1
1013	100030	BUSHING	1
1014	111856	FITTING, elbow, street	1
1015	---	SEALANT, pipe, stainless steel	1

--- Not for sale.

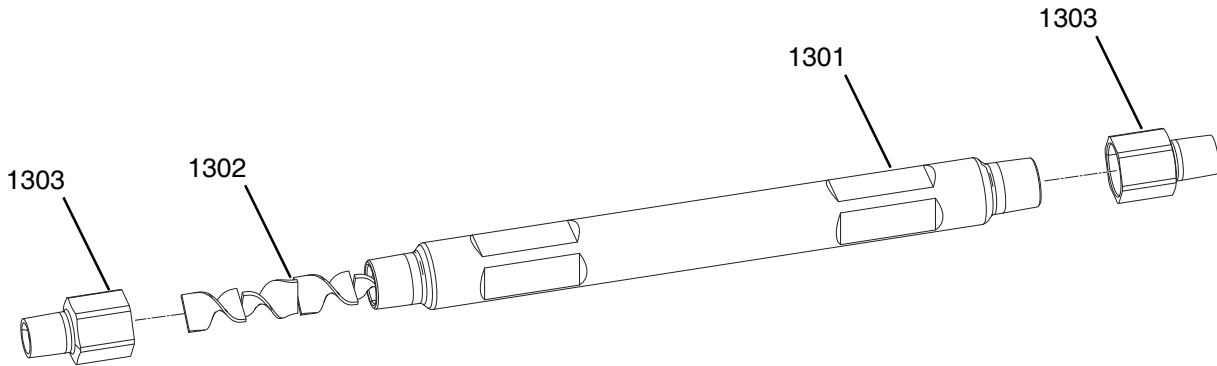
Static Mixer (16T316)



 Apply pipe sealant to all non-swiveling pipe threads.

Ref.	Part	Description	Qty.
1301	---	TUBE, mixer	1
1302	24P886	MIXER, 12 element, stainless steel	1
1303	16T315	BUSHING, reducing 3/4 nptf x 1/2 npt	2
1304	---	SEALANT, pipe, stainless steel	1

--- Not for sale.

Feed Module Air Panel (262860)

NOTE: For **System Air Controls Module (255761)** parts, see page 63.

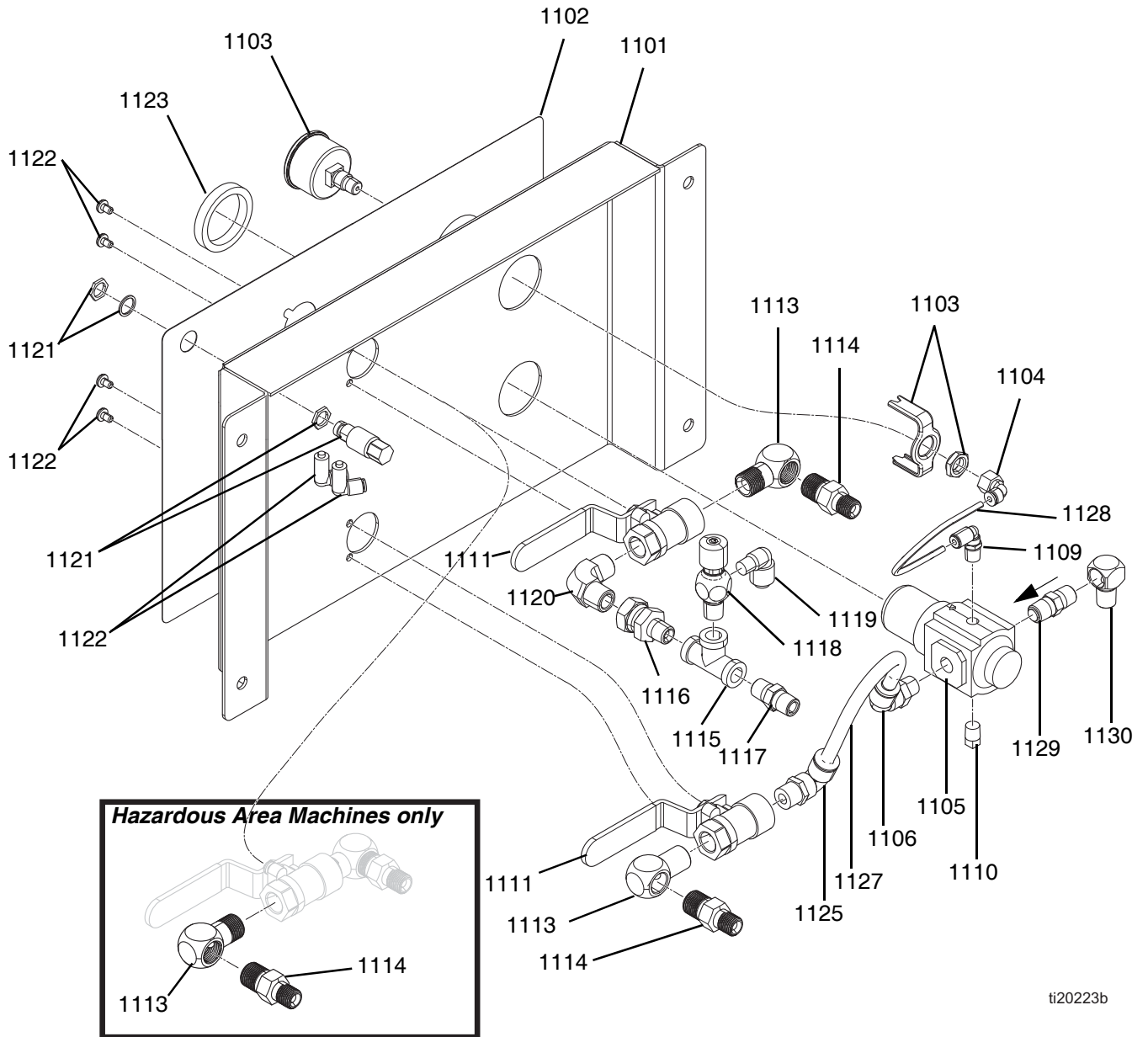

ti20223b

 Apply pipe sealant to all non-swiveling pipe threads.

Air Panel

Ref.	Part	Description	Qty.
1101	---	BRACKET, air control	1
1102	---	LABEL, instructions	1
1103	121424	GAUGE, pressure, panel mount, 1.5 in.	1
1104	15T498	FITTING, 90 degree, swivel, 5/32 in. tee x 1/8 in. female npt	1
1105	116513	REGULATOR, air	1
1106	121141	FITTING, elbow, swivel, 3/8 tee, 1/4 in. male npt	1
1109	198171	FITTING, elbow	1
1110	100403	PLUG, pipe	1
1111	121457	VALVE, ball, air, panel mounted	2
1113	155699	FITTING, elbow, street <i>262860: Qty 2) (262844: Qty. 3)</i>	
1114	165198	FITTING, nipple, reducing <i>(262860: Qty 2) (262844: Qty. 3)</i>	
1115	104984	FITTING, tee, pipe	1
1116	157705	UNION, swivel	1
1117	156971	FITTING, nipple, short	1
1118	206264	VALVE, needle	1
1119	114367	FITTING, tube, qd, 90 degree elbow	1
1120	109544	FITTING, elbow, pipe, male	1
1121	110914	VALVE, button, push	1
1122	100264	SCREW, mach, panhead	4
1123	116514	NUT, regulator mount	1
1124	109193	FITTING, tube, male, elbow	2
1125	16F151	FITTING, elbow, swivel, 3/8 tee, 3/8 npt	1
1126	---	SEALANT, pipe, stainless steel	1
1127	054134	TUBE, nylon, 3/8 in. OD	1.1
1128	517305	TUBE, nylon, 5/32 in. OD	0.7
1129	106495	VALVE, check, brass, 1/4 MBE	1
1130	100840	FITTING, elbow, street	1

--- Not for sale.

Check Valve (16T481)

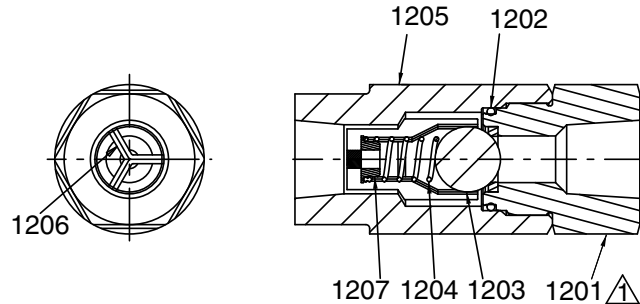
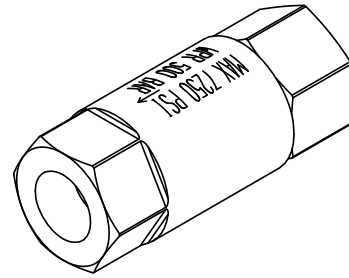

Torque to 75-80 ft-lb (102-108 N*m).

Ref.	Part	Description	Qty.
1201	---	NUT, seat	1
1202	102595	PACKING, o-ring	1
1203	100279	BALL, metallic	1
1204	108361	SPRING, compression	1
1205	---	HOUSING, ball check	1
1206	181492	GUIDE, ball	3
1207	181535	RETAINER, spring	1

--- Not for sale.

Flexible Fluid Connection Kit (262820)

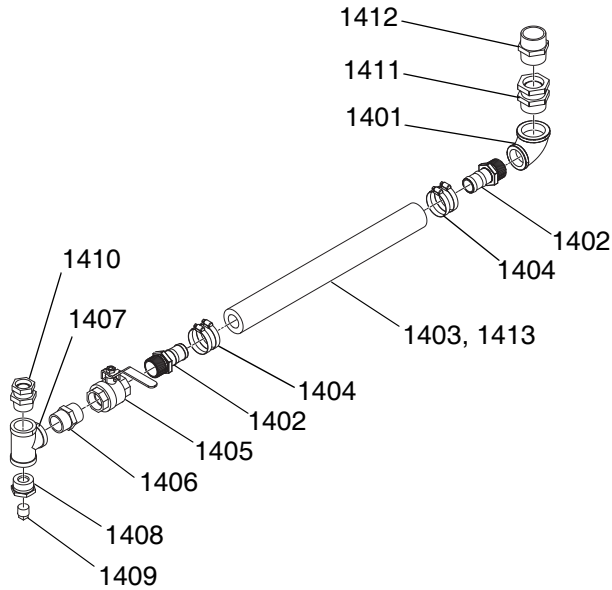

Accessories

Part	Description	Qty.
17G061	BAG, 100 pack, polyethylene, (see Batch Dispense or Ratio Test in sprayer Setup - Operation manual)	1
24P833	KIT, mix wetted parts, contains one set of spare parts from the mix manifold outlet to the spray tip.	1
24X113	KIT, hot water flush, for hazardous area machines, see form 332073	1
24Y132	KIT, hot water flush, for non-hazardous area machines, see form 332073	1

Ref.	Part	Description	Qty.
1401	120291	PIPE, elbow female	1
1402	125995	FITTING, hose, barbed, 1-1/2 npt	2
1403	126320	HOSE, 1-1/2 ID, 200 psi, 3 ft; for side to side configuration	1
1404	126889	CLAMP, hose	2
1405	121440	VALVE, ball, 1-1/2 npt	1
1406	121441	FITTING, nipple, hex, 1-1/2 npt	1
1407	121443	FITTING, tee, 1-1/2npt	1
1408	101496	BUSHING, pipe	1
1409	104663	PLUG, pipe	1
1410	121445	SWIVEL, reducing, 1-1/2 x 1-1/4	1
1411	121436	FITTING, swivel, male, 2 in.	1
1412	121435	FITTING, nipple, hex, 2 in.	1
1413	17D794	HOSE, 1-1/2 ID, 200 psi, 13 in; for front to back configuration	1

Dimensions

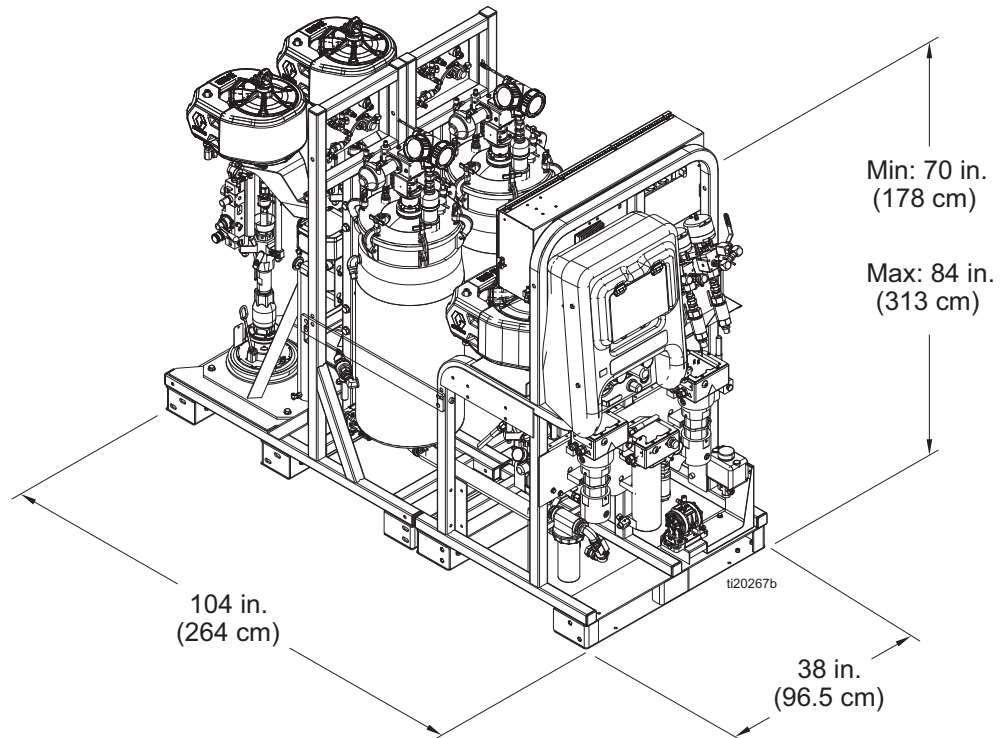
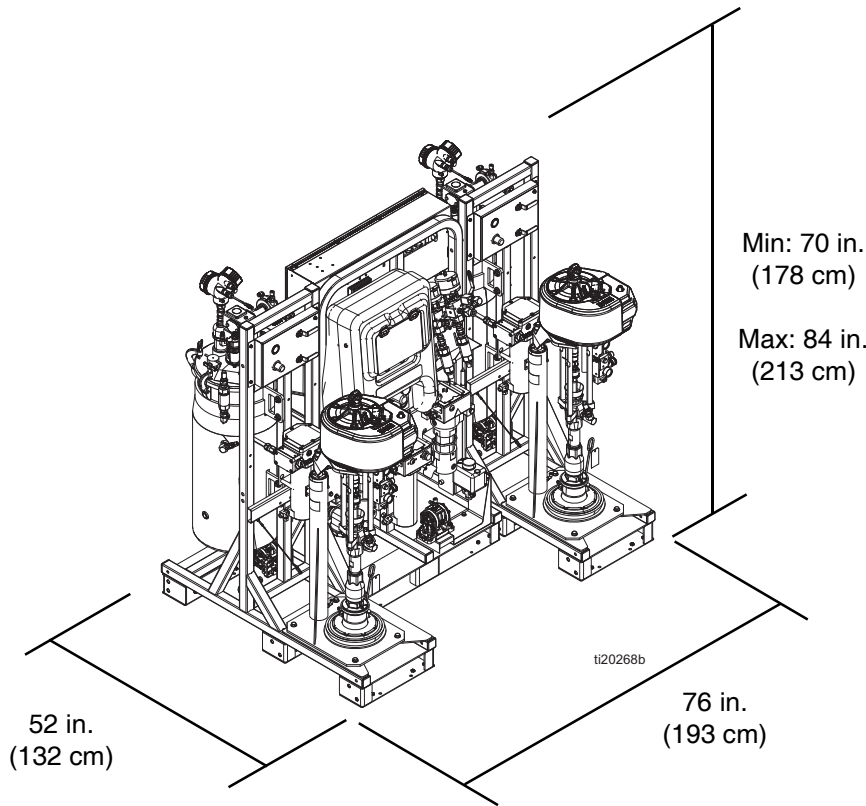

Technical Specifications

XM PFP		
	US	Metric
Ratio Tolerance Range (before alarm)	+/- 5%	
Maximum Flow Rate (measured with oil)	3 gallons per minute	13.6 liters per minute
Fluid Viscosity Range	Handles mastic materials which are loaded into heated tanks with ram-fed priming piston pumps	
Air Inlet	1 in. npt(f)	
Fluid Inlets	Pail (Feed Pumps)	
Maximum Fluid Working Pressure for A and B Materials	6000 psi	41 MPa, 414 bar
Maximum Fluid Working Pressure for Flushing Fluid	4500 psi	31 MPa, 310 bar
Maximum Fluid Working Pressure for Heating Fluid	100 psi	0.7 MPa, 7 bar
Maximum Fluid Temperature	160°F	70°C
System Inlet Supplied Air Pressure Range	80-150 psi	0.5-1.0 MPa, 5.5-10.3 bar
Maximum Main Pump Air Pressure	100 psi	0.7 MPa, 7 bar
Maximum Feed Pump Air Pressure	65 psi	0.45 MPa, 4.5 bar
Maximum Tank Air Pressure	90 psi	0.6 MPa, 6 bar
Air Filtration	40 micron main filter, 5 micron control air filter, 3 micron purge controller filter (Hazardous Location only)	
Ambient Operating Temperature Range	32 to 130 °F	0 to 54 °C
Ambient Storage Temperature Range	30 to 160 °F	-1 to 71 °C
Environmental Conditions Rating	Altitude up to 13,123 ft	Altitude up to 4000 m
System Weight (empty, no fluid)	2175 lb	987 kg
Air Filtration	40 micron main filter, 5 micron control air filter, 3 micron purge controller filter (Hazardous Location only)	
Mix Ratio Range		
262869, 262943	1.5:1 to 4:1	
24W626, 262945	1:1 to 1.5:1	
Air Consumption		
Minimum	100 scfm	2.8 meter ³ /min
Maximum	250 scfm	7.1 meter ³ /min
Typical Application	125-175 scfm	3.5-5.0 meter ³ /min
Power Requirements		
Voltage (can be set with jumpers)	Option 1: 200-240 VAC, 3 phase DELTA (3 wire plus ground) Option 2: 350-415 VAC, 3 phase WYE (4 wire including neutral plus ground)	
Wattage	18,800 watts (non-hazardous location) 18,900 watts (hazardous location) 22,900 watts (with hazardous location flush water heater) 23,400 watts (with optional non-hazardous flush water heater)	
Amps	200-240 VAC, 3-phase models DELTA: 63 Amps per phase full load 350-415 VAC, 3-phase models WYE: 40 Amps per phase full load	

XM PFP		
	US	Metric
Wetted Parts		
Suction Tube (Flush)	Aluminum	
Tanks	Stainless Steel	
Flush Pump	Carbide, PTFE, stainless steel, UHMWPE	
Hoses	Nylon	
A and B Metering and Feed Pumps	Carbon steel, alloy steel, stainless steel, zinc and nickel plating, ductile iron, tungsten carbide, PTFE	
Dosing Valves	Carbon Steel, nickel plating, carbide, polyethylene, leather	
Manifold	Carbon steel, nickel plating, carbide, stainless steel, PTFE, UHMWPE	
Mixer	Stainless steel housing with stainless elements	
Purge Requirements (For hazardous models only. Purge air is filtered to instrumentation quality by filters listed above.)		
Minimum Purge Time	3 minutes	
Minimum Purge Flow	4.8 scfm	
Maximum Air Temperature	104°F	40°C
Noise (dBa)		
Sound Pressure *		
	92.2 dBA at 100 psi	92.2 dBA at 0.7 MPa, 7 bar
	85.8 dBA at 70 psi	85.8 dBA at 0.48 MPa, 4.8 bar
Sound Power **		
	103.2 dBA at 100 psi	103.2 dBA at 0.7 MPa, 7 bar
	96.8 dBA at 70 psi	96.8 dBA at 0.48 MPa, 4.8 bar
* Sound pressure measured 3.3 feet (1 meter) from equipment.		
** Sound power measured per ISO-9614-2.		

California Proposition 65

CALIFORNIA RESIDENTS

 **WARNING:** Cancer and reproductive harm – www.P65warnings.ca.gov.

Graco Standard Warranty

Graco warrants all equipment referenced in this document which is manufactured by Graco and bearing its name to be free from defects in material and workmanship on the date of sale to the original purchaser for use. With the exception of any special, extended, or limited warranty published by Graco, Graco will, for a period of twelve months from the date of sale, repair or replace any part of the equipment determined by Graco to be defective. This warranty applies only when the equipment is installed, operated and maintained in accordance with Graco's written recommendations.

This warranty does not cover, and Graco shall not be liable for general wear and tear, or any malfunction, damage or wear caused by faulty installation, misapplication, abrasion, corrosion, inadequate or improper maintenance, negligence, accident, tampering, or substitution of non-Graco component parts. Nor shall Graco be liable for malfunction, damage or wear caused by the incompatibility of Graco equipment with structures, accessories, equipment or materials not supplied by Graco, or the improper design, manufacture, installation, operation or maintenance of structures, accessories, equipment or materials not supplied by Graco.

This warranty is conditioned upon the prepaid return of the equipment claimed to be defective to an authorized Graco distributor for verification of the claimed defect. If the claimed defect is verified, Graco will repair or replace free of charge any defective parts. The equipment will be returned to the original purchaser transportation prepaid. If inspection of the equipment does not disclose any defect in material or workmanship, repairs will be made at a reasonable charge, which charges may include the costs of parts, labor, and transportation.

THIS WARRANTY IS EXCLUSIVE, AND IS IN LIEU OF ANY OTHER WARRANTIES, EXPRESS OR IMPLIED, INCLUDING BUT NOT LIMITED TO WARRANTY OF MERCHANTABILITY OR WARRANTY OF FITNESS FOR A PARTICULAR PURPOSE.

Graco's sole obligation and buyer's sole remedy for any breach of warranty shall be as set forth above. The buyer agrees that no other remedy (including, but not limited to, incidental or consequential damages for lost profits, lost sales, injury to person or property, or any other incidental or consequential loss) shall be available. Any action for breach of warranty must be brought within two (2) years of the date of sale.

GRACO MAKES NO WARRANTY, AND DISCLAIMS ALL IMPLIED WARRANTIES OF MERCHANTABILITY AND FITNESS FOR A PARTICULAR PURPOSE, IN CONNECTION WITH ACCESSORIES, EQUIPMENT, MATERIALS OR COMPONENTS SOLD BUT NOT MANUFACTURED BY GRACO. These items sold, but not manufactured by Graco (such as electric motors, switches, hose, etc.), are subject to the warranty, if any, of their manufacturer. Graco will provide purchaser with reasonable assistance in making any claim for breach of these warranties.

In no event will Graco be liable for indirect, incidental, special or consequential damages resulting from Graco supplying equipment hereunder, or the furnishing, performance, or use of any products or other goods sold hereto, whether due to a breach of contract, breach of warranty, the negligence of Graco, or otherwise.

FOR GRACO CANADA CUSTOMERS

The Parties acknowledge that they have required that the present document, as well as all documents, notices and legal proceedings entered into, given or instituted pursuant hereto or relating directly or indirectly hereto, be drawn up in English. Les parties reconnaissent avoir convenu que la rédaction du présente document sera en Anglais, ainsi que tous documents, avis et procédures judiciaires exécutés, donnés ou intentés, à la suite de ou en rapport, directement ou indirectement, avec les procédures concernées.

Graco Information

For the latest information about Graco products, visit www.graco.com.

For patent information, see www.graco.com/patents.

TO PLACE AN ORDER, contact your Graco distributor or call to identify the nearest distributor.

Phone: 612-623-6921 or Toll Free: 1-800-328-0211 Fax: 612-378-3505

*All written and visual data contained in this document reflects the latest product information available at the time of publication.
Graco reserves the right to make changes at any time without notice.*

Original instructions. This manual contains English. MM 3A2989

Graco Headquarters: Minneapolis

International Offices: Belgium, China, Japan, Korea

**GRACO INC. AND SUBSIDIARIES • P.O. BOX 1441 • MINNEAPOLIS MN 55440-1441 • USA
Copyright 2020, Graco Inc. All Graco manufacturing locations are registered to ISO 9001.**

www.graco.com
Revision Z, June 2020