



READ AND KEEP FOR REFERENCE.

INSTRUCTIONS

*First choice when
quality counts.™*

Standard Lever Pump

Model 114829

For transferring petroleum-based and synthetic oils, antifreeze, and non-corrosive chemicals

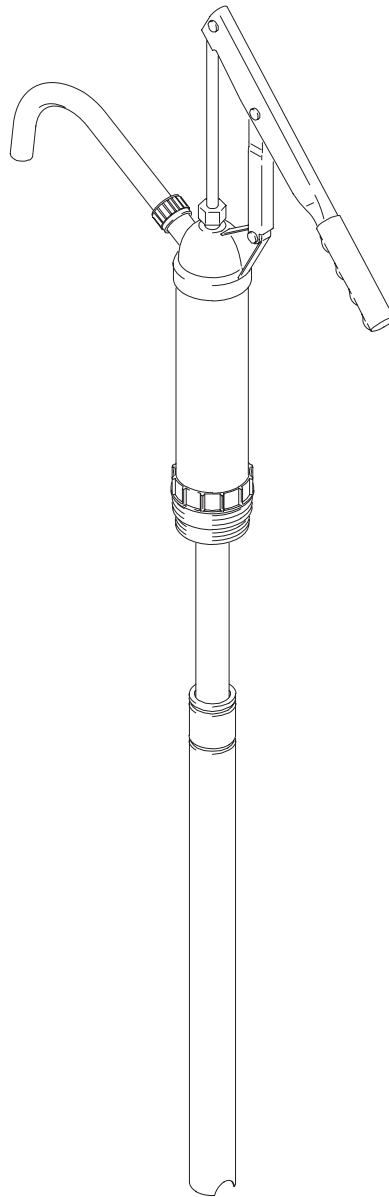

8567A

GRACO INC. P.O. BOX 1441 MINNEAPOLIS, MN 55440-1441

©COPYRIGHT 1998, GRACO INC.

Graco Inc. is registered to I.S. EN ISO 9001

Installation

1. Install the spout gasket (1c) and spout (1a) on the fluid outlet of the pump cylinder (2a). Orient the spout to point down, and tighten the spout collar (1b).
2. Thread the suction tube assembly (3) into the base of the pump cylinder (2a). Tighten it securely with a pipe wrench to prevent air leaks.

NOTE: To prevent damage to the pump assembly inlet or the suction tube, do not use unnecessary force to tighten the suction tube assembly.

3. Extend the telescoping suction tube assembly (3), lower it through the bung opening on the drum, and thread the pump cylinder (2a) into the bung threads.

NOTE: The suction tube assembly (3) adjusts to the proper height for 16-gal (60 liter) and 55-gal (205 liter) drums.

See the **Operation** section for operation instructions.

Operation

Starting the Pump

Start the pump with several quick strokes of the pump handle (2c). If the pump fails to prime within three to five strokes, tighten the suction tube (3) connection to the pump cylinder (2a).

If There is No Fluid Flow

If there is no fluid flow, or if fluid comes out with air, remove the pump from the drum bung, and increase the torque where the suction tube assembly (3) threads into the base of the pump cylinder (2a).

If there is no fluid flow at all, remove the pump from the drum bung, and make sure the suction tube assembly (3) is extended far enough to reach the bottom of the drum.

Compression Bushing Adjustment

If the pump leaks air at the piston rod (2b), tighten the compression bushing (2d).

When Not in Use

Leave the pump handle (2c) up so that the piston is down when the pump is not in use.

Parts

Ref. No.	Description
1	Spout assembly (contains 1a to 1c)
1a	.Spout
1b	.Spout collar
1c	.Spout gasket
2	Pump assembly (contains 2a to 2d)
2a	.Pump cylinder
2b	.Piston rod
2c	.Pump handle
2d	.Compression bushing
3	Suction tube assembly

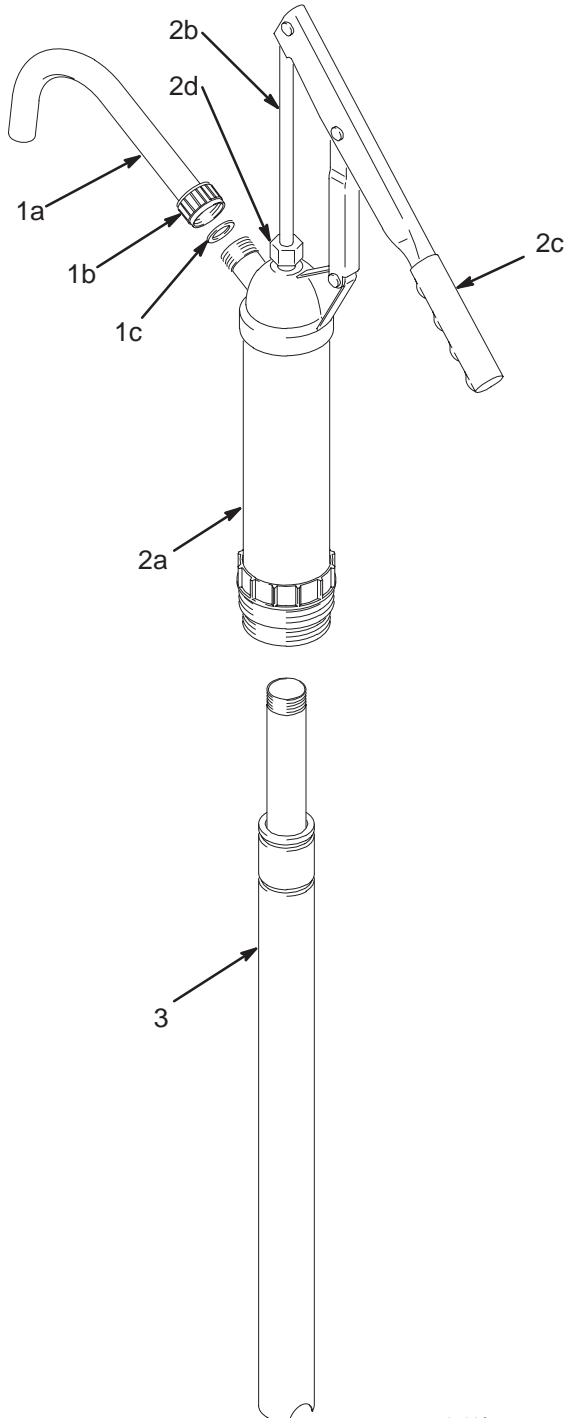

Technical Data

Delivery per down stroke 0.1 gal (0.38 liter)

Wetted parts
 Piston, cylinder housing aluminum
 Piston rod, pump cylinder carbon steel
 Piston rings brass
 Seals buna-N

Bung bushing size 2 in.
 (for standard bung openings)

Inlet tube length telescoping, adjustable
 for 16-gal (60 liter) drums
 or 55-gal (205 liter) drums

Graco Standard Warranty

Graco warrants all equipment manufactured by Graco and bearing its name to be free from defects in material and workmanship on the date of sale by an authorized Graco distributor to the original purchaser for use. With the exception of any special, extended, or limited warranty published by Graco, Graco will, for a period of twelve months from the date of sale, repair or replace any part of the equipment determined by Graco to be defective. This warranty applies only when the equipment is installed, operated and maintained in accordance with Graco's written recommendations.

This warranty does not cover, and Graco shall not be liable for general wear and tear, or any malfunction, damage or wear caused by faulty installation, misapplication, abrasion, corrosion, inadequate or improper maintenance, negligence, accident, tampering, or substitution of non-Graco component parts. Nor shall Graco be liable for malfunction, damage or wear caused by the incompatibility of Graco equipment with structures, accessories, equipment or materials not supplied by Graco, or the improper design, manufacture, installation, operation or maintenance of structures, accessories, equipment or materials not supplied by Graco.

This warranty is conditioned upon the prepaid return of the equipment claimed to be defective to an authorized Graco distributor for verification of the claimed defect. If the claimed defect is verified, Graco will repair or replace free of charge any defective parts. The equipment will be returned to the original purchaser transportation prepaid. If inspection of the equipment does not disclose any defect in material or workmanship, repairs will be made at a reasonable charge, which charges may include the costs of parts, labor, and transportation.

THIS WARRANTY IS EXCLUSIVE, AND IS IN LIEU OF ANY OTHER WARRANTIES, EXPRESS OR IMPLIED, INCLUDING BUT NOT LIMITED TO WARRANTY OF MERCHANTABILITY OR WARRANTY OF FITNESS FOR A PARTICULAR PURPOSE.

Graco's sole obligation and buyer's sole remedy for any breach of warranty shall be as set forth above. The buyer agrees that no other remedy (including, but not limited to, incidental or consequential damages for lost profits, lost sales, injury to person or property, or any other incidental or consequential loss) shall be available. Any action for breach of warranty must be brought within two (2) years of the date of sale.

Graco makes no warranty, and disclaims all implied warranties of merchantability and fitness for a particular purpose in connection with accessories, equipment, materials or components sold but not manufactured by Graco. These items sold, but not manufactured by Graco (such as electric motors, switches, hose, etc.), are subject to the warranty, if any, of their manufacturer. Graco will provide purchaser with reasonable assistance in making any claim for breach of these warranties.

In no event will Graco be liable for indirect, incidental, special or consequential damages resulting from Graco supplying equipment hereunder, or the furnishing, performance, or use of any products or other goods sold hereto, whether due to a breach of contract, breach of warranty, the negligence of Graco, or otherwise.

FOR GRACO CANADA CUSTOMERS

The parties acknowledge that they have required that the present document, as well as all documents, notices and legal proceedings entered into, given or instituted pursuant hereto or relating directly or indirectly hereto, be drawn up in English. Les parties reconnaissent avoir convenu que la rédaction du présente document sera en Anglais, ainsi que tous documents, avis et procédures judiciaires exécutés, donnés ou intentés à la suite de ou en rapport, directement ou indirectement, avec les procédures concernées.

Graco Phone Number

TO PLACE AN ORDER, contact your Graco distributor, or call this number to identify the distributor closest to you:
1-800-367-4023 Toll Free

*All written and visual data contained in this document reflects the latest product information available at the time of publication.
Graco reserves the right to make changes at any time without notice.*

Sales Offices: Minneapolis, Detroit

Foreign Offices: Belgium, England, Korea, France, Germany, Hong Kong, Japan

GRACO INC. P.O. BOX 1441 MINNEAPOLIS, MN 55440-1441

<http://www.graco.com>

PRINTED IN USA 308896 October 1998